

LONG-TERM FEMTOSECOND STABLE RF SIGNAL GENERATION FROM OPTICAL PULSE TRAINS

M. Felber^{#1}, V. Arsov², M. Bock¹, P. Gessler¹, K. Hacker¹, F. Loehl³, F. Ludwig¹, K. Matthiesen¹, H. Schlarb¹, B. Schmidt¹, S. Schulz⁴, A. Winter⁵, L. Wissmann⁴, J. Zemella⁴

¹ *Deutsches Elektronen Synchrotron - DESY, Hamburg, Germany*

² *Paul Scherrer Institut - PSI, Villingen, Schweiz*

³ *Cornell University, New York, USA*

⁴ *Universität Hamburg, Hamburg, Germany*

⁵ *ITER, Cadarache, France*

Abstract

Next generation FEL light sources like the European XFEL require timing stability of 10-20 fs between different subsystems. In optical synchronization systems, the timing information is distributed across the facilities via sub-ps laser pulses travelling on length stabilized optical fibers. Several methods are available for RF extraction from the pulse train. In this paper, we characterize the long-term phase stability of a 1.3 GHz signal produced from the direct conversion of a higher harmonic of the pulse repetition frequency and from a voltage controlled oscillator locked with a PLL that uses a Sagnac-Loop as balanced optical-microwave phase detector.

INTRODUCTION

Optical synchronization systems are becoming an extension of the coaxial cable based radio frequency (RF) timing distribution in modern FEL facilities because they have shown to be capable of providing a point to point stability on a 10 fs level. At DESY, such a system is under development for the XFEL and is currently being commissioned and tested at FLASH.

The Master Laser Oscillator (MLO), a mode-locked, erbium-doped fiber laser, generates a train of sub-100 fs pulses with a precise repetition rate containing very low high frequency jitter. It is locked to the RF Master Oscillator (MO) in order to prevent any low frequency drift between MLO and MO. The pulses are distributed via length stabilized optical fibers to various locations – up to 15 will be installed at FLASH. The distribution unit and the length stabilization setups for each fiber link are located next to the MLO to avoid timing drift in this part of the system. The length stabilization of the fiber link uses balanced optical cross-correlation for comparing, with sub-femtosecond resolution, a pulse that traveled along the fiber link and back with a reference pulse from the MLO. A motorized delay line is used for coarse adjustments and a piezo based fiber stretcher compensates for fast fluctuations.

At the end station of each link, the timing information can be used for one of three applications.

(1) Optical-to-optical synchronization: Synchronization of other lasers, e.g. photo-injector laser, seed laser, or probe laser. Using the balanced cross-correlator with different wavelengths for locking a mode-locked laser to the pulse train overcomes the jitter and drift limitations of a conventionally synchronized laser using RF mixers and amplifiers [1,2].

(2) Diagnostic purposes: E.g. high precision, large aperture beam position monitoring or sub 10 fs electron bunch arrival time measurements [3]. These diagnostic signals can be used to set up a feedback system for regulating the RF of the accelerator, thereby stabilizing the electron beam and FEL pulses. At FLASH, first results of an arrival time feedback look very promising.

(3) Laser-to-RF conversion (L2RF): An ultra-stable microwave signal must be generated from the optical pulse train to provide a reference for the pulsed klystrons, and for Low Level RF applications like cavity field detection and regulation. L2RF is a key component for building a stable machine, since disturbances in this part remain as residual jitter, thus they directly impact the stability of the accelerated beam. The two methods of direct conversion and Sagnac-Loop PLL have been investigated before [4,5,7]. In this paper, we demonstrate unprecedented drift performance of both schemes in generating 1.3 GHz, the main driving RF for the accelerators FLASH and XFEL.

DIRECT CONVERSION

The direct conversion [5] is the simplest and therefore the cheapest and most robust method, in terms of component failure. The laser pulses are fed to a large bandwidth (10 GHz) photodiode, generating an electrical pulse train with frequency components at all harmonics of the pulse repetition rate - up to the diode's cut-off frequency. One of these harmonics is filtered out using a bandpass filter and is usually further amplified, e.g. at FLASH the 1.3 GHz main RF is the 6th harmonic of the ~216 MHz repetition rate of the laser pulses. The advantages mentioned above come with the price of several possible error sources. That is, since the extracted RF signal is not locked to the source, timing drifts and

[#]Matthias.Felber@desy.de

jitter of the conversion chain remain uncompensated. The noise floor of the extracted signal is limited by shot noise, and intensity noise of the laser power converts to phase noise due to amplitude-to-phase conversion [6].

For the XFEL, it was decided to use 200 MHz repetition rate laser pulses and therefore it is not possible to directly extract 1.3 GHz. A gating unit that selects every second pulse cuts down the pulse train to 100 MHz, so the 13th harmonic must be extracted. The performance of this gating has yet to be investigated.

SAGNAC-LOOP PLL

Operating Principle

To overcome the limits of the direct conversion, a more sophisticated scheme is used to lock a local oscillator, i.e. a Dielectric Resonator (DRO), to the laser repetition rate with a PLL. Therefore a low drift optical-RF phase detector is needed. It is realized by means of an asymmetrically biased Sagnac-Loop interferometer, providing a balanced detector scheme. The phase information is encoded in the amplitude modulation of the laser pulses at half the repetition rate. This is detected and used to tune the DRO. A detailed description of the operating principle can be found in [4].

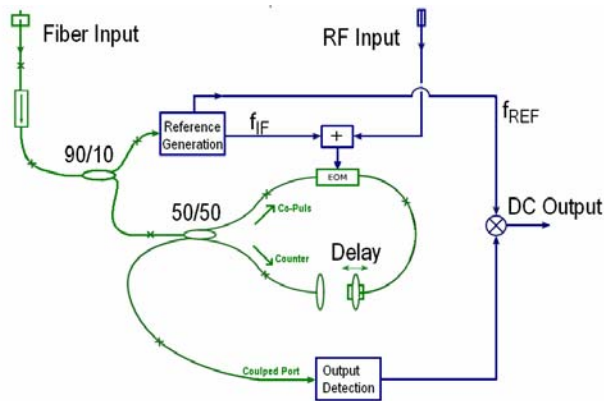

Figure 1: Sagnac-Loop interferometer as optical-RF phase detector. Green: Optical part, Blue: RF part

Design Considerations

Compared to most previous investigations which used DROs at ~10 GHz [7], we face two major drawbacks when using 1.3 GHz.

First, the phase detector's sensitivity, expressed as the phase to voltage conversion factor $K\phi$ depends on the steepness of the RF zero crossing. Hence, 1.3 GHz gives almost a factor of 8 smaller error signals for the feedback controller.

Second, the counter-propagating pulse in the loop cannot be neglected when using a 1.3 GHz DRO because the modulation depth in the Electro-Optic Modulator (EOM) of this pulse is only about 6dB lower than that of the co-propagating pulse. Thus the relative distance between co- and counter pulses at the location of the

EOM in the loop becomes a critical parameter. Figure 1 shows how this impacts the layout: a free-space section must be inserted into the loop, allowing for precise length adjustment. To increase the sensitivity of the phase detector, the co- and counter propagating pulses that hit the zero crossing of the 1.3 GHz at the EOM must experience opposite slopes of the RF. This also means that they cannot be biased in the extremes of the sinusoidal intermediate frequency f_{IF} , making the biasing somewhat susceptible to phase jitter of f_{IF} .

Since the laser repetition rate f_{REP} is 216 MHz, the amplitude modulation is at 108 MHz. The reference frequency f_{REF} (108 MHz), used to mix the modulation down to baseband, is generated by tapping 10% of the incoming light, putting it on a photodiode and dividing the resulting 216 MHz by two. The intermediate frequency was decided to be 325 MHz and is also extracted from the divider output since it contains some harmonics due to the square wave character.

MEASUREMENT SETUPS

Two different setups, both built as prototypes on breadboards, were investigated:

(1) One Sagnac-Loop PLL was used to lock a DRO to the laser repetition rate, and the second Sagnac-Loop was used as phase detector to determine the residual timing drift.

(2) A Sagnac-Loop PLL was used to lock a DRO to the laser repetition rate, and a direct conversion setup was extracting 1.3 GHz from the pulse train. Both RF signals were compared by a commercial phase detector.

MEASUREMENT RESULTS

It turned out to be non-trivial to obtain reproducible long-term low drift signals from the setups. Quite often it was not clear why a certain measurement showed more drift than another one. The results presented here were achieved after excessive optimization of the setups and represent some of many highlights of the recorded data.

With the first measurement setup (two Sagnac-Loops), we achieved 9.6 fs rms over 7 hours.

Figure 2 shows the phase detector output between the direct conversion signal and the locked DRO. The falling curve at the beginning of the plot shows the settling of the system to a stable point due to warming up of electronic components. The increasing deviation at the end of the measurement was caused by a person entering the laboratory which led to a 0.05 deg temperature change at the setup. Leaving out the beginning and the end of the measured data, we achieved a relative timing jitter of 10.7 fs rms over more than 15 hours.

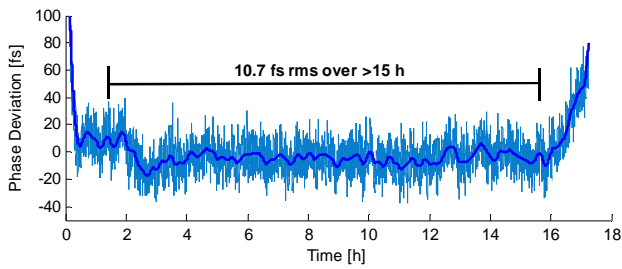

Figure 2: Relative timing drift between direct conversion and DRO output

It is not possible to judge from this measurement which of the both schemes is the limiting one. Also it should be mentioned that the laser intensity fluctuations were very low with an amplitude change of 0.04% over 12 hours.

CONCLUSION AND OUTLOOK

Both methods that are presented here have shown to be capable of fulfilling the requirements of long-term 10 fs stable RF generation.

Since the good performance of the direct conversion depends on low laser power fluctuations, active amplitude stabilization for the pulse train is considered. Together with the gating unit that is needed when going to 200 MHz repetition rate, the direct conversion scheme becomes much more complex and therefore less attractive for the XFEL.

The Sagnac-Loop interferometer still has some room for improvements. Up to now, we used a breadboard setup which will be replaced by a robust metal box providing better shielding from environmental effects like

temperature changes, air convection, and vibrations. Integration of the RF part could reduce its remaining drift.

Besides investigation of the short-term performance, the Sagnac-Loop PLL will be used to lock the MLO to the MO at FLASH. This will be the first-long term test in an accelerator environment.

This work was supported by the European IRUVX Project.

REFERENCES

- [1] T.R.Schibli et al, *Opt. Lett.* 28, 947 (2003)
- [2] S.Schulz et al, "All-Optical Synchronization of Distributed Laser Systems at FLASH" PAC09, (this conference); <http://www.JACoW.org>
- [3] F.Loehl et al, "Experimental Determination of The Timing Stability of the Optical Synchronization System at FLASH" EPAC08, Genoa, Italy
- [4] J.Kim et al, "Balanced Optical-Microwave Phase Detectors for Optoelectronic Phase-Locked Loops" *Opt. Lett.* 31, 3659 (2006)
- [5] B.Lorbeer et al, "Noise and Drift Characterization of Direct Laser to RF Conversion Scheme for the Laser Based Synchronization System for FLASH at DESY" PAC07, Albuquerque, USA
- [6] E.N.Ivanov et al, *IEEE J. Sel. Top. Quantum Electron.* 9, 1059 (2003)
- [7] J.Kim et al, "Drift-free Femtosecond Timing Synchronization of Remote Optical and Microwave Sources" *Nature Photonics* 2, 733 (2008)