

# THE BOUNCER MODULATORS AT DESY

R. Wagner\*, A. Bruesewitz\*, S. Choroba\*, H.-J. Eckoldt\*, F. Eints\*, T. Froelich\*, T. Grevsmuehl\*, J. Hartung\*, A. Hauberg\*, L. Jachmann†, J. Kahl\*, W. Koehler†, H. Leich†, N. Ngada\*, M. Penno†, N. Poggensee\*, I. Sandvoss\*, I. Sokolov\*, V. Vogel\*, R. Wenndorff†

\*DESY, Hamburg, Germany, †DESY, Zeuthen, Germany

**Keywords:** Free electron laser, superconducting RF, modulator, klystron, RF system

## Abstract

The FLASH linac at DESY in Hamburg is a superconducting linear accelerator which provides an electron beam to generate laser light in the nm-regime. Five RF stations provide RF power up to 10MW to generate and accelerate an electron beam up to 1GeV in an RF gun and forty-eight superconducting nine-cell cavities, respectively. Several bouncer type modulators produce HV-pulses up to 130kV, 140A at 1.5ms and up to 10Hz for the 1.3GHz klystrons and multi-beam klystrons of the linac. The first modulators have been constructed and delivered several years ago by FNAL to the TESLA Test Facility at DESY, which is now the FLASH linac. Later additional modulators have been assembled at DESY from subsystems, which have been constructed and manufactured by industrial companies. Two additional systems are in operation at PITZ at DESY in Zeuthen. This paper reports on the layout of the modulators, the major changes and improvements and the operation experience.

## 1 Introduction

The FLASH (Free Electron LASer at Hamburg) Free Electron Laser at DESY provides radiation in the VUV-regime for scientific applications in the field of physics, biology, chemistry or material sciences [1, 2]. At present radiation down to 6.5nm has been produced. A 1GeV electron beam is used to generate VUV-radiation in several wiggler magnets, which are located at the end of a superconducting linear accelerator. The electrons are produced in a one-and-half cell normal conducting 1.3GHz RF gun by a cathode which is located at the point of maximum electrical RF field inside the gun cavity. When a laser fires onto the cathode electrons are generated and accelerated in the electrical field of 46MV/m. The electron beam is then accelerated in forty-eight superconducting niobium nine-cell cavities, which are operated at 1.3GHz too, to 1GeV. The cavities are grouped into six accelerating modules of eight cavities each. The beam pulse duration is 800 $\mu$ s with a repetition rate of typical 5Hz. Within each of these macro-pulses 800 electrons bunches with a separation of 1 $\mu$ s can be accelerated.

PITZ (Photo Injector Test stand in Zeuthen) at DESY in Zeuthen is a dedicated test facility which allows to test and investigate the physics of RF electron guns [3]. Two RF stations are operated under similar conditions as the stations

for the RF gun for FLASH in Hamburg. The repetition rate is 10Hz.

In order to provide RF power at 1.3GHz for the superconducting cavities and the normal conducting cavity of the RF gun respectively, several high power RF stations are in operation. Each of these RF stations consists of a number of subsystems like klystron, HV pulse modulator, RF waveguide distribution and other subsystems. The klystrons are single beam klystrons which are operated up to 5MW (THALES TH2104C) or a multi-beam klystron (THALES TH1801) which is operated up to 10MW at pulse durations of 800 $\mu$ s or 1.3ms. The RF pulse duration takes into account the filling time of the normal conducting cavity of the gun of some microseconds and of the superconducting cavities of 500 $\mu$ s. Besides the RF gun which requires 5MW at 800 $\mu$ s, all the superconducting cavities are operated at input power levels of 50kW to 350kW at 1.3ms pulse duration. This allows operation of the cavities at an accelerating gradient beyond 30MV/m. The RF power produced by the klystrons is distributed to the cavities by a waveguide distribution system of WR650 standard. Figure 1 shows the basic layout of FLASH RF system. Four RF stations plus one spare RF station provide RF power for the RF gun and the superconducting cavities.

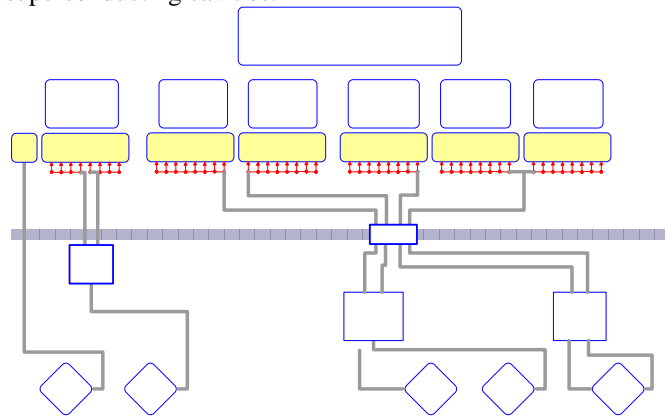

Figure 1: FLASH RF System Overview

The HV modulators together with pulse transformers provide the HV pulses which are required by the klystrons. They convert AC line power to pulsed power in rectangular shaped pulses at the 120kV level.

## 2 Modulator Requirements

The following table summarizes the modulator operation parameter when operated with a 5MW klystron or a 10MW multi-beam klystron. The shorter pulse duration refers to the operation of the klystron as power source for an RF gun. The typical repetition rate at FLASH is 5Hz and 10Hz at PITZ. It is foreseen to operate the RF stations at FLASH at 10Hz in the future, too.

	Typ. 5MW Klystron	Typ. 10MW MBK	Max.
Pulse Voltage /kV	128	117	130
Pulse Current / A	89	135	140
High Voltage Pulse duration /ms	1.5	1.0-1.5	1.7
High Voltage Rise and Fall Time (0-99%) / ms	0.15	0.2	0.2
High Voltage Flat Top (99%-99%) / ms	1.3	0.8-1.3	1.5
Pulse Flatness / %	< ±0.3	< ±0.3	< ±0.5
Pulse-to-Pulse Voltage fluctuation / %	< ±0.2	< ±0.2	< ±0.5
Pulse Repetition Rate / Hz	5	5	10

Table 1: Modulator operation parameter

## 3 The Bouncer Modulator

In order to produce the 1.5ms long HV pulses a bouncer modulator consisting of a DC high voltage power supply, a pulse generating unit and a pulse transformer has been selected in the early 1990s. Today other modulator types might be developed and might have certain advantages, but at that time the bouncer modulator seemed to be the best solution in terms of performance, reliability and cost [4].

Figure 2 shows the basic circuit diagram of the modulator.

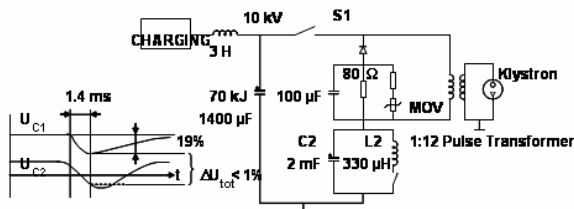

Figure 2: Bouncer modulator circuit diagram

A DC power supply charges the main capacitor bank of 1.4mF to the 10kV level. By closing the main switch S1 a current starts to flow via the 1:12 pulse transformer into the

klystron. The pulse is terminated after 1.5ms (1.3ms flat top plus ~0.2ms rise time) by turning off the current through the main switch of up to 1.6kA.

Since the main capacitor bank discharges during the pulse, a slope of approximately 20% would be obtained on the HV flat top. In order to avoid a main capacitor bank of 29mF, which would allow for a pulse flatness of ±0.5% but at the same time increase the stored energy by a factor of twenty, an oscillating circuit, the bouncer, is installed. By triggering this resonant LC circuit before the main switch is triggered a 5m long single sine wave with at the 1kV level is produced. The linear part of this oscillation compensates the drop down to ±0.5% level.

A 1:12 pulse transformer transforms the 10kV level to the 120kV level. In order to disturb the pulse shape as less as possible the leakage inductance of the transformer must be as low as possible. The transformers have leakage inductances of less than 200µH and 350µH. The transformers are 3.5m long, 1.2m wide and 1.4m high. The klystrons are installed on top of the transformers with the klystron guns immersed in a separate transformer tank compartment filled with transformer oil. The size of the modulator unit containing the 10kV pulse generating unit and the HV power supply is 5m long times 2m high times 2m wide.

## 4 Bouncer Modulator Types

Bouncer modulators have been conceived for FLASH by FNAL, Batavia, Illinois. In the beginning of the 1990s FLASH was constructed as the TESLA Test Facility (TTF), a facility to develop and test all components required to build a superconducting linear collider at 500GeV<sub>cm</sub>. Within the TESLA collaboration FNAL developed, manufactured and delivered three bouncer modulators to DESY. These modulators are still in use, one for the test of superconducting cavities and two for FLASH. The following modulators have been constructed based on the same bouncer principle. Main components, like pulse generating units, the DC power supplies and the pulse transformers have been developed and manufactured by different industrial companies. The modulators have been assembled and commissioned from these components at DESY. In total there are now nine additional modulators made of industrial subsystems in operation, three for FLASH, two for PITZ and four for XFEL test stands.

## 5 FNAL Modulators

Three modulators have been built at FNAL [5, 6, 7, 8]. The first one has been delivered to DESY in 1993. It was designed to drive a Thomson TH2104C klystron up to 5MW RF output at 2ms pulse duration. The design of the other two modulators (which were built about two years later) was changed to drive a new high efficiency 10MW multi-beam klystron. This klystron required a modulator with higher peak power but with a shorter pulse length of 1.5ms.

	Modulator #1	Modulator #2,3
Pulse Width	2.0 ms	1.5 ms
Output Voltage	130 kV	120 kV
Output Current	95 A	135 A
Repetition Rate	10 Hz	10 Hz

Table 2: Different requirements for the FNAL Modulators



Figure 3: The Bouncer Modulator from FNAL (HV power supply and pulse generating unit in the front, pulse transformer and klystron in the rear)

All modulators use the same circuit topology. The 10kV DC power supply with a thyristor controller at the primary side (400V AC) and an oil-filled transformer charges the capacitor bank. It consists of fifty-six 12kV capacitors of 25  $\mu$ F each, built in aluminium foil technology with paper dielectrics. The HV pulse is created by a semiconductor switch, which connects the capacitor bank to the pulse transformer, manufactured by Stangenes Ind., Palo Alto, USA. The crowbar, which shall protect the klystron in case of arcing and additional failure of the semiconductor main switch, consists of two redundant ignitrons. In order to meet the new output requirements FNAL modulators #2 and #3 make use of different components at certain areas. The ratio of the pulse transformer had been changed from 1:13 to 1:12 and the bouncer choke had been changed from 600  $\mu$ H to 330  $\mu$ H. The most significant change has been made to the high voltage switch. Modulator #1 uses a stack of six GTOs. A GTO (Gate Turn Off thyristor) is a special type of thyristor, which can be turned on and off by a gate signal. The newer modulators #2 and #3 use fifteen IGBTs (Insulated Gate Bipolar Transistors) (Eupec FZ 1200R16KF4). The assembly consists of twelve series IGBTs forming the main switch plus three more IGBTs forming the backup switch for protecting the klystron in case of a main switch breakdown. An IGBT combines the simple gate-drive characteristics of the MOSFETs with the high-current and low saturation-voltage capability of bipolar transistors. It consists of an isolated gate FET for the control input and a bipolar power transistor as a switch. The IGBT has several advantages compared to the

GTO. The insulated gate can be operated with a more simple drive circuit with much lower drive power. The turn on and turn off times are approximately ten times shorter. The modulator is shown in Figure 3.

## 5 Industrial / DESY Modulators

The next modulators have been constructed from subsystems made by industrial companies. The probably most important subsystem, the pulse generating unit, has been constructed by Puls-Plasmatechnik (PPT) in Dortmund, Germany [9, 10]. The energy storage capacitor bank is charged from a 12kV DC power. The capacitor bank consists of three self healing capacitors (0.48 mF each) with a total capacity of about 1.5 mF. An exception is the first unit, manufactured by PPT, which uses twelve smaller capacitors,. The high voltage switch is a water-cooled press stack with seven IGBTs in series (ABB 5SHY35L4503). An IGBT (Integrated Gate Commutated Thyristor) is similar to a GTO but has several improvements. It has much faster turn-off times. The drive circuit is integrated into the package of the device. The first modulator uses two redundant ignitrons as crowbar whereas the later modulators make use of a semiconductor switch made by a stack of three light triggered thyristors, LTT (Infineon T2563NH). Few meters long HV cables connect the pulse generating units and the pulse transformer made by ABB, Bad Honnef, Germany. The 12kV DC charging powers supply, made by FUG, Rosenheim, Germany, or Poynting, Dortmund, Germany, is a constant power supply [11]. Although it recharges the main cap bank with a repetition rate of several Hertz it takes constant power from the main thus avoiding any impact on the mains. Figure 4 shows the HV power supply and the pulse generating unit of one of the new bouncer modulators.



Figure 4: HV power supply and pulse generating unit of one of the new bouncer modulators

## 6 Operation Experience

The modulator #2 and #3 from FNAL are in operation at TTF/FLASH since 1996 and 1998 respectively. With the exception of two main components (HV power supply transformer and pulse transformer) which failed and caused

interruption of FLASH operation for several days, only minor failures occurred, which usually allowed repair within several hours or less. In both modulators some feedthroughs of the HV power supply got leaky and needed to be replaced. The pulse transformers failed several times with a short circuit between the windings of the primary and secondary side or just on the secondary side. After some years of operation the wide side of the basket on which the outer primary winding has been wound bend inwards towards the secondary winding causing short circuits and damage of the windings. The transformers had to be taken apart and repaired either at DESY or with the help of local companies. The manufacturer has been informed and already conceived measures to improve the design. Typical other minor failures have been caused e.g. by broken capacitors of the main bank, due to contact problems of some resistors or by cable connections. The main switches never caused any problem.

The first modulators made by subsystems manufactured by industrial companies are in operation since 2001. At present PPT has manufactured and delivered nine pulse generating units. A similar number of HV power supplies and pulse transformers have been manufactured by Poynting, FUG and ABB. In case of failure of components repair was mostly possible within several hours or less. Main failures have been caused by broken capacitors in the bouncer circuit or by broken components in the LTT crowbar system. The latter problem is still under investigation. Two times a bouncer main coil broke at DESY in Zeuthen and had been replaced by a bouncer coil of different type with better cooling capability and mechanical improvements. It should be pointed out, that also at these modulators we lost no IGCT switch during normal operation. Just at the early experimental stage two switches were damaged due to false triggering.



Figure 5: Typical waveforms of one of the new modulators in use at a klystron test stand (Blue: Klystron Voltage: 117kV, Red: Klystron Current: 135A, Green and Magenta: Klystron RF output power 2 times 5MW)

## 7 Next Steps

During the next FLASH shutdown, which starts at the end of September 2009 the about 13 years old FNAL modulators

including the pulse transformers will be replaced with new modulators using the same type of industrial subsystems as the other remaining systems. One reason is that many spare components for the FNAL modulators are no longer available. The other important reason is that operating FLASH with the same type of modulators allows storing spare components for just one type of modulators, improving maintenance and repair procedures thus improving the entire reliability of the FLASH RF system.

## Acknowledgements

The authors acknowledge the effort of the people at FNAL in order to construct and build bouncer modulators meeting the TTF/FLASH requirements. Without them it would have been difficult if not impossible to supply HV pulses to the klystrons for the TTF at that early stage of the project.

## References

- [1] W. Ackermann et al., "Operation of a free-electron laser from the extreme ultraviolet to the water window", *Nature Photonics* 1, 2007, 336-342
- [2] S. Schreiber, B. Faatz, J. Feldhaus, K. Honkavaara, R. Treusch "FLASH operation as an FEL user facility" PAC 2009 Conference, May 4-8, 2009, Vancouver, Canada
- [3] F. Stephan, C.H. Boulware, M. Krasilnikov, J. Bähr, et. al., "Detailed characterization of electron sources at PITZ yielding first demonstration of European X-ray Free-Electron-Laser beam quality", *submitted to PRST-AB*
- [4] W. Bothe, Pulse Generation for TESLA, a Comparison of Various Methods, TESLA Report 94-21, July 1994.
- [5] The TESLA TEST FACILITY LINAC-Design Report, Ed. D.A. Edwards, Tesla Report 95-01.
- [6] H. Pfeffer, C.Jensen, S. Hays, L.Bartelson, The TESLA Modulator, TESLA Report 93-30.
- [7] H. Pfeffer, L. Bartelson, K. Bourkland, C. Jensen, Q. Kerns, P. Prieto, G. Saewert. D. Wolff, A Long Pulse Modulator for Reduced Size and Cost, Fourth European Particle Accelerator Conference, London 1994.
- [8] H. Pfeffer, L. Bartelson, K. Bourkland, C. Jensen, P. Prieto, G. Saewert. D. Wolff, "A Second Long Pulse Modulator For TESLA Using IGBTs", Proceedings of the Fifth European Particle Accelerator Conference, EPAC96, Sitges (Barcelona), 10-14 June 1996, p. 2585.
- [9] W. Kaesler, "A Long-Pulse Modulator for the TESLA Test Facility (TTF)", Proceedings of the XXII International Linear Accelerator Conference. Linac 2004, Lübeck, Germany, August 16-20, 2004, p 459.
- [10] W. Kaesler, Bouncer Modulator for Flash Facility at DESY, 20<sup>th</sup> Pulsed Power Symposium 2007, 17-19 September 2007, Didcot, UK
- [11] H.-J. Eckoldt, N. Heidbrook, "Constant Power Power Supplies for the TESLA Modulator", TESLA Report 2000-36.