

+

+

# Highly Available Central Services

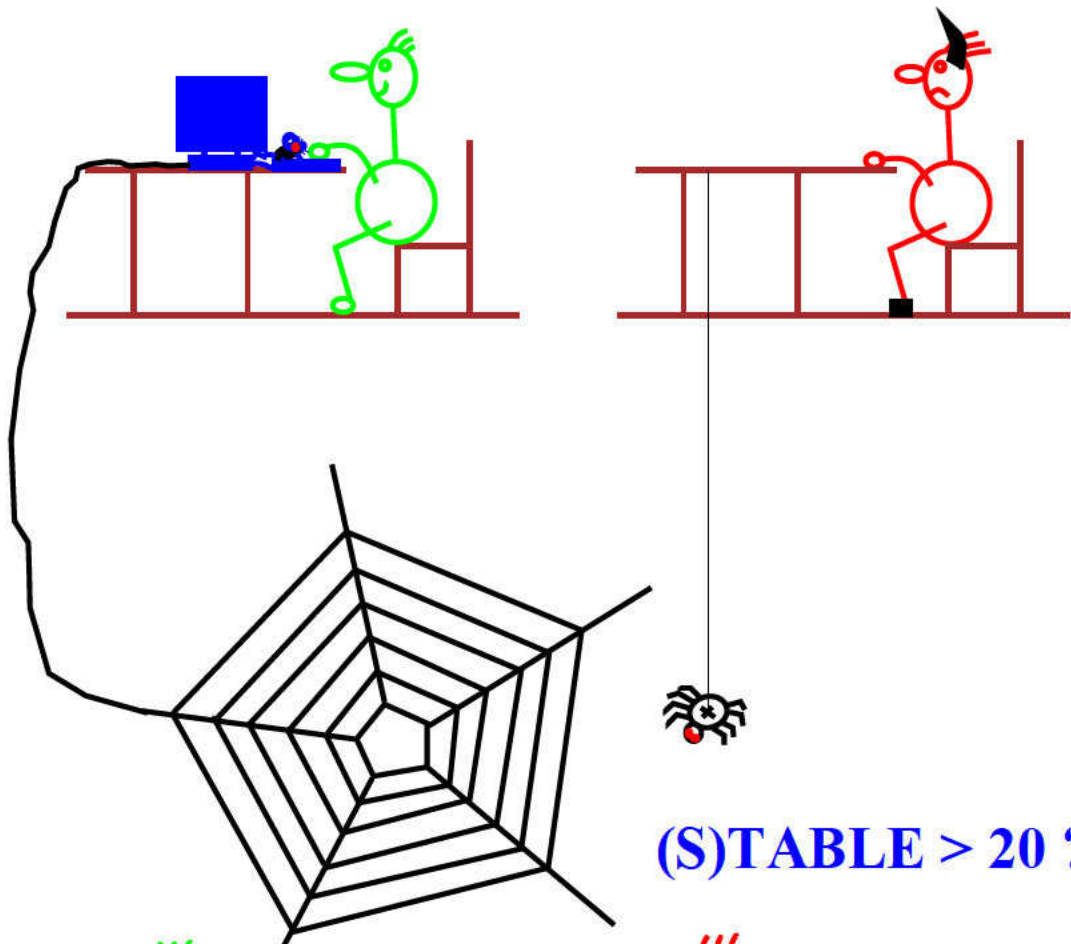

**(S)TABLE > 20 ?**

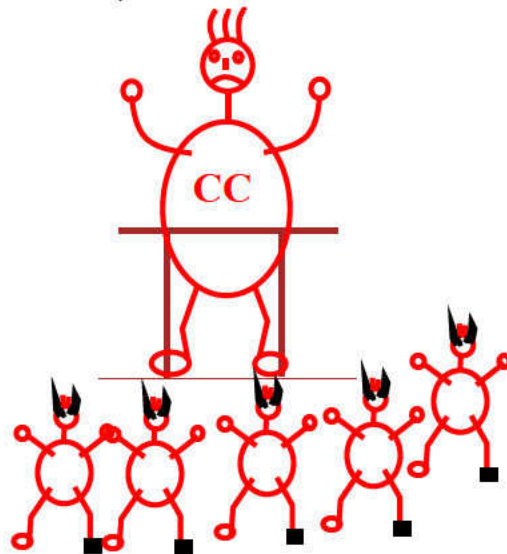
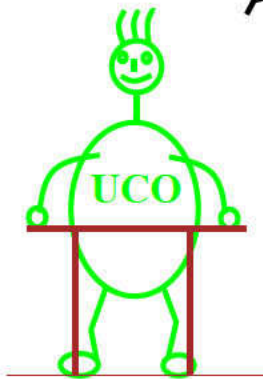

Thomas Finnern  
 DESY, Group ZDV  
 phone: +49 40 8998-2753  
 email: finnern@desy.de

+



# Services:

Service	Examples	Points of Failure / Comments
Network	Ethernet, FDDI, Token Ring, ...	Hardware: Plugs, repeaters / Be careful Usage: Broadcast storm / Be careful
Information	Name service BOOTP	Base service / Redundant by configuration Local broadcast / Redundant by router help
Processing	Multiuser machine	Software crashes / Systems not user resistant
Memory	Multiuser machine	Always too small / Money helps
Disk	Home directories	Always too full / Money or quota needed
Authentication	User registry	YP/NIS/AFS/DCE
Authorization	License	Software e.g. window manager or compiler
File Access	TFTP NFS AFS X11R5-FS	Only limited client count / Avoid it Multi vendor lock problems / Replace by AFS No cloneable r/w volumes / r/o volumes OK Limited client count / Needs observation

+

+

## System Down Times:



System Down Times	Percentage
Maintenance	10 %
Crash	90 %

  

Reasons for Crashes	Percentage
Hardware	10 %
Software	50 %
Human Failures	40 %

- Monitor the systems
- Automate daily jobs
- Automate failure recovery
- Have some spare parts
- Have skilled operators
- Control root access
- Configure/Program with care



# X-Servers:

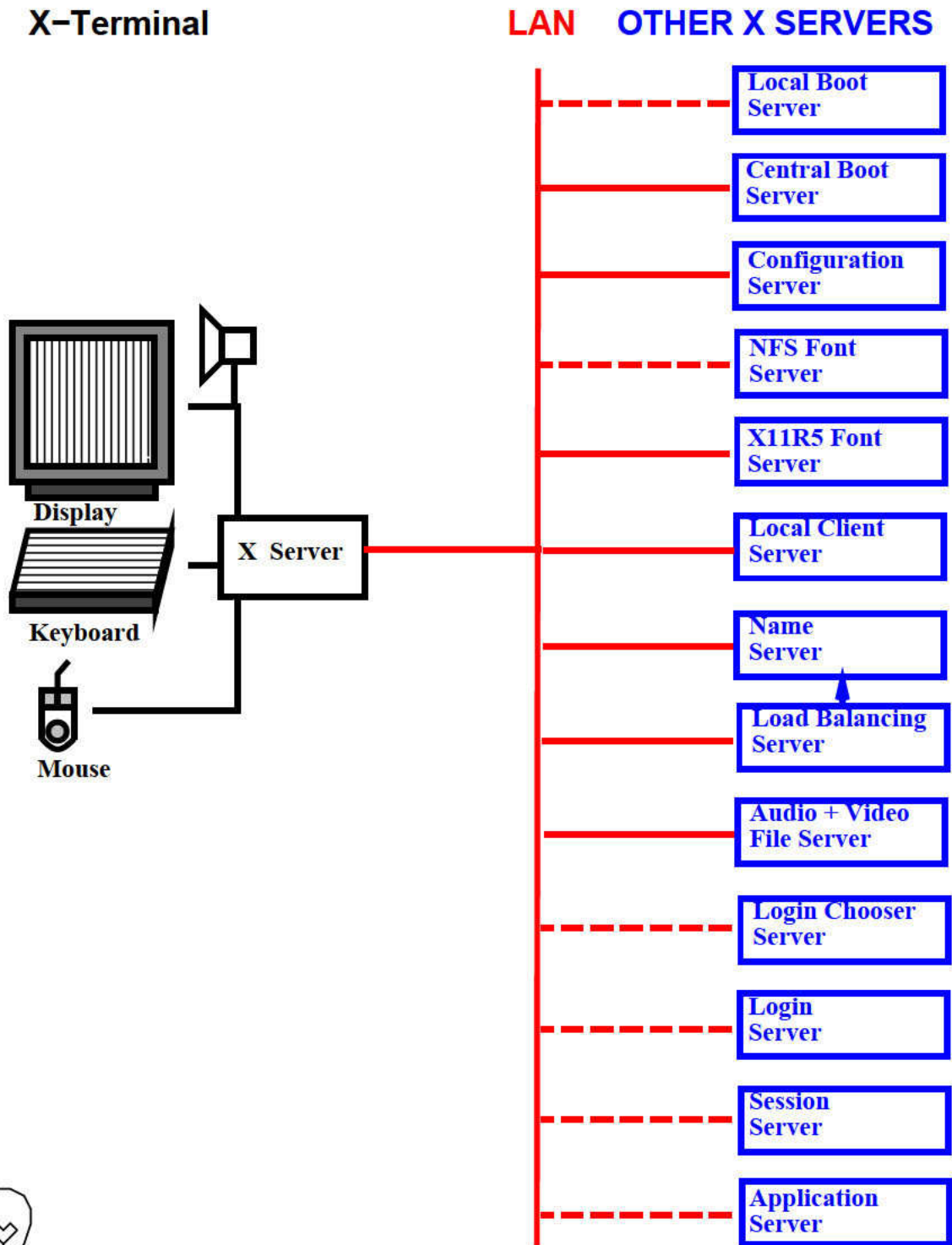

## Info Service:

### • BOOTP

- Started by inetd + srcmstr
- Local broadcast + router support for hale1 + hale2
- No correlation to file service
- Hostname, subnet mask, bootimage, name server(s), gateway(s), (configuration)

### • NAMED

- Caching name server for main domain
- ISS = IBM's Interactive Session Support
- Generic names for hale and wgs

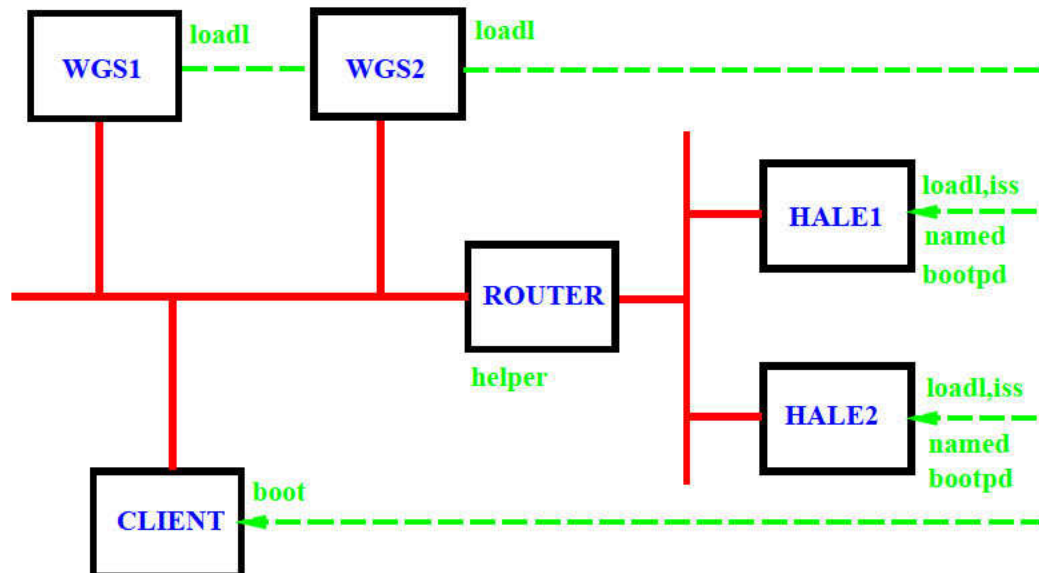

## File Service:

### • TFTP

- Started by inetd + srcmstr
- Critical client count, may corrupt HALE
- Switch to NFS during configuration (Old terminals only server load)
- Replacing boot proms to support full NFS boot

### • NFS

- Started by srcmstr
- Boot and configuration
- Local client service (e.g. wm), long history

### • AFS

- AFS/NFS translation
- Access read only
- Read user files for fonts, audio, video

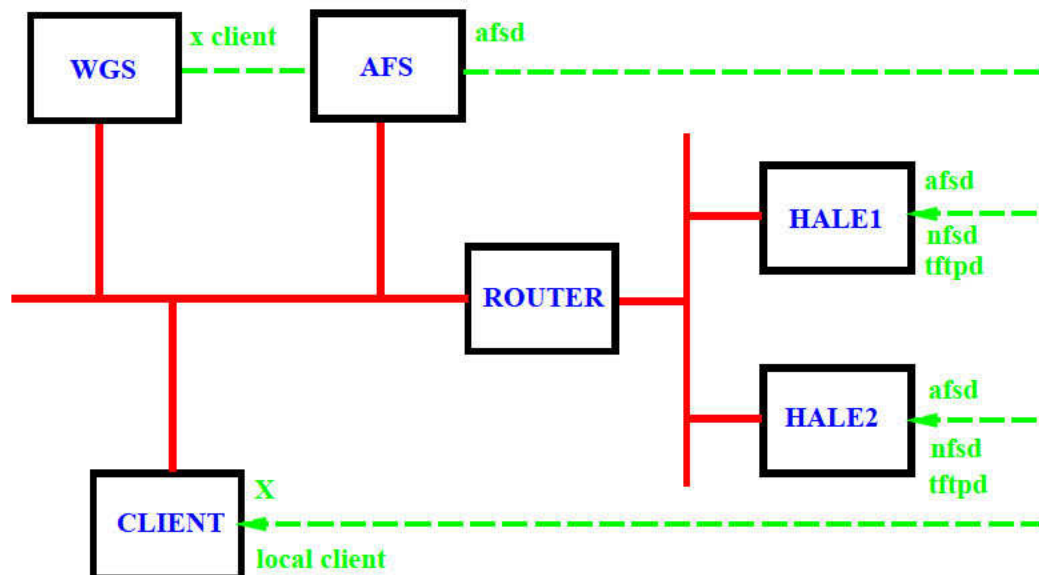



## High Availability:

- Mutual takeover with different tasks
- Non-concurrent shared disk access
- IP-Number swapping on FDDI
- Disks manually mirrored
- NFS uses `/x0/file` or `/x1/file` notation  
with same id's on both machines
- TFTP uses `/file` notation  
with link from `/file` to `/x0/file` or `/x1/file`
- Takeover time about 120 seconds

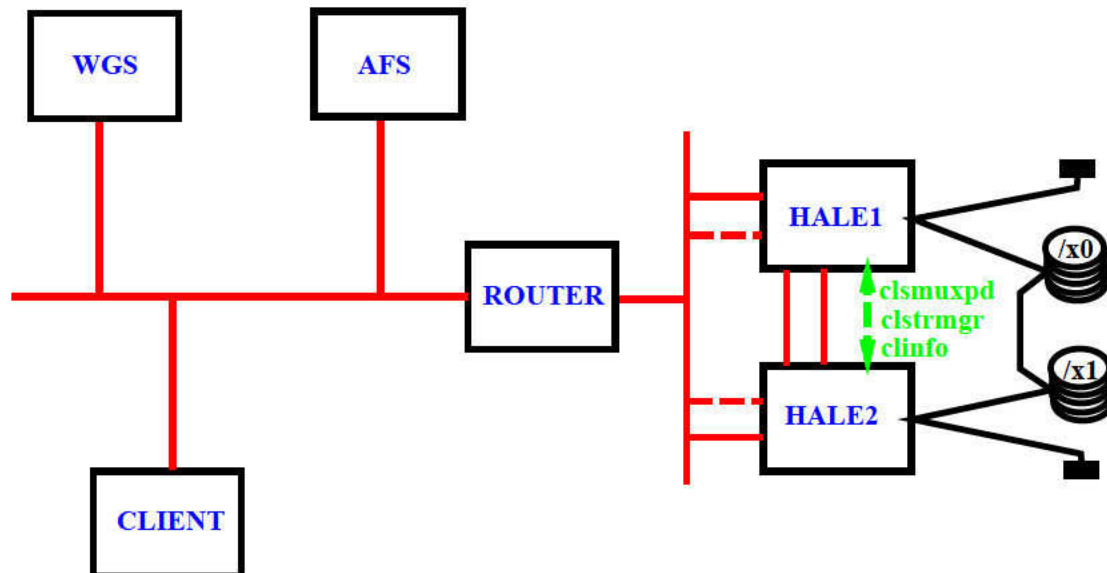

## Status September 95:

### ● Terminals, PC's and Printers

- Ready: NCD and newer TEK terminals with symmetric configurations (210 Terminals are running in production)
- Ready: PCXware support with same configurations as xterminals (Going into production soon)
- Ready: HPNP (70 HP-Printer running in production)
- Planned: TEK XP20 support
- Planned: IBM xstation support

### ● Fonts

- Solved: Stability of font servers
- Ready: 100dpi font service (fonts must be a little bit smaller)
- Ready: 75dpi font service (fonts must be changed from scalable to scaled)
- Not ready: 125dpi fonts
- Not ready: Some 3270 font configurations
- Planned: Reconfiguration to HEPiX defined ports

### ● Miscellaneous

- Solved: GIGA Router packet splitting bugs
- Not solved: GIGA Router hardware address caching and updating (Upgrade of GIGA Router software end of the year ?)
- Under test: ISS tested with rsh mode (to be tested with queue mode)
- Not ready: Load balancing from main domain desy.de
- Problems: Loadleveler and AFS service with moving/changing IP's
- Under Test: AFS/NFS translation



## Near Future:

- Fully reliable HALE services
- Operatorless operation
- High quality base login services

## Conclusions:

- Effort acceptable for greater numbers
- Standard services for 40 \$ per client
- Add 10 \$ for high availability
- No need for special fault tolerant hardware

