

Search for Z' bosons decaying into charginos in final states with two oppositely charged leptons and missing transverse momentum in pp collisions at $\sqrt{s} = 13$ TeV

The CMS Collaboration*

Abstract

Massive leptophobic Z' bosons decaying to a pair of charginos are searched for in proton-proton collisions at $\sqrt{s} = 13$ TeV, using data samples collected by the CMS experiment in 2016, 2017, and 2018, corresponding to a total integrated luminosity of 138 fb^{-1} . The Z' bosons originate from an additional $U(1)'$ gauge symmetry extended to the minimal supersymmetric standard model. The final state consists of two oppositely charged leptons and missing transverse momentum. The signal extraction is performed with a parametrized neural network. The measurements are found to be consistent with the standard model expectations. Upper limits are set on the Z' boson production cross sections as a function of the Z' and chargino masses. The analysis excludes Z' boson masses up to about 3.5 TeV for the specific case of Z' bosons decaying exclusively to charginos, with the charginos decaying to W bosons and neutralinos.

Submitted to the Journal of High Energy Physics

1 Introduction

Searches for a heavy neutral gauge boson Z' have been performed by the ATLAS and CMS Collaborations since the beginning of data taking at the CERN LHC. These searches primarily focused on direct resonance decays into standard model (SM) particles: lepton pairs, jet pairs, and dibosons [1–5]. The most stringent limits so far have been set by the dilepton searches, the other channels imposing relatively mild constraints.

There are well-motivated theoretical frameworks beyond the SM (BSM), also consistent with the current experimental constraints, suggesting scenarios where resonances decay into new particles. One example is the $U(1)'$ -extended minimal supersymmetric SM (UMSSM) scenario [6–9], derived from embedding the minimal supersymmetric SM (MSSM) [10] in the unified gauge group E_6 . This scenario offers several advantages: a scalar singlet introduced in the model can induce both supersymmetry (SUSY) [10] breaking and the dynamical generation of the μ parameter [9], which would otherwise be introduced unnaturally at the electroweak scale in the MSSM. It also forbids rapid proton decay, without the need to introduce an ad hoc discrete R -parity symmetry.

The $U(1)'$ extension leads to an extra gauge boson, the Z' . In certain charge scenarios, this leads to leptophobic Z' bosons, suppressing the decays of the Z' boson to leptons [9, 11, 12] and circumventing the stringent experimental constraints set by dilepton resonance searches. Instead, the Z' boson decays are dominated by other channels, including decays to SM final states with quark pairs, boson pairs (such as W^+W^- or HZ), neutrino pairs, or SUSY final states with chargino or neutralino pairs, where charginos (neutralinos) are the mass eigenstates of the charged (neutral) superpartners of the SM gauge and Higgs bosons.

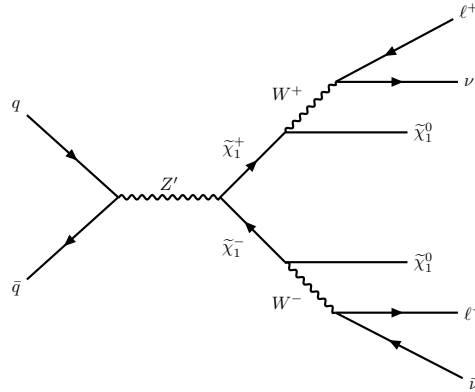

Figure 1: Diagram showing the signal process studied in this analysis: a leptophobic Z' boson decaying into two charginos, each subsequently decaying into a lepton, a neutrino, and a neutralino.

This paper reports a search for leptophobic Z' bosons that decay into two charginos, $\tilde{\chi}_1^\pm$, each of them decaying into a W boson and the lightest neutralino, $\tilde{\chi}_1^0$ (the lightest supersymmetric particle, which is a dark matter candidate and is stable under R -parity conservation, given the $U(1)'$ gauge structure of the UMSSM scenario), with the W bosons decaying leptonically. This process, illustrated in Fig. 1, leads to a distinct signature with two oppositely charged high-momentum leptons (e^+e^- , $\mu^+\mu^-$, or $e^\pm\mu^\mp$) and high missing transverse momentum (p_T^{miss}). Previously reported searches have not addressed this specific scenario. For example, the Z' boson searches in the dilepton channel described in Refs. [1, 2] have neither applied an explicit requirement on p_T^{miss} nor considered the kinematic properties imposed by the intermediate charginos. Moreover, direct chargino pair production searches, such as those reported in

Refs. [13, 14], have not explored the kinematic properties imposed by the assumption that they are produced in the decay of a heavy particle.

The leptophobic Z' boson production cross section is similar to that of the Z' bosons predicted in other models, such as the sequential SM or those from non-supersymmetric E_6 gauge groups [1–4]. In the full UMSSM scenario, including the complete SUSY particle content with their predicted properties, the branching fractions of the Z' boson decay into charginos and of the subsequent decays of the charginos into leptonically decaying W bosons are both of the order of a few percent [9, 11]. In order to extract such small signal from the dominant SM backgrounds, the analysis employs a multivariate analysis approach.

2 The CMS apparatus and event samples

The CMS apparatus is a multipurpose detector [15] designed to trigger on and identify electrons, muons, photons, and (charged and neutral) hadrons [16–18]. A superconducting solenoid of 6 m internal diameter provides a magnetic field of 3.8 T. Within the solenoid volume are the silicon pixel and strip tracker, a crystal electromagnetic calorimeter (ECAL), and a brass and scintillator hadron calorimeter (HCAL), each composed of a barrel and two endcap sections. Forward calorimeters extend the pseudorapidity coverage provided by the barrel and endcap detectors. Muons are measured in gas-ionization detectors (drift tubes, cathode strip chambers, and resistive plate chambers) embedded in the steel flux-return yoke outside the solenoid. Events of interest are selected using a two-tiered trigger system. The first level (L1), composed of custom hardware processors, uses information from the calorimeters and muon detectors to select events at a rate of 100 kHz within a fixed latency of 4 μ s [19]. The second level, consisting of a farm of processors running a faster version of the full event reconstruction software, reduces the rate to around 1 kHz, before data storage [20, 21]. A more detailed description of the CMS detector, together with a definition of the coordinate system used and the relevant kinematic variables, can be found in Refs. [15, 22].

The proton-proton (pp) event samples used in the analysis were collected at a center-of-mass energy of 13 TeV in 2016, 2017, and 2018, with integrated luminosities of 36.3, 41.5, and 59.8 fb^{-1} , respectively [23–25], leading to a total integrated luminosity of 138 fb^{-1} .

The analysis also relies on Monte Carlo (MC) simulated event samples, to evaluate the SM backgrounds and extract the signal yields. The signal events are generated for the exclusive process $pp \rightarrow Z' \rightarrow \tilde{\chi}_1^+ \tilde{\chi}_1^- \rightarrow W^+ \tilde{\chi}_1^0 W^- \tilde{\chi}_1^0 \rightarrow \ell^+ \nu \tilde{\chi}_1^0 \ell^- \nu \tilde{\chi}_1^0$. The hard process is generated at leading order (LO) precision using the MADGRAPH5_aMC@NLO v2.6.5 generator [26], with the NNPDF3.1 LO parton distribution functions (PDFs) [27] and assuming the strong coupling constant $\alpha_S(m_Z) = 0.13$, where m_Z is the mass of the Z boson. The masses of the Z' boson and of the chargino are scanned, respectively, from 1.7 to 4.1 TeV in steps of 400 GeV and from 345 to 1845 GeV in steps of 250 GeV. The neutralino mass is taken to be half of the chargino mass, which arises from the assumption of gaugino mass unification at the grand unified theory (GUT) scale [10, 28]. The events are generated in a theoretical framework that assumes a negligible Z' boson width. The effective cross sections are calculated by setting the $Z' \rightarrow \tilde{\chi}_1^+ \tilde{\chi}_1^- \rightarrow W^+ \tilde{\chi}_1^0 W^- \tilde{\chi}_1^0$ branching fraction to 100%.

The POWHEG v2 [29–32] event generator is used to simulate, at next-to-leading order (NLO) precision in perturbative quantum chromodynamics (QCD), the following SM background processes: $t\bar{t}$ pair production; single top quark production in association with a W boson, and W plus Z boson pair production. The MADGRAPH5_aMC@NLO event generator is used to simulate, at NLO precision, these other SM background processes: Drell–Yan (DY), WZ , $t\bar{t}W$, $t\bar{t}Z$,

WWW, and WWZ. For the SM backgrounds, the NNPDF3.1 NNLO PDF sets are used [27].

To model the fragmentation and parton showering processes, the generated events are processed through PYTHIA [33], using version 8.240. For multi-jet NLO samples, partons in the matrix element calculation are merged with the parton shower using the FxFx prescription [34]. The MC samples are simulated with the CP2 (for the signal, consistent with the LO matrix element) and CP5 (for the SM backgrounds) underlying-event tunes [35]. The simulated events are processed through a detailed simulation of the CMS detector, based on the GEANT4 package [36], using the same trigger and reconstruction algorithms as used to collect and process the data.

3 Object reconstruction, identification, and selection

The objects used in this analysis are reconstructed starting with a particle-flow (PF) algorithm [37], which aims to reconstruct and identify each individual particle in an event, through an optimized combination of information from the various elements of the CMS detector. The energy of the photons is directly obtained from the ECAL measurements. The electron's energy is determined by combining the electron momentum at the primary interaction vertex (as determined by the silicon tracker), the energy of the corresponding ECAL cluster, and the energy sum of all bremsstrahlung photons spatially compatible with originating from the electron track. The energy of muons is obtained from the curvature of the corresponding tracks. The energy of each charged hadron is computed by combining the momentum measured in the tracker with the matching ECAL and HCAL energy deposits, corrected using the response function of the calorimeters to hadronic showers. Finally, the energy of neutral hadrons is obtained from the corresponding corrected ECAL and HCAL energies.

Electrons are reconstructed by associating a track in the silicon layers with a cluster of energy in the ECAL. Their momentum is evaluated by combining the energy measurement in the ECAL with the momentum measurement in the tracker. Electrons from $Z \rightarrow ee$ decays, with transverse momentum $p_T \approx 45$ GeV, have a momentum resolution between 1.6% and 5%; it is generally better in the barrel than in the endcaps and also depends on the bremsstrahlung radiation emitted by the electrons [16, 38, 39]. Electrons are identified by an algorithm based on a boosted decision tree (BDT), selecting a working point with identification efficiency approximately 90%. Isolation variables [16] are included in the BDT training. The electrons are required to have $p_T > 25$ GeV and pseudorapidity $|\eta| < 2.5$, excluding the $1.44 < |\eta| < 1.57$ transition region, situated between the barrel and endcap detectors. They are also required to have relative isolation, I_{PF}^{rel} , smaller than 0.08, computed as the ratio between the sum of the p_T of all PF particles within a cone of radius $\Delta R = 0.3$ around the electron trajectory and the electron p_T , with corrections applied to mitigate the contribution from pileup (i.e., additional pp interactions within the same or nearby bunch crossings).

Muons are measured in the $|\eta| < 2.4$ range, by associating a track in the silicon tracker with a track in the muon detectors, and are required to have $p_T > 25$ GeV. The single-muon trigger efficiency exceeds 90% over the full η range and the efficiency to reconstruct and identify muons is larger than 96%. Muons with p_T up to 100 GeV have a relative transverse momentum resolution of 1% in the barrel and 3% in the endcaps [17]. Muons are identified by applying a set of quality criteria to the candidates, using a working point with an identification efficiency of 95%. Their relative isolation, computed using a cone of radius 0.4, is required to be $I_{PF}^{rel} < 0.15$.

Jets are reconstructed from the PF particles using the infrared- and collinear-safe anti- k_T algorithm [40, 41] with a distance parameter $\Delta R = 0.4$. The jet momentum is determined as the

vectorial sum of all particle momenta in the jet. Simulation studies show that this value is, on average, within 5–10% of the momentum of the jet at the particle level (that is, prior to its detection), over the entire p_T spectrum and detector coverage. Pileup interactions increase the number of tracks and calorimetric energy deposits, thereby increasing the apparent jet momentum.

To mitigate this effect, tracks identified as originating from pileup vertices are discarded and an offset is applied to correct for remaining contributions [42]. The jet energy corrections are derived, from simulation studies, so that the measured (average) jet energy is identical to the particle-level jet energy. In situ measurements of the momentum balance in dijet, photon + jet, Z + jet, and multijet events are used to evaluate residual differences between the jet energy scale in measured and simulated events, so that appropriate corrections can be applied [43]. Additional selection criteria are applied to each jet, to remove jets potentially dominated by instrumental effects or reconstruction failures [42]. Jets overlapping with selected leptons, within a cone of $\Delta R = 0.4$, are rejected. To select true jets and reject instrumental noise, tight selection criteria are imposed on variables related to the energy fractions and relative multiplicities of the various PF candidate types clustered in the jet. The selected jets must have $p_T > 30 \text{ GeV}$ and $|\eta| < 2.4$.

Some of the jets passing the above selection criteria are identified by the DeepCSV algorithm [44] as originating from the hadronization of bottom quarks; they are referred to as b-tagged jets. The chosen working point of the algorithm has an average b tagging efficiency of 70%, for a gluon and light flavor jet misidentification rate of 1% [44].

The missing transverse momentum vector \vec{p}_T^{miss} (of magnitude p_T^{miss}) is computed, for each event, as the projection, in the plane perpendicular to the beam axis, of the negative vector sum of the momenta of all reconstructed PF objects [45]. The contribution from particles from pileup interactions, which degrades the p_T^{miss} resolution, is mitigated using the pileup per particle identification algorithm [46]. Events with anomalous p_T^{miss} , originating from reconstruction or detector failures, are filtered out [45].

4 Analysis method and signal selection

The events are selected using single-electron triggers with electron p_T thresholds of 27 or 32 GeV, and single-muon triggers with muon p_T thresholds of 24 or 27 GeV, depending on the year of data taking. The efficiencies for the single-electron (single-muon) triggers are about 80% (90%) at the p_T efficiency plateau [16, 47]. The events are required to have exactly two oppositely charged leptons (electrons or muons), the leading (trailing) lepton having $p_T > 80$ (40) GeV. The dilepton invariant mass, $m_{\ell\ell}$, is required to be larger than 100 GeV, to suppress backgrounds with on-shell Z bosons. To eliminate most of the DY+jets and $t\bar{t}$ backgrounds, p_T^{miss} is required to be larger than 100 GeV. To further suppress the $t\bar{t}$ background, events with b-tagged jets are rejected. The events passing these criteria are then distributed in three classes, defined by their lepton flavor combinations: e^+e^- , $\mu^+\mu^-$, and $e^\pm\mu^\mp$. The selection is summarized in Table 1.

These event selection criteria reject most of the SM backgrounds, while retaining a high signal selection efficiency. However, the remaining irreducible backgrounds, primarily from the $t\bar{t}$, tW , and WW processes, exhibit features that resemble those of the signal events, so that no single variable exists that effectively discriminates the signal from the backgrounds. Therefore, a multivariate analysis approach is adopted, combining information from the kinematical and topological features that characterize the signal and background processes.

Table 1: Signal event selection and search channels.

Selection variables	Selection criteria
Number of leptons	=2
Opposite charge lepton pairs	= 1 (e^+e^- , $\mu^+\mu^-$, $e^\pm\mu^\mp$)
Leading lepton p_T	>80 GeV
Trailing lepton p_T	>40 GeV
Dilepton invariant mass ($m_{\ell\ell}$)	>100 GeV
Missing transverse momentum (p_T^{miss})	>100 GeV
Number of b jets	=0

The analysis employs a fully connected parametrized neural network (PNN), to overcome the limitations of traditional training approaches. When training a neural network (NN) to extract a signal model with free parameters, such as the particle masses, several approaches can be considered. One of the most common approaches is to train a dedicated NN for a selected set of individual mass points in the signal model. While this method is expected to provide an optimal performance for each of those specific mass points, it does not guarantee a good performance for other mass points. The PNN approach [48] addresses this limitation by including the free model parameters as inputs in the NN training. In our specific analysis, the additional training parameters are the masses of the Z' boson and of the chargino.

The PNN learns nontrivial correlations among the relevant variables and provides a model that maps the input variables to signal- or background-like scores. These PNN scores (ranging between 0 and 1) are then used in a binned likelihood fit that provides the results of the analysis. The PNN training is performed using half of the simulated events (signal and all SM backgrounds considered in this analysis, randomly sampled) that pass the selection criteria described above, except for the b-tagged jet veto requirement. Since the PNN score is not expected to be strongly affected by the b-tagged jet requirement, the training is performed on b-tagged jet inclusive events, thereby increasing the number of events available for training. The remaining half of the events, which are not used for training, are used for the validation of the PNN performance. The training is done independently for each of the search channels, taking into account the cross section of each process along with event reweighting, such that the effective event yields of each signal and the total background are balanced.

The PNN training uses the variables listed below. The variables are selected because they exhibit a good discriminating power between the signal and the SM background processes. For example, the signal features higher average lepton p_T values because of the high mass of the Z' boson and higher p_T^{miss} because the final state includes two massive neutralinos.

- The p_T of the leading (ℓ_1) and trailing (ℓ_2) leptons.
- The dilepton invariant mass, $m_{\ell\ell}$.
- The p_T^{miss} .
- The magnitude of the vectorial sum of the dilepton p_T and \vec{p}_T^{miss} , $|\vec{p}_T(\ell\ell) + \vec{p}_T^{\text{miss}}|$.
- $|\vec{p}_T(\ell\ell) + \vec{p}_T^{\text{miss}}| - p_T(\ell\ell)$, where $p_T(\ell\ell)$ is the magnitude of the dilepton p_T .
- The transverse mass,

$$m_T = 2 p_T(\ell\ell) p_T^{\text{miss}} [1 - \cos \Delta\phi(\vec{\ell\ell}, \vec{p}_T^{\text{miss}})], \quad (1)$$

where $\Delta\phi(\vec{\ell\ell}, \vec{p}_T^{\text{miss}})$ is the azimuthal distance between the dilepton and \vec{p}_T^{miss} .

- The “stransverse mass” [49, 50],

$$M_{T2} = \min_{\vec{p}_T^{\text{miss}(1)} + \vec{p}_T^{\text{miss}(2)} = \vec{p}_T^{\text{miss}}} \left[\max \left(m_T(\ell_1, \vec{p}_T^{\text{miss}}), m_T(\ell_2, \vec{p}_T^{\text{miss}}) \right) \right], \quad (2)$$

where $\vec{p}_T^{\text{miss}(1,2)}$ are the vector p_T of two invisible objects whose momentum sum is \vec{p}_T^{miss} and $m_T(\ell_{1,2}, \vec{p}_T^{\text{miss}})$ are the transverse masses obtained by pairing $\vec{p}_T^{\text{miss}(i)}$ with either of the two leptons. The stransverse mass is a discriminating variable particularly useful in events with more than one invisible particle in the final state. For example, in $t\bar{t}$ events that decay leptonically, M_{T2} exhibits an endpoint at the W boson mass.

These variables are complemented with variables representing angular distances between the various event objects. In the azimuthal dimension, we have the distances between the two leptons, $\Delta\phi(\ell_1, \ell_2)$, between \vec{p}_T^{miss} and the dilepton, $\Delta\phi(\vec{p}_T^{\text{miss}}, \vec{p}_T(\ell_1\ell_2))$, and between \vec{p}_T^{miss} and each of the two leptons, $\Delta\phi(\vec{p}_T^{\text{miss}}, \vec{p}_T(\ell_1))$ and $\Delta\phi(\vec{p}_T^{\text{miss}}, \vec{p}_T(\ell_2))$. For each of these variables, the signal distribution peaks at π , while the background processes have flatter distributions. There is also the angular distance in η and azimuth, $\Delta R = \sqrt{(\Delta\phi)^2 + (\Delta\eta)^2}$, between the two leptons, $\Delta R(\ell_1, \ell_2)$. The signal distribution peaks close to 3 and reaches higher values, while the background processes have broader distributions and mostly populate lower values.

While the set of the most important variables slightly depends on the search channel and assumed signal scenario, the top-ranked variables typically include $p_T(\ell)$, $m_{\ell\ell}$, p_T^{miss} , m_T , and M_{T2} . Figure 2 shows the distributions measured for some variables.

The analysis uses the TensorFlow [51] framework, interfaced with the Keras [52] library. The gradient descent algorithm [53] employed in the PNN assumes that the input variables follow normal Gaussian distributions, while, in reality, they span a wide variety of numerical ranges. Therefore, each variable x is transformed into $(x - \bar{x})/\sigma_x$, where \bar{x} and σ_x are the mean and standard deviation of its distribution. Model structure parameters (e.g., the number of hidden layers) and training process parameters are scanned in a grid search and by using Bayesian optimization methods [54].

Figure 3 shows the performance of the PNN approach with that of an NN model trained on a specific signal point ($m_{Z'} = 2.5$ TeV and $m_{\tilde{\chi}_1^+} = 345$ GeV), using MC simulations of the $e\mu$ search channel with the 2017 integrated luminosity. The comparison uses the Asimov significance (Z_A) [55], defined as

$$\begin{aligned} Z_A^2 &= -2 \ln \frac{\mathcal{L}(\mu = 0 \mid D(s+b))}{\mathcal{L}(\mu = 1 \mid D(s+b))} \\ &= -2 \ln \frac{\prod_i^{\text{bins}} \mathcal{P}(s_i + b_i \mid b_i)}{\prod_i^{\text{bins}} \mathcal{P}(s_i + b_i \mid s_i + b_i)} \\ &= \sum_i^{\text{bins}} 2 \left[(s_i + b_i) \ln \frac{s_i + b_i}{b_i} - s_i \right]. \end{aligned} \quad (3)$$

where μ represents the signal strength (the ratio of the signal yield to the predicted signal yield, where $\mu = 1$ corresponds to the full prediction), $D(s+b)$ denotes pseudo-data assuming the full signal and background yields, \mathcal{P} represents the Poisson distribution, and s_i (b_i) is the number of signal (background) counts in the i^{th} bin of the PNN scores. The two significances coincide at the signal point used in the NN training ($m_{Z'} = 2.5$ TeV and $m_{\tilde{\chi}_1^+} = 345$ GeV), as expected, but the NN significance degrades as the masses deviate from that point. For example,

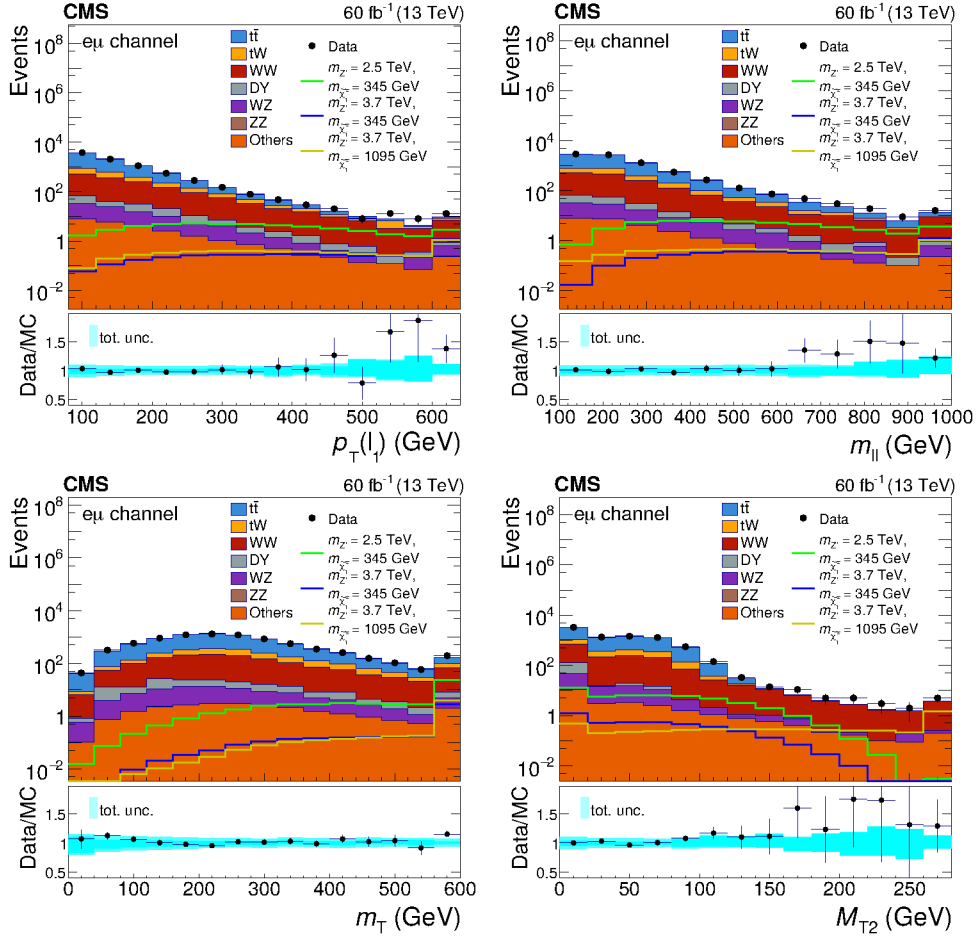

Figure 2: Distributions measured from the $e^\pm\mu^\mp$ sample collected in 2018, for $p_T(\ell_1)$ (upper left), $m_{\ell\ell}$ (upper right), m_T (lower left), and M_{T2} (lower right). Several benchmark signal distributions are overlaid (colored lines), illustrating the separation power between signal and background. The panel under each plot shows the data-to-background ratio, along with the corresponding total uncertainty band (in cyan).

when $m_{Z'}$ = 4.1 TeV, the PNN significance is higher by 11 (17)% for a chargino mass of 345 (845) GeV.

5 Background evaluation

The dominant irreducible SM backgrounds in the signal region (SR) are the $t\bar{t}$, WW, and DY processes, whose shapes in the signal region are evaluated using the simulated events for each process. These backgrounds are normalized using factors obtained by fitting the PNN score distributions in the SR and, simultaneously, in three control regions (CRs) defined so that they are dominated by each of the three SM processes, with negligible signal contamination. The three search channels are analyzed separately and then combined in a fit. The $t\bar{t}$ CR is considered in all three channels, the WW CR is only considered in the $e^\pm\mu^\mp$ channel as its yield is negligible in the other channels, and the DY CR is only considered in the e^+e^- and $\mu^+\mu^-$ channels.

Table 2 lists the selection criteria that define the SRs and CRs. Events with at least one b-tagged jet are used to define the $t\bar{t}$ CR, while those with $40 < m_{\ell\ell} < 100$ GeV define the WW CR. The

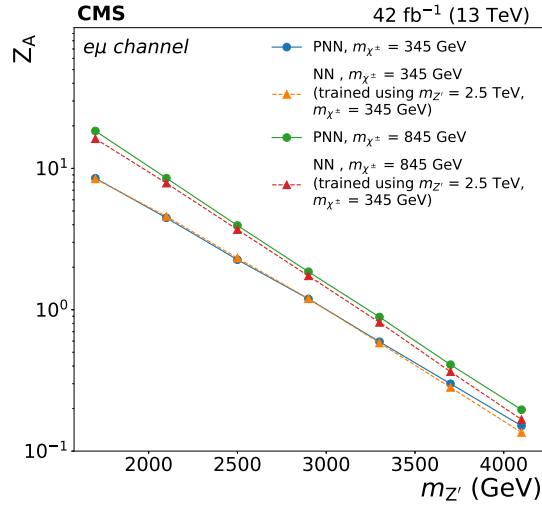

Figure 3: Asimov significance, Z_A , vs. $m_{Z'}$ for the PNN model (circles) and for a NN model trained on a specific signal point (triangles) for the 2017 simulated event sample, in the $e^\pm \mu^\mp$ channel. Two chargino masses have been considered, as indicated.

Table 2: Definitions of the signal and control regions used in the analysis.

Region	p_T^{miss} (GeV)	$m_{\ell\ell}$ (GeV)	b jets	Channels
SR	>100	>100	0	$e^+e^-, \mu^+\mu^-, e^\pm\mu^\mp$
$t\bar{t}$ CR	>100	>100	≥ 1	$e^+e^-, \mu^+\mu^-, e^\pm\mu^\mp$
WW CR	>100	40–100	0	$e^\pm\mu^\mp$
DY CR	30–100	>100	0	$e^+e^-, \mu^+\mu^-$

DY CR is defined by requiring p_T^{miss} to be between 30 and 100 GeV. The same PNN model is deployed in all regions.

Figure 4 shows the PNN score distributions of the measured (merging the three data-taking periods) and simulated SM background events, for the PNN model with $m_{Z'} = 2.5$ TeV and $m_{\tilde{\chi}_1^\pm} = 345$ GeV, for three combinations of CRs and search channels: $t\bar{t}$ and WW CRs for $e^\pm \mu^\mp$ and DY CR for the merged e^+e^- and $\mu^+\mu^-$ channels. The SM distributions in the colored stack show the fitted yields (“Bkg. fit”). The data-to-background ratios are shown using both the raw (“Pre-fit”) and fitted SM yields. The measured distributions are in agreement with the fitted SM backgrounds.

The remaining, subdominant, background processes have a negligible impact in the analysis sensitivity and, therefore, are evaluated from the simulated samples.

6 Systematic uncertainties

Several sources of theoretical and experimental systematic uncertainties listed below affect the shape or normalization of the PNN signal and background distributions. These uncertainties are taken into account through nuisance parameters in the final profile likelihood fit. Effects from a single source of uncertainty are treated as fully correlated across the PNN score bins, whereas independent sources of uncertainty are treated as uncorrelated.

The uncertainties associated with the renormalization (μ_R) and factorization (μ_F) scales are

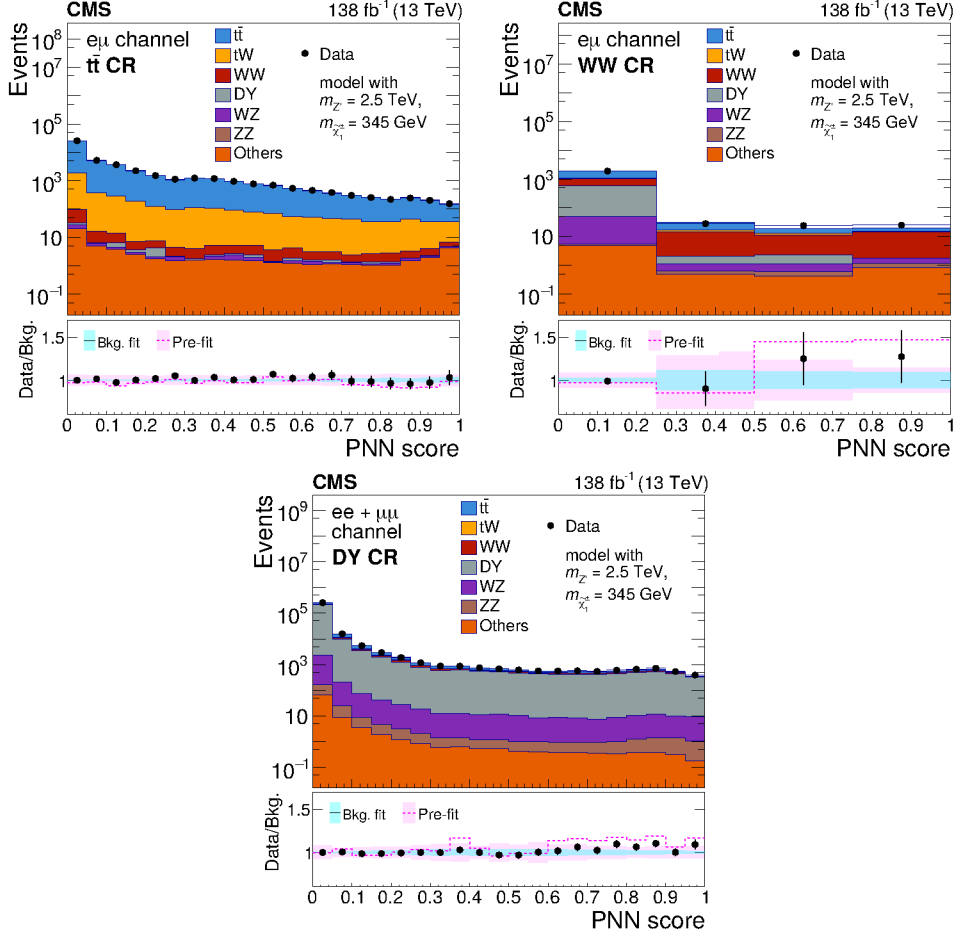

Figure 4: Measured and simulated SM PNN score distributions for a model with $m_{Z'} = 2.5$ TeV and $m_{\tilde{\chi}_1^\pm} = 345$ GeV, for the $t\bar{t}$ (upper left) and WW (upper right) CRs in the $e^\pm\mu^\mp$ channel and for the DY CR in the $e^+e^- + \mu^+\mu^-$ channel (lower). The panel under each plot shows the data-to-background ratios using either a background-only fit (black circles and cyan band) or a pre-fit (magenta dashed line and band). The uncertainties are displayed around the unity line.

evaluated by independently varying μ_R and μ_F by a factor of 2 and 0.5, excluding the two extreme combinations. The uncertainty associated with the PDFs and α_S value is evaluated by reweighting the simulated events using the variations provided by the NNPDF3.1 [27] and PDF4LHC [56] sets, respectively, for the SM backgrounds and signal. The uncertainty from the matching between the matrix element generator and the parton shower in the POWHEG and PYTHIA simulation is evaluated with simulation studies, varying the parameter (h_{damp}) that regulates the first high- p_T emission. Uncertainties in the simulation of the underlying event are estimated by varying the tune settings [35]. To improve the agreement between the measured and simulated top quark p_T spectra in $t\bar{t}$ events, weights are applied to the NLO events to match the p_T distribution predicted at next-to-next-to-leading order (NNLO) [57]. The resulting variation in the prediction after applying the reweighting is taken as the corresponding uncertainty. The backgrounds normalized using factors obtained from the fit ($t\bar{t}$, WW, and DY) are assigned a normalization uncertainty corresponding to the fit uncertainty. The backgrounds directly estimated from the simulated samples (all but $t\bar{t}$, WW, and DY) have a normalization uncertainty equal to twice their theoretical uncertainty.

The integrated luminosities of the 2016, 2017, and 2018 data taking periods have uncertainties

of 1.2%, 2.3%, and 2.5%, respectively [23–25]. These uncertainties are uniformly applied to the simulated events. The number of simulated pileup interactions is estimated assuming a total inelastic pp cross section of 69.2 mb. A corresponding uncertainty is evaluated by varying the total inelastic cross section by $\pm 4.6\%$ [42]. During the 2016 and 2017 data-taking periods, a gradual shift in the timing of the inputs of the ECAL L1 trigger in the forward endcap region ($|\eta| > 2.4$) led to an inefficiency. Also the muon detectors showed a similar trigger inefficiency effect, especially in 2016. Corrections for this effect are applied to simulated events; the corresponding uncertainties are around 1%. Scale factors are applied, as functions of lepton p_T and η , to account for differences between the measured and simulated samples regarding the lepton reconstruction, identification, and isolation efficiencies. The uncertainties associated with the calculation of these factors are propagated as systematic uncertainties. Uncertainties in the evaluation of the jet energy scale are taken into account by varying the jet momenta in simulated events, separately for the overall energy scale, differences in flavor response, residual differences between the energy scale measurements, etc. Uncertainties in the jet energy resolution are evaluated by varying the difference between the reconstructed and particle-level jet energies, or by smearing the measured jet energy if no matching particle-level jet could be found [43]. These jet energy scale and resolution variations are also propagated to \vec{p}_T^{miss} . Differences between the measured and simulated b jet tagging and light-quark or gluon jet mistagging scale factors are assigned as systematic uncertainties, as functions of p_T and η . Statistical uncertainties resulting from the finite size of the simulated samples are addressed using the Barlow–Beeston method [58]: in bins with more than 100 effective events a single Gaussian-constrained nuisance parameter is introduced for the sum of process yields, while for the other bins Poisson-constrained parameters are introduced for each process.

Among the systematic sources, the dominant contributions arise from the normalization uncertainty for backgrounds normalized using fit factors (around 12% of the fit uncertainty) and from the b jet tagging scale factor uncertainty (around 10% of the prior uncertainty). The other sources have a relatively mild impact on the results.

7 Results and interpretation

The search for the Z' signal is performed by fitting the measured PNN score distributions, in the SR for each of the three search channels. These distributions depend on the assumed Z' and $\tilde{\chi}_1^\pm$ masses. The CRs are combined and fitted simultaneously with the SRs, to determine the normalization factors for the dominant background processes.

Figure 5 presents the measured and estimated background PNN score distributions in the SR of each of the three search channels, for a model with $m_{Z'} = 2.5 \text{ TeV}$ and $m_{\tilde{\chi}_1^\pm} = 345 \text{ GeV}$. In each panel, the stack of SM background contributions corresponds to the background-only fit. The panels under each plot show the data-to-background ratios in both the “pre-fit” and “background-only fit” options, also displaying the total uncertainties, computed as the sum in quadrature of the statistical and systematic terms. The normalization factors of the dominant background processes are primarily determined from the CRs and the background-rich bins in the SRs. For the signal mass point hypothesis shown in Fig. 5, the fitted normalization factors are: 1.01 ± 0.03 for $t\bar{t}$, 1.12 ± 0.13 for WW , and 1.14 ± 0.04 for DY . The uncertainties (from the fit) are smaller for the processes with large yields in the CRs.

In the e^+e^- channel, the fit shows agreement between the measured PNN distribution and the SM expectation. In the $\mu^+\mu^-$ channel, a mild excess is observed in the signal-like bin (PNN score close to 1), with a local significance of 2 to 3 standard deviations, depending on

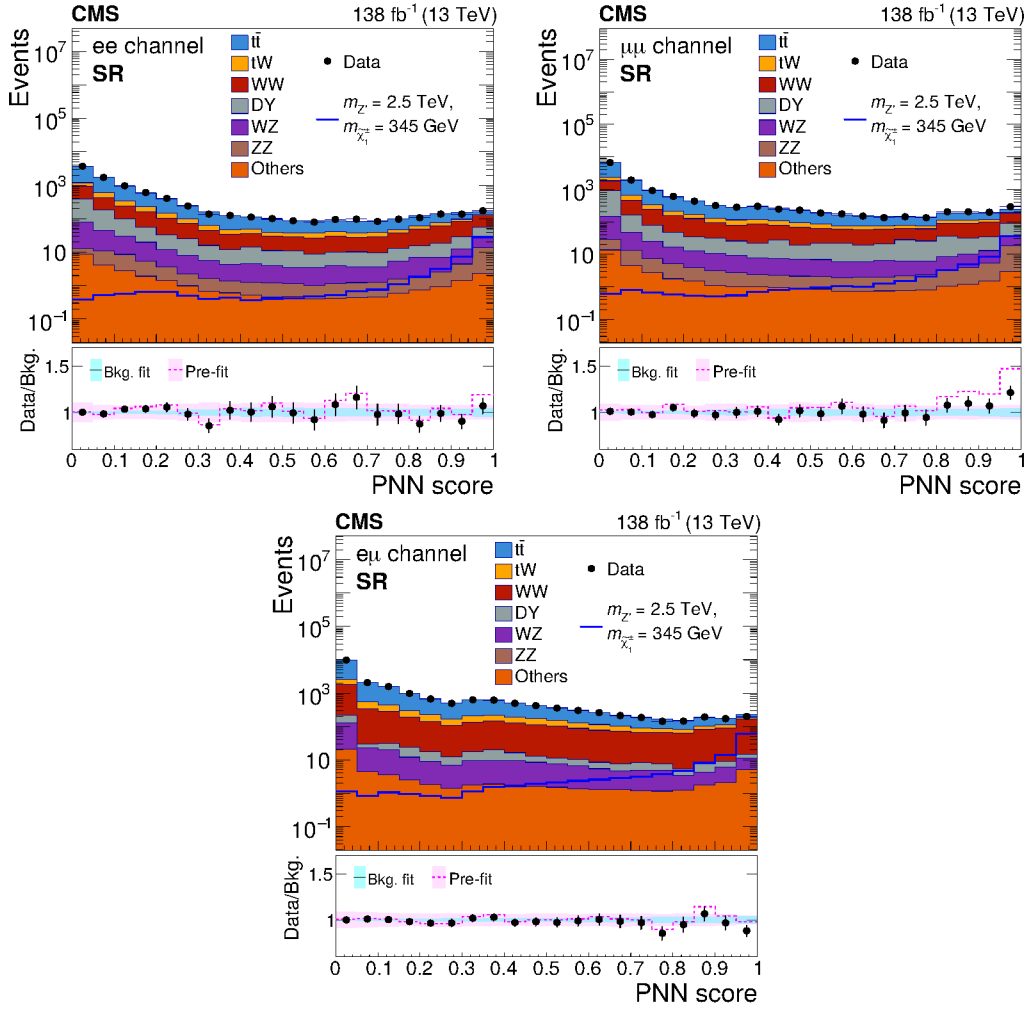

Figure 5: Measured and estimated background PNN score distributions, in the SRs of the three search channels. Signal distributions for a model with $m_{Z'} = 2.5$ TeV and $m_{\tilde{\chi}_1^\pm} = 345$ GeV are superimposed on the plots. The panel under each plot shows the data-to-background ratios using either a background-only fit (black circles and cyan band) or a pre-fit (magenta dashed line and band). The uncertainties are displayed around the unity line.

the assumed signal mass hypothesis. The $e^\pm\mu^\mp$ channel, instead, shows a mild deficit in the signal-like bin.

A statistical interpretation has been conducted by testing the SM hypothesis against the Z' boson hypothesis. Upper limits on the Z' boson production cross section are calculated at 95% confidence level (CL) using a modified frequentist approach and the CL_s criterion, implemented through an asymptotic approximation [55, 59–61]. The limits are computed using the COMBINE statistical analysis tool [62], which is based on the ROOFIT [63] and ROOSTATS [64] frameworks. Figure 6 shows the observed and expected $pp \rightarrow Z'$ cross section upper limits in the $m_{Z'}$ vs. $m_{\tilde{\chi}_1^\pm}$ plane, while Fig. 7 shows the corresponding limits as a function of $m_{Z'}$, for several $m_{\tilde{\chi}_1^\pm}$ values.

The cross section limits are computed for an integrated luminosity of 138 fb^{-1} and assuming that the $Z' \rightarrow \tilde{\chi}_1^+ \tilde{\chi}_1^- \rightarrow W^+ \tilde{\chi}_1^0 W^- \tilde{\chi}_1^0$ branching fraction is 100%. The Z' boson width is considered negligible and the neutralino mass is set to be half of the chargino mass. The obtained

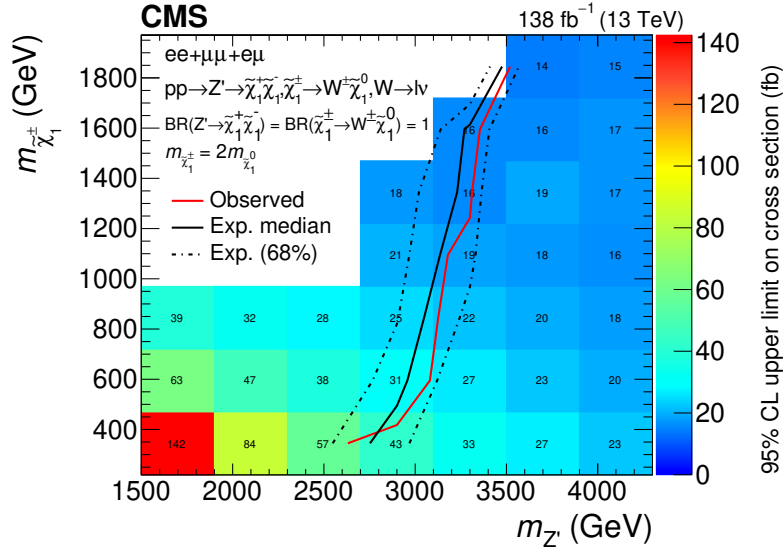

Figure 6: Upper limits, at 95% CL, on the $pp \rightarrow Z'$ cross section, in the Z' boson mass vs. $\tilde{\chi}_1^\pm$ mass plane, combining the e^+e^- , $\mu^+\mu^-$, and $e^\pm\mu^\mp$ channels, as determined from the measured data (red line) and as expected from the simulation studies (black lines: median exclusion in solid and 68% quantiles in dashed). The region to the left of the curves is excluded. The color grid shows median expected upper limits.

limits are mostly driven by the $e^\pm\mu^\mp$ channel, which has a better sensitivity because its signal (and background) event yields are higher than those of the same-flavor channels. For a fixed Z' boson mass, the sensitivity improves for higher $\tilde{\chi}_1^\pm$ masses, given the improved signal selection efficiency. Although the sensitivity is quoted for a narrow-width Z' resonance, it is expected to be similar for wider resonances with a width-to-mass ratio up to 20%, as the kinematic distributions are found to be comparable to those in the narrow-width case.

For the scenario with $m_{\tilde{\chi}_1^\pm} \approx 1.8$ TeV, the measurement excludes the existence of Z' bosons with mass up to 3.5 TeV. Assuming that the Z' boson has a mass of 2.9 TeV and only decays to a chargino pair, the observations exclude charginos in the 400–1400 GeV mass range.

Tabulated results are provided in the HEPData record for this analysis [65].

8 Summary

A search has been conducted for a leptophobic Z' boson decaying into two charginos, which subsequently decay into W bosons and neutralinos. A data sample of proton-proton collisions at a center-of-mass energy of 13 TeV, corresponding to an integrated luminosity of 138 fb^{-1} , was analyzed. This is the first search for this process using LHC data. An analysis was designed in the dilepton plus missing transverse momentum final state, in the e^+e^- , $\mu^+\mu^-$, and $e^\pm\mu^\mp$ channels. A parametrized neural network was employed to enhance the signal sensitivity. The analysis was interpreted using simplified model spectra featuring the production and decay process of the leptophobic Z' boson derived from the $U(1)'$ extension of the minimal supersymmetric standard model. The measurements were found to be consistent with the standard model expectations. Upper limits on the Z' boson production cross section were presented in the Z' boson mass vs. chargino mass plane, with $m_{\tilde{\chi}_1^\pm} = 2 m_{\tilde{\chi}_1^0}$. The analysis excludes Z' boson masses up to about 3.5 TeV for the specific case of Z' bosons decaying exclusively to

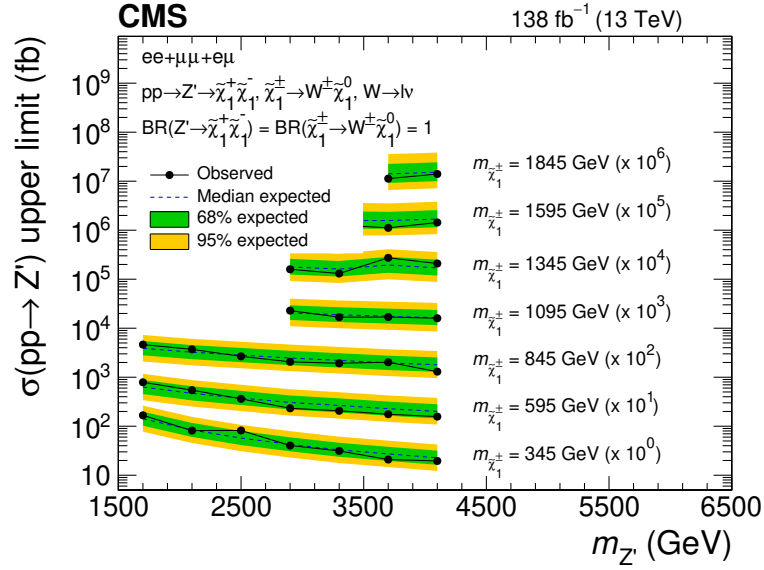

Figure 7: Upper limits, at 95% CL, on the $pp \rightarrow Z'$ cross section, vs. Z' boson mass for several $\tilde{\chi}_1^\pm$ mass values, combining the e^+e^- , $\mu^+\mu^-$, and $e^\pm\mu^\mp$ channels, as determined from the measured data (black circles) and as expected from the simulation studies (dashed lines with green and yellow uncertainty bands). The limits for different $m_{\tilde{\chi}_1^\pm}$ values are shifted vertically, for visibility purposes.

charginos, with the charginos decaying to W bosons and neutralinos. Under the assumption of 2.9 TeV Z' boson decaying exclusively to charginos, observations rule out chargino masses in the 400–1400 GeV range.

Acknowledgments

We congratulate our colleagues in the CERN accelerator departments for the excellent performance of the LHC and thank the technical and administrative staffs at CERN and at other CMS institutes for their contributions to the success of the CMS effort. In addition, we gratefully acknowledge the computing centers and personnel of the Worldwide LHC Computing Grid and other centers for delivering so effectively the computing infrastructure essential to our analyses. Finally, we acknowledge the enduring support for the construction and operation of the LHC, the CMS detector, and the supporting computing infrastructure provided by the following funding agencies: SC (Armenia), BMBWF and FWF (Austria); FNRS and FWO (Belgium); CNPq, CAPES, FAPERJ, FAPERGS, and FAPESP (Brazil); MES and BNSF (Bulgaria); CERN; CAS, MoST, and NSFC (China); MINCIENCIAS (Colombia); MSES and CSF (Croatia); RIF (Cyprus); SENESCYT (Ecuador); ERC PRG and PSG, TARISTU24-TK10 and MoER TK202 (Estonia); Academy of Finland, MEC, and HIP (Finland); CEA and CNRS/IN2P3 (France); SRNSF (Georgia); BMFTR, DFG, and HGF (Germany); GSRI (Greece); NKFIH (Hungary); DAE and DST (India); IPM (Iran); SFI (Ireland); INFN (Italy); MSIT and NRF (Republic of Korea); MES (Latvia); LMTLT (Lithuania); MOE and UM (Malaysia); BUAP, CINVESTAV, CONACYT, LNS, SEP, and UASLP-FAI (Mexico); MOS (Montenegro); MBIE (New Zealand); PAEC (Pakistan); MES, NSC, and NAWA (Poland); FCT (Portugal); MESTD (Serbia); MICIU/AEI and PCTI (Spain); MOSTR (Sri Lanka); Swiss Funding Agencies (Switzerland); MST (Taipei); MHESI (Thailand); TUBITAK and TENMAK (Türkiye); NASU (Ukraine); STFC (United Kingdom); DOE and NSF (USA).

Individuals have received support from the Marie-Curie program and the European Research Council and Horizon 2020 Grant, contract Nos. 675440, 724704, 752730, 758316, 765710, 824093, 101115353, 101002207, 101001205, and COST Action CA16108 (European Union); the Leventis Foundation; the Alfred P. Sloan Foundation; the Alexander von Humboldt Foundation; the Science Committee, project no. 22rl-037 (Armenia); the Fonds pour la Formation à la Recherche dans l'Industrie et dans l'Agriculture (FRIA) and Fonds voor Wetenschappelijk Onderzoek contract No. 1228724N (Belgium); the Beijing Municipal Science & Technology Commission, No. Z191100007219010, the Fundamental Research Funds for the Central Universities, the Ministry of Science and Technology of China under Grant No. 2023YFA1605804, the Natural Science Foundation of China under Grant No. 12535004, and USTC Research Funds of the Double First-Class Initiative No. YD2030002017 (China); the Ministry of Education, Youth and Sports (MEYS) of the Czech Republic; the Shota Rustaveli National Science Foundation, grant FR-22-985 (Georgia); the Deutsche Forschungsgemeinschaft (DFG), among others, under Germany's Excellence Strategy – EXC 2121 “Quantum Universe” – 390833306, and under project number 400140256 - GRK2497; the Hellenic Foundation for Research and Innovation (HFRI), Project Number 2288 (Greece); the Hungarian Academy of Sciences, the New National Excellence Program - ÚNKP, the NKFIH research grants K 131991, K 133046, K 138136, K 143460, K 143477, K 146913, K 146914, K 147048, 2020-2.2.1-ED-2021-00181, TKP2021-NKTA-64, and 2025-1.1.5-NEMZ_KI-2025-00004 (Hungary); the Council of Science and Industrial Research, India; ICSC – National Research Center for High Performance Computing, Big Data and Quantum Computing, FAIR – Future Artificial Intelligence Research, and CUP I53D23001070006 (Mission 4 Component 1), funded by the NextGenerationEU program, the Italian Ministry of University and Research (MUR) under Bando PRIN 2022 – CUP I53C24002390006, PRIN PRIMULA 2022RBYK7T (Italy); the Latvian Council of Science; the Ministry of Education and Science, project no. 2022/WK/14, and the National Science Center, contracts Opus 2021/41/B/ST2/01369, 2021/43/B/ST2/01552, 2023/49/B/ST2/03273, and the NAWA contract BPN/PPO/2021/1/00011 (Poland); the Fundação para a Ciência e a Tecnologia (Portugal); the National Priorities Research Program by Qatar National Research Fund; MICIU/AEI/10.13039/501100011033, ERDF/EU, “European Union NextGenerationEU/PRTR”, projects PID2022-142604OB-C21, PID2022-139519OB-C21, PID2023-147706NB-I00, PID2023-148896NB-I00, PID2023-146983NB-I00, PID2023-147115NB-I00, PID2023-148418NB-C41, PID2023-148418NB-C42, PID2023-148418NB-C43, PID2023-148418NB-C44, PID2024-158190NB-C22, RYC2021-033305-I, RYC2024-048719-I, CNS2023-144781, CNS2024-154769 and Plan de Ciencia, Tecnología e Innovación de Asturias, Spain; the Chulalongkorn Academic into Its 2nd Century Project Advancement Project, the National Science, Research and Innovation Fund program IND_FF.68.369.2300.097, and the Program Management Unit for Human Resources & Institutional Development, Research and Innovation, grant B39G680009 (Thailand); the Eric & Wendy Schmidt Fund for Strategic Innovation through the CERN Next Generation Triggers project under grant agreement number SIF-2023-004; the Kavli Foundation; the Nvidia Corporation; the SuperMicro Corporation; the Welch Foundation, contract C-1845; and the Weston Havens Foundation (USA).

Data availability

Release and preservation of data used by the CMS Collaboration as the basis for publications is guided by the CMS data preservation, re-use and open access policy.

References

- [1] ATLAS Collaboration, “Search for high-mass dilepton resonances using 139 fb⁻¹ of pp collision data collected at $\sqrt{s} = 13$ TeV with the ATLAS detector”, *Phys. Lett. B* **796** (2019) 68, doi:10.1016/j.physletb.2019.07.016, arXiv:1903.06248.
- [2] CMS Collaboration, “Search for resonant and nonresonant new phenomena in high-mass dilepton final states at $\sqrt{s} = 13$ TeV”, *JHEP* **07** (2021) 208, doi:10.1007/JHEP07(2021)208, arXiv:2103.02708.
- [3] CMS Collaboration, “Search for high mass dijet resonances with a new background prediction method in proton-proton collisions at $\sqrt{s} = 13$ TeV”, *JHEP* **05** (2020) 033, doi:10.1007/JHEP05(2020)033, arXiv:1911.03947.
- [4] ATLAS Collaboration, “Search for heavy diboson resonances in semileptonic final states in pp collisions at $\sqrt{s} = 13$ TeV with the ATLAS detector”, *Eur. Phys. J. C* **80** (2020) 1165, doi:10.1140/epjc/s10052-020-08554-y, arXiv:2004.14636.
- [5] CMS Collaboration, “Search for new heavy resonances decaying to WW, WZ, ZZ, WH, or ZH boson pairs in the all-jets final state in proton-proton collisions at $\sqrt{s} = 13$ TeV”, *Phys. Lett. B* **844** (2023) 137813, doi:10.1016/j.physletb.2023.137813, arXiv:2210.00043.
- [6] G. Corcella and S. Gentile, “Heavy neutral gauge bosons at the LHC in an extended MSSM”, *Nucl. Phys. B* **866** (2013) 293, doi:10.1016/j.nuclphysb.2012.09.009, arXiv:1205.5780. [Erratum: doi:10.1016/j.nuclphysb.2012.11.024].
- [7] J. L. Hewett and T. G. Rizzo, “Low-energy phenomenology of superstring inspired E(6) models”, *Phys. Rept.* **183** (1989) 193, doi:10.1016/0370-1573(89)90071-9.
- [8] P. Langacker, “The physics of heavy Z' gauge bosons”, *Rev. Mod. Phys.* **81** (2009) 1199, doi:10.1103/RevModPhys.81.1199, arXiv:0801.1345.
- [9] J. Y. Araz, G. Corcella, M. Frank, and B. Fuks, “Loopholes in Z' searches at the LHC: exploring supersymmetric and leptophobic scenarios”, *JHEP* **02** (2018) 092, doi:10.1007/JHEP02(2018)092, arXiv:1711.06302.
- [10] S. P. Martin, “A supersymmetry primer”, *Adv. Ser. Direct. High Energy Phys.* **18** (1998) 1, doi:10.1142/9789812839657_0001, arXiv:hep-ph/9709356.
- [11] M. Frank, Y. Hiçiyılmaz, S. Moretti, and Ö. Özdal, “Leptophobic Z' bosons in the secluded UMSSM”, *Phys. Rev. D* **102** (2020) 115025, doi:10.1103/PhysRevD.102.115025, arXiv:2005.08472.
- [12] M. Frank, Y. Hiçiyılmaz, S. Moretti, and Ö. Özdal, “E₆ motivated UMSSM confronts experimental data”, *JHEP* **05** (2020) 123, doi:10.1007/JHEP05(2020)123, arXiv:2004.01415.
- [13] ATLAS Collaboration, “Search for direct pair production of sleptons and charginos decaying to two leptons and neutralinos with mass splittings near the W-boson mass in $\sqrt{s} = 13$ TeV pp collisions with the ATLAS detector”, *JHEP* **06** (2023) 031, doi:10.1007/JHEP06(2023)031, arXiv:2209.13935.

-
- [14] CMS Collaboration, “Combined search for electroweak production of winos, binos, higgsinos, and sleptons in proton-proton collisions at $\sqrt{s} = 13$ TeV”, *Phys. Rev. D* **109** (2024) 112001, doi:10.1103/PhysRevD.109.112001, arXiv:2402.01888.
- [15] CMS Collaboration, “The CMS experiment at the CERN LHC”, *JINST* **3** (2008) S08004, doi:10.1088/1748-0221/3/08/S08004.
- [16] CMS Collaboration, “Electron and photon reconstruction and identification with the CMS experiment at the CERN LHC”, *JINST* **16** (2021) P05014, doi:10.1088/1748-0221/16/05/P05014, arXiv:2012.06888.
- [17] CMS Collaboration, “Performance of the CMS muon detector and muon reconstruction with proton-proton collisions at $\sqrt{s} = 13$ TeV”, *JINST* **13** (2018) P06015, doi:10.1088/1748-0221/13/06/P06015, arXiv:1804.04528.
- [18] CMS Collaboration, “Description and performance of track and primary-vertex reconstruction with the CMS tracker”, *JINST* **9** (2014) P10009, doi:10.1088/1748-0221/9/10/P10009, arXiv:1405.6569.
- [19] CMS Collaboration, “Performance of the CMS Level-1 trigger in proton-proton collisions at $\sqrt{s} = 13$ TeV”, *JINST* **15** (2020) P10017, doi:10.1088/1748-0221/15/10/P10017, arXiv:2006.10165.
- [20] CMS Collaboration, “The CMS trigger system”, *JINST* **12** (2017) P01020, doi:10.1088/1748-0221/12/01/P01020, arXiv:1609.02366.
- [21] CMS Collaboration, “Performance of the CMS high-level trigger during LHC Run 2”, *JINST* **19** (2024) P11021, doi:10.1088/1748-0221/19/11/P11021, arXiv:2410.17038.
- [22] CMS Collaboration, “Development of the CMS detector for the CERN LHC Run 3”, *JINST* **19** (2024) P05064, doi:10.1088/1748-0221/19/05/P05064, arXiv:2309.05466.
- [23] CMS Collaboration, “Precision luminosity measurement in proton-proton collisions at $\sqrt{s} = 13$ TeV in 2015 and 2016 at CMS”, *Eur. Phys. J. C* **81** (2021) 800, doi:10.1140/epjc/s10052-021-09538-2, arXiv:2104.01927.
- [24] CMS Collaboration, “CMS luminosity measurement for the 2017 data-taking period at $\sqrt{s} = 13$ TeV”, CMS Physics Analysis Summary CMS-PAS-LUM-17-004, 2018.
- [25] CMS Collaboration, “CMS luminosity measurement for the 2018 data-taking period at $\sqrt{s} = 13$ TeV”, CMS Physics Analysis Summary CMS-PAS-LUM-18-002, 2019.
- [26] J. Alwall et al., “The automated computation of tree-level and next-to-leading order differential cross sections, and their matching to parton shower simulations”, *JHEP* **07** (2014) 079, doi:10.1007/JHEP07(2014)079, arXiv:1405.0301.
- [27] NNPDF Collaboration, “Parton distributions from high-precision collider data”, *Eur. Phys. J. C* **77** (2017) 663, doi:10.1140/epjc/s10052-017-5199-5, arXiv:1706.00428.
- [28] Particle Data Group, S. Navas et al., “Review of particle physics”, *Phys. Rev. D* **110** (2024) 030001, doi:10.1103/PhysRevD.110.030001.



- [29] P. Nason, “A new method for combining NLO QCD with shower Monte Carlo algorithms”, *JHEP* **11** (2004) 040, doi:10.1088/1126-6708/2004/11/040, arXiv:hep-ph/0409146.
- [30] S. Frixione, P. Nason, and C. Oleari, “Matching NLO QCD computations with parton shower simulations: the POWHEG method”, *JHEP* **11** (2007) 070, doi:10.1088/1126-6708/2007/11/070, arXiv:0709.2092.
- [31] S. Alioli, P. Nason, C. Oleari, and E. Re, “A general framework for implementing NLO calculations in shower Monte Carlo programs: the POWHEG BOX”, *JHEP* **06** (2010) 043, doi:10.1007/JHEP06(2010)043, arXiv:1002.2581.
- [32] S. Frixione, P. Nason, and G. Ridolfi, “A positive-weight next-to-leading-order Monte Carlo for heavy flavour hadroproduction”, *JHEP* **09** (2007) 126, doi:10.1088/1126-6708/2007/09/126, arXiv:0707.3088.
- [33] T. Sjöstrand et al., “An introduction to PYTHIA 8.2”, *Comput. Phys. Commun.* **191** (2015) 159, doi:10.1016/j.cpc.2015.01.024, arXiv:1410.3012.
- [34] R. Frederix and S. Frixione, “Merging meets matching in MC@NLO”, *JHEP* **12** (2012) 061, doi:10.1007/JHEP12(2012)061, arXiv:1209.6215.
- [35] CMS Collaboration, “Extraction and validation of a new set of CMS PYTHIA8 tunes from underlying-event measurements”, *Eur. Phys. J. C* **80** (2020) 4, doi:10.1140/epjc/s10052-019-7499-4, arXiv:1903.12179.
- [36] GEANT4 Collaboration, “GEANT4—a simulation toolkit”, *Nucl. Instrum. Meth. A* **506** (2003) 250, doi:10.1016/S0168-9002(03)01368-8.
- [37] CMS Collaboration, “Particle-flow reconstruction and global event description with the CMS detector”, *JINST* **12** (2017) P10003, doi:10.1088/1748-0221/12/10/P10003, arXiv:1706.04965.
- [38] CMS Collaboration, “ECAL 2016 refined calibration and Run 2 summary plots”, CMS Detector Performance Note CMS-DP-2020-021, 2020.
- [39] CMS Collaboration, “Performance of the CMS electromagnetic calorimeter in pp collisions at $\sqrt{s} = 13$ TeV”, *JINST* **19** (2024) P09004, doi:10.1088/1748-0221/19/09/P09004, arXiv:2403.15518.
- [40] M. Cacciari, G. P. Salam, and G. Soyez, “The anti- k_T jet clustering algorithm”, *JHEP* **04** (2008) 063, doi:10.1088/1126-6708/2008/04/063, arXiv:0802.1189.
- [41] M. Cacciari, G. P. Salam, and G. Soyez, “FastJet user manual”, *Eur. Phys. J. C* **72** (2012) 1896, doi:10.1140/epjc/s10052-012-1896-2, arXiv:1111.6097.
- [42] CMS Collaboration, “Pileup mitigation at CMS in 13 TeV data”, *JINST* **15** (2020) P09018, doi:10.1088/1748-0221/15/09/P09018, arXiv:2003.00503.
- [43] CMS Collaboration, “Jet energy scale and resolution in the CMS experiment in pp collisions at 8 TeV”, *JINST* **12** (2017) P02014, doi:10.1088/1748-0221/12/02/P02014, arXiv:1607.03663.
- [44] CMS Collaboration, “Identification of heavy-flavour jets with the CMS detector in pp collisions at 13 TeV”, *JINST* **13** (2018) P05011, doi:10.1088/1748-0221/13/05/P05011, arXiv:1712.07158.

- [45] CMS Collaboration, “Performance of missing transverse momentum reconstruction in proton-proton collisions at $\sqrt{s} = 13$ TeV using the CMS detector”, *JINST* **14** (2019) P07004, doi:10.1088/1748-0221/14/07/P07004, arXiv:1903.06078.
- [46] D. Bertolini, P. Harris, M. Low, and N. Tran, “Pileup per particle identification”, *JHEP* **10** (2014) 059, doi:10.1007/JHEP10(2014)059, arXiv:1407.6013.
- [47] CMS Collaboration, “Performance of the CMS muon trigger system in proton-proton collisions at $\sqrt{s} = 13$ TeV”, *JINST* **16** (2021) P07001, doi:10.1088/1748-0221/16/07/P07001, arXiv:2102.04790.
- [48] P. Baldi et al., “Parameterized neural networks for high-energy physics”, *Eur. Phys. J. C* **76** (2016) 235, doi:10.1140/epjc/s10052-016-4099-4, arXiv:1601.07913.
- [49] C. G. Lester and D. J. Summers, “Measuring masses of semiinvisibly decaying particles pair produced at hadron colliders”, *Phys. Lett. B* **463** (1999) 99, doi:10.1016/S0370-2693(99)00945-4, arXiv:hep-ph/9906349.
- [50] A. Barr, C. Lester, and P. Stephens, “A variable for measuring masses at hadron colliders when missing energy is expected; m_{T2} : the truth behind the glamour”, *J. Phys. G* **29** (2003) 2343, doi:10.1088/0954-3899/29/10/304, arXiv:hep-ph/0304226.
- [51] M. Abadi et al., “TensorFlow: Large-scale machine learning on heterogeneous systems”, technical report, 2015. arXiv:1605.08695, Software available from tensorflow.org.
- [52] F. Chollet et al., “Keras”. <https://keras.io>, 2015.
- [53] S. Ruder, “An overview of gradient descent optimization algorithms”, 2016. arXiv:1609.04747.
- [54] B. Shahriari et al., “Taking the human out of the loop: A review of Bayesian optimization”, *Proceedings of the IEEE* **104** (2016) 148, doi:10.1109/JPROC.2015.2494218.
- [55] G. Cowan, K. Cranmer, E. Gross, and O. Vitells, “Asymptotic formulae for likelihood-based tests of new physics”, *Eur. Phys. J. C* **71** (2011) 1554, doi:10.1140/epjc/s10052-011-1554-0, arXiv:1007.1727. [Erratum: doi:10.1140/epjc/s10052-013-2501-z].
- [56] J. Butterworth et al., “PDF4LHC recommendations for LHC Run II”, *J. Phys. G* **43** (2016) 023001, doi:10.1088/0954-3899/43/2/023001, arXiv:1510.03865.
- [57] M. Czakon et al., “Top-pair production at the LHC through NNLO QCD and NLO EW”, *JHEP* **10** (2017) 186, doi:10.1007/JHEP10(2017)186, arXiv:1705.04105.
- [58] R. J. Barlow and C. Beeston, “Fitting using finite monte carlo samples”, *Comput. Phys. Commun.* **77** (1993) 219, doi:10.1016/0010-4655(93)90005-w.
- [59] T. Junk, “Confidence level computation for combining searches with small statistics”, *Nucl. Instrum. Meth. A* **434** (1999) 435, doi:10.1016/S0168-9002(99)00498-2, arXiv:hep-ex/9902006.
- [60] A. L. Read, “Presentation of search results: The CL_s technique”, *J. Phys. G* **28** (2002) 2693, doi:10.1088/0954-3899/28/10/313.



















-
- [61] ATLAS and CMS Collaborations, and LHC Higgs Combination Group, “Procedure for the LHC Higgs boson search combination in Summer 2011”, Technical Report CMS-NOTE-2011-005, ATL-PHYS-PUB-2011-11, 2011.
- [62] CMS Collaboration, “The CMS Statistical Analysis and Combination Tool: Combine”, *Comput. Softw. Big Sci.* **8** (2024) 19, doi:10.1007/s41781-024-00121-4, arXiv:2404.06614.
- [63] W. Verkerke and D. P. Kirkby, “The RooFit toolkit for data modeling”, in *CHEP03 Computing in High Energy and Nuclear Physics 2003 Conference Proceedings*, L. Lyons and M. Karagoz, eds. 2003. arXiv:physics/0306116.
- [64] L. Moneta et al., “The RooStats Project”, *PoS ACAT2010* (2010) 057, doi:10.22323/1.093.0057, arXiv:1009.1003.
- [65] HEPData record for this analysis, 2025. doi:10.17182/hepdata.166017.

A The CMS Collaboration

Yerevan Physics Institute, Yerevan, Armenia

A. Hayrapetyan, V. Makarenko , A. Tumasyan¹ 

















Institut für Hochenergiephysik, Vienna, Austria

W. Adam , J.W. Andrejkovic, L. Benato , T. Bergauer , M. Dragicevic , C. Giordano , P.S. Hussain , M. Jeitler² , N. Krammer , A. Li , D. Liko , M. Matthewman, I. Mikulec , J. Schieck² , R. Schöfbeck² , D. Schwarz , M. Shooshtari , M. Sonawane , W. Waltenberger , C.-E. Wulz² 















Universiteit Antwerpen, Antwerpen, Belgium

T. Janssen , H. Kwon , D. Ocampo Henao , T. Van Laer , P. Van Mechelen 

Vrije Universiteit Brussel, Brussel, Belgium

J. Bierkens , N. Breugelmans, J. D'Hondt , S. Dansana , A. De Moor , M. Delcourt , F. Heyen, Y. Hong , P. Kashko , S. Lowette , I. Makarenko , D. Müller , J. Song , S. Tavernier , M. Tytgat³ , G.P. Van Onsem , S. Van Putte , D. Vannerom 















Université Libre de Bruxelles, Bruxelles, Belgium

B. Bilin , B. Clerbaux , A.K. Das, I. De Bruyn , G. De Lentdecker , H. Evard , L. Favart , P. Gianneios , A. Khalilzadeh, F.A. Khan , A. Malara , M.A. Shahzad, L. Thomas , M. Vanden Bemden , C. Vander Velde , P. Vanlaer , F. Zhang 











Ghent University, Ghent, Belgium

M. De Coen , D. Dobur , G. Gokbulut , J. Knolle , D. Marckx , K. Skovpen , A.M. Tomaru, N. Van Den Bossche , J. van der Linden , J. Vandenbroeck , L. Wezenbeek 





















Université Catholique de Louvain, Louvain-la-Neuve, Belgium

S. Bein , A. Benecke , A. Bethani , G. Bruno , A. Cappati , J. De Favereau De Jeneret , C. Delaere , F. Gameiro Casalinho , A. Giammanco , A.O. Guzel , V. Lemaitre, J. Lidrych , P. Malek , P. Mastrapasqua , S. Turkcapar 

Centro Brasileiro de Pesquisas Fisicas, Rio de Janeiro, Brazil

G.A. Alves , M. Barroso Ferreira Filho , E. Coelho , C. Hensel , T. Menezes De Oliveira , C. Mora Herrera , P. Rebello Teles , M. Soeiro , E.J. Tonelli Manganote⁴ , A. Vilela Pereira⁵ 







Universidade do Estado do Rio de Janeiro, Rio de Janeiro, Brazil

W.L. Aldá Júnior , H. Brandao Malbouisson , W. Carvalho , J. Chinellato⁶ , M. Costa Reis , E.M. Da Costa , G.G. Da Silveira⁷ , D. De Jesus Damiao , S. Fonseca De Souza , R. Gomes De Souza , S. S. Jesus , T. Laux Kuhn⁷ , M. Macedo , K. Mota Amarilo , L. Mundim , H. Nogima , J.P. Pinheiro , A. Santoro , A. Sznajder , M. Thiel , F. Torres Da Silva De Araujo⁸ 





Universidade Estadual Paulista, Universidade Federal do ABC, São Paulo, Brazil

C.A. Bernardes⁷ , F. Damas , T.R. Fernandez Perez Tomei , E.M. Gregores , B. Lopes Da Costa , I. Maitetto Silverio , P.G. Mercadante , S.F. Novaes , B. Orzari , Sandra S. Padula , V. Scheurer



Institute for Nuclear Research and Nuclear Energy, Bulgarian Academy of Sciences, Sofia, Bulgaria

A. Aleksandrov , G. Antchev , P. Danev, R. Hadjiiska , P. Iaydjiev , M. Shopova , G. Sultanov 

University of Sofia, Sofia, Bulgaria

A. Dimitrov , L. Litov , B. Pavlov , P. Petkov , A. Petrov 

Instituto De Alta Investigación, Universidad de Tarapacá, Casilla 7 D, Arica, Chile

S. Keshri , D. Laroze , S. Thakur 

Universidad Tecnica Federico Santa Maria, Valparaiso, Chile

W. Brooks 















Beihang University, Beijing, China

T. Cheng , T. Javaid , L. Wang , L. Yuan 











Department of Physics, Tsinghua University, Beijing, China

Z. Hu , Z. Liang, J. Liu, X. Wang , H. Yang

Institute of High Energy Physics, Beijing, China

G.M. Chen⁹ , H.S. Chen⁹ , M. Chen⁹ , Y. Chen , Q. Hou , X. Hou, F. Iemmi , C.H. Jiang, A. Kapoor¹⁰ , H. Liao , G. Liu , Z.-A. Liu¹¹ , J.N. Song¹¹, S. Song , J. Tao , C. Wang⁹, J. Wang , H. Zhang , J. Zhao 

State Key Laboratory of Nuclear Physics and Technology, Peking University, Beijing, China

A. Agapitos , Y. Ban , A. Carvalho Antunes De Oliveira , S. Deng , B. Guo, Q. Guo, C. Jiang , A. Levin , C. Li , Q. Li , Y. Mao, S. Qian, S.J. Qian , X. Qin, C. Quaranta , X. Sun , D. Wang , J. Wang, M. Zhang, Y. Zhao, C. Zhou 

State Key Laboratory of Nuclear Physics and Technology, Institute of Quantum Matter, South China Normal University, Guangzhou, China

S. Yang 



Sun Yat-Sen University, Guangzhou, China

Z. You 

University of Science and Technology of China, Hefei, China

K. Jaffel , N. Lu 

Nanjing Normal University, Nanjing, China

G. Bauer^{12,13}, Z. Cui¹³, B. Li¹⁴, H. Wang , K. Yi¹⁵ , J. Zhang 



Institute of Modern Physics and Key Laboratory of Nuclear Physics and Ion-beam Application (MOE) - Fudan University, Shanghai, China

Y. Li, Y. Zhou¹⁶





Zhejiang University, Hangzhou, Zhejiang, China

Z. Lin , C. Lu , M. Xiao¹⁷ 



Universidad de Los Andes, Bogota, Colombia

C. Avila , D.A. Barbosa Trujillo , A. Cabrera , C. Florez , J. Fraga , J.A. Reyes Vega

Universidad de Antioquia, Medellin, Colombia

C. Rendón , M. Rodriguez , A.A. Ruales Barbosa , J.D. Ruiz Alvarez 

University of Split, Faculty of Electrical Engineering, Mechanical Engineering and Naval Architecture, Split, Croatia

N. Godinovic , D. Lelas , A. Sculac 

University of Split, Faculty of Science, Split, Croatia

M. Kovac , A. Petkovic , T. Sculac 

Institute Rudjer Boskovic, Zagreb, Croatia

P. Bargassa , V. Brigljevic , B.K. Chitroda , D. Ferencek , K. Jakovcic, A. Starodumov , T. Susa 

University of Cyprus, Nicosia, Cyprus

A. Attikis , K. Christoforou , C. Leonidou , C. Nicolaou, L. Paizanos , F. Ptochos , P.A. Razis , H. Rykaczewski, H. Saka , A. Stepennov 

Charles University, Prague, Czech Republic

M. Finger[†] , M. Finger Jr. 

Escuela Politecnica Nacional, Quito, Ecuador

E. Ayala 



Universidad San Francisco de Quito, Quito, Ecuador

E. Carrera Jarrin 







Academy of Scientific Research and Technology of the Arab Republic of Egypt, Egyptian Network of High Energy Physics, Cairo, Egypt

H. Abdalla¹⁸ , Y. Assran^{19,20}

Center for High Energy Physics (CHEP-FU), Fayoum University, El-Fayoum, Egypt

A. Hussein , H. Mohammed 















National Institute of Chemical Physics and Biophysics, Tallinn, Estonia

K. Ehataht , M. Kadastik, T. Lange , C. Nielsen , J. Pata , M. Raidal , N. Seeba , L. Tani 

Department of Physics, University of Helsinki, Helsinki, Finland

E. Brücken , A. Milieva , K. Osterberg , M. Voutilainen 





















Helsinki Institute of Physics, Helsinki, Finland

F. Garcia , P. Inkaew , K.T.S. Kallonen , R. Kumar Verma , T. Lampén , K. Lassila-Perini , B. Lehtela , S. Lehti , T. Lindén , N.R. Mancilla Xinto , M. Myllymäki , M.m. Rantanen , S. Saariokari , N.T. Toikka , J. Tuominiemi 

























Lappeenranta-Lahti University of Technology, Lappeenranta, Finland

N. Bin Norjoharuddeen , H. Kirschenmann , P. Luukka , H. Petrow 

IRFU, CEA, Université Paris-Saclay, Gif-sur-Yvette, France

M. Besancon , F. Couderc , M. Dejardin , D. Denegri, P. Devouge, J.L. Faure , F. Ferri , P. Gaigne, S. Ganjour , P. Gras , G. Hamel de Monchenault , M. Kumar , V. Lohezic , Y. Maidannyk , J. Malcles , F. Orlandi , L. Portales , S. Ronchi , M.Ö. Sahin , A. Savoy-Navarro²¹ , P. Simkina , M. Titov , M. Tornago 

Laboratoire Leprince-Ringuet, CNRS/IN2P3, Ecole Polytechnique, Institut Polytechnique de Paris, Palaiseau, France

R. Amella Ranz , F. Beaudette , G. Boldrini , P. Busson , C. Charlot , M. Chiusi , T.D. Cuisset , O. Davignon , A. De Wit , T. Debnath , I.T. Ehle , S. Ghosh , A. Gilbert , R. Granier de Cassagnac , L. Kalipoliti , M. Manoni , M. Nguyen , S. Obraztsov , C. Ochando , R. Salerno , J.B. Sauvan , Y. Sirois , G. Sokmen, L. Urda Gómez , A. Zabi , A. Zghiche 

Université de Strasbourg, CNRS, IPHC UMR 7178, Strasbourg, France





















J.-L. Agram²² , J. Andrea , D. Bloch , J.-M. Brom , E.C. Chabert , C. Collard , G. Coulon, S. Falke , U. Goerlach , R. Haeberle , A.-C. Le Bihan , M. Meena 

O. Poncet , G. Saha , P. Vaucelle 

Centre de Calcul de l'Institut National de Physique Nucleaire et de Physique des Particules, CNRS/IN2P3, Villeurbanne, France

A. Di Florio 

Institut de Physique des 2 Infinis de Lyon (IP2I), Villeurbanne, France

D. Amram , S. Beauceron , B. Blancon , G. Boudoul , N. Chanon , D. Contardo , P. Depasse , H. El Mamouni , J. Fay , S. Gascon , M. Gouzevitch , C. Greenberg , G. Grenier , B. Ille , E. Jourd'Huy , M. Lethuillier , B. Massoteau , L. Mirabito , A. Purohit , M. Vander Donckt , J. Xiao 































Georgian Technical University, Tbilisi, Georgia

D. Lomidze , I. Lomidze , Z. Tsamalaidze²³ 

RWTH Aachen University, I. Physikalisches Institut, Aachen, Germany

V. Botta , S. Consuegra Rodríguez , L. Feld , K. Klein , M. Lipinski , D. Meuser , P. Natland , V. Oppenländer , A. Pauls , D. Pérez Adán , N. Röwert , M. Teroerde 









































































RWTH Aachen University, III. Physikalisches Institut A, Aachen, Germany

C. Daumann , S. Diekmann , A. Dodonova , N. Eich , D. Eliseev , F. Engelke , J. Erdmann , M. Erdmann , B. Fischer , T. Hebbeker , K. Hoepfner , F. Ivone , A. Jung , N. Kumar , M.y. Lee , F. Mausolf , M. Merschmeyer , A. Meyer , F. Nowotny , A. Pozdnyakov , W. Redjeb , H. Reithler , U. Sarkar , V. Sarkisovi , A. Schmidt , C. Seth , A. Sharma , J.L. Spah , V. Vaulin , S. Zaleski 



































RWTH Aachen University, III. Physikalisches Institut B, Aachen, Germany

M.R. Beckers , C. Dziwok , G. Flügge , N. Hoeflich , T. Kress , A. Nowack , O. Pooth , A. Stahl , A. Zotz 

Deutsches Elektronen-Synchrotron, Hamburg, Germany









































H. Aarup Petersen , A. Abel , M. Aldaya Martin , J. Alimena , S. Amoroso , Y. An , I. Andreev , J. Bach , S. Baxter , M. Bayatmakou , H. Becerril Gonzalez , O. Behnke , A. Belvedere , F. Blekman²⁴ , K. Borrás²⁵ , A. Campbell , S. Chatterjee , L.X. Coll Saravia , G. Eckerlin , D. Eckstein , E. Gallo²⁴ , A. Geiser , V. Guglielmi , M. Guthoff , A. Hinzmann , L. Jeppe , M. Kasemann , C. Kleinwort , R. Kogler , M. Komm , D. Krücker , W. Lange , D. Leyva Pernia , K.-Y. Lin , K. Lipka²⁶ , W. Lohmann²⁷ , J. Malvaso , R. Mankel , I.-A. Melzer-Pellmann , M. Mendizabal Morentin , A.B. Meyer , G. Milella , K. Moral Figueroa , A. Mussgiller , L.P. Nair , J. Niedziela , A. Nürnberg , J. Park , E. Ranken , A. Raspereza , D. Rastorguev , L. Rygaard , M. Scham^{28,25} , S. Schnake²⁵ , P. Schütze , C. Schwanenberger²⁴ , D. Selivanova , K. Sharko , M. Shchedrolosiev , D. Stafford , M. Torkian , F. Vazzoler , A. Ventura Barroso , R. Walsh , D. Wang , Q. Wang , K. Wichmann , L. Wiens²⁵ , C. Wissing , Y. Yang , S. Zakharov , A. Zimmermann Castro Santos 

University of Hamburg, Hamburg, Germany

A.R. Alves Andrade , M. Antonello , S. Bollweg , M. Bonanomi , K. El Morabit , Y. Fischer , M. Frahm , E. Garutti , A. Grohsjean , A.A. Guvenli , J. Haller , D. Hundhausen , G. Kasieczka , P. Keicher , R. Klanner , W. Korcari , T. Kramer , C.c. Kuo , F. Labe , J. Lange , A. Lobanov , L. Moureaux , A. Nigamova , K. Nikolopoulos , A. Paasch , K.J. Pena Rodriguez , N. Prouvost , B. Raciti , M. Rieger , D. Savoiu , P. Schleper , M. Schröder , J. Schwandt , M. Sommerhalder , H. Stadie 

G. Steinbrück , R. Ward , B. Wiederspan, M. Wolf 









Karlsruher Institut fuer Technologie, Karlsruhe, Germany

S. Brommer , E. Butz , Y.M. Chen , T. Chwalek , A. Dierlamm , G.G. Dincer , U. Elicabuk, N. Faltermann , M. Giffels , A. Gottmann , F. Hartmann²⁹ , M. Horzela , F. Hummer , U. Husemann , J. Kieseler , M. Klute , R. Kunnilan Muhammed Rafeek, O. Lavoryk , J.M. Lawhorn , A. Lintuluoto , S. Maier , M. Mormile , Th. Müller , E. Pfeffer , M. Presilla , G. Quast , K. Rabbertz , B. Regnery , R. Schmieder, N. Shadskiy , I. Shvetsov , H.J. Simonis , L. Sowa , L. Stockmeier, K. Tauqeer, M. Toms , B. Topko , N. Trevisani , C. Verstege , T. Voigtländer , R.F. Von Cube , J. Von Den Driesch, M. Wassmer , R. Wolf , W.D. Zeuner , X. Zuo 





Institute of Nuclear and Particle Physics (INPP), NCSR Demokritos, Aghia Paraskevi, Greece

G. Anagnostou , G. Daskalakis , A. Kyriakis 







National and Kapodistrian University of Athens, Athens, Greece

G. Melachroinos, Z. Painesis , I. Paraskevas , N. Saoulidou , K. Theofilatos , E. Tziaferi , E. Tzovara , K. Vellidis , I. Zisopoulos 







National Technical University of Athens, Athens, Greece

T. Chatzistavrou , G. Karapostoli , K. Kousouris , E. Siamarkou, G. Tsipolitis 

University of Ioánnina, Ioánnina, Greece

I. Bestintzanos, I. Evangelou , C. Foudas, P. Katsoulis, P. Kokkas , P.G. Kosmoglou Kioseoglou , N. Manthos , I. Papadopoulos , J. Strologas 

HUN-REN Wigner Research Centre for Physics, Budapest, Hungary

D. Druzhkin , C. Hajdu , D. Horvath^{30,31} , K. Márton, A.J. Rádl³² , F. Sikler , V. Veszpremi 

MTA-ELTE Lendület CMS Particle and Nuclear Physics Group, Eötvös Loránd University, Budapest, Hungary

M. Csanád , K. Farkas , A. Fehérkuti³³ , M.M.A. Gadallah³⁴ , Á. Kadlecik , M. León Coello , G. Pásztor , G.I. Veres 

Faculty of Informatics, University of Debrecen, Debrecen, Hungary

B. Ujvari , G. Zilizi 













HUN-REN ATOMKI - Institute of Nuclear Research, Debrecen, Hungary

G. Bencze, S. Czellar, J. Molnar, Z. Szillasi

Karoly Robert Campus, MATE Institute of Technology, Gyongyos, Hungary

T. Csorgo³³ , F. Nemes³³ , T. Novak , I. Szanyi³⁵ 

Panjab University, Chandigarh, India









S. Bansal , S.B. Beri, V. Bhatnagar , G. Chaudhary , S. Chauhan , N. Dhingra³⁶ , A. Kaur , A. Kaur , H. Kaur , M. Kaur , S. Kumar , T. Sheokand, J.B. Singh , A. Singla 

University of Delhi, Delhi, India



































































A. Bhardwaj , A. Chhetri , B.C. Choudhary , A. Kumar , A. Kumar , M. Naimuddin , S. Phor , K. Ranjan , M.K. Saini

Indian Institute of Technology Mandi (IIT-Mandi), Himachal Pradesh, India



























P. Palni 

University of Hyderabad, Hyderabad, IndiaS. Acharya³⁷ , B. Gomber **Indian Institute of Technology Kanpur, Kanpur, India**S. Mukherjee **Saha Institute of Nuclear Physics, HBNI, Kolkata, India**S. Bhattacharya , S. Das Gupta, S. Dutta , S. Dutta, S. Sarkar**Indian Institute of Technology Madras, Madras, India**M.M. Ameen , P.K. Behera , S. Chatterjee , G. Dash , A. Dattamunsi, P. Jana , P. Kalbhor , S. Kamble , J.R. Komaragiri³⁸ , T. Mishra , P.R. Pujahari , A.K. Sikdar , R.K. Singh , P. Verma , S. Verma , A. Vijay **IISER Mohali, India, Mohali, India**





B.K. Sirasva

Tata Institute of Fundamental Research-A, Mumbai, IndiaL. Bhatt, S. Dugad , G.B. Mohanty , M. Shelake , P. Suryadevara**Tata Institute of Fundamental Research-B, Mumbai, India**A. Bala , S. Banerjee , S. Barman³⁹ , R.M. Chatterjee, M. Guchait , Sh. Jain , A. Jaiswal, B.M. Joshi , S. Kumar , M. Maity³⁹, G. Majumder , K. Mazumdar , S. Parolia , R. Saxena , A. Thachayath **National Institute of Science Education and Research, An OCC of Homi Bhabha National Institute, Bhubaneswar, Odisha, India**S. Bahinipati⁴⁰ , D. Maity⁴¹ , P. Mal , K. Naskar⁴¹ , A. Nayak⁴¹ , S. Nayak , K. Pal , R. Raturi, P. Sadangi, S.K. Swain , S. Varghese⁴¹ , D. Vats⁴¹ **Indian Institute of Science Education and Research (IISER), Pune, India**A. Alpana , S. Dube , P. Hazarika , B. Kansal , A. Laha , R. Sharma , S. Sharma , K.Y. Vaish **Indian Institute of Technology Hyderabad, Telangana, India**S. Ghosh **Isfahan University of Technology, Isfahan, Iran**H. Bakhshiansohi⁴² , A. Jafari⁴³ , V. Sedighzadeh Dalavi , M. Zeinali⁴⁴ **Institute for Research in Fundamental Sciences (IPM), Tehran, Iran**S. Bashiri , S. Chenarani⁴⁵ , S.M. Etesami , Y. Hosseini , M. Khakzad , E. Khazaie , M. Mohammadi Najafabadi , S. Tizchang⁴⁶ **University College Dublin, Dublin, Ireland**M. Felcini , M. Grunewald **INFN Sezione di Bari^a, Università di Bari^b, Politecnico di Bari^c, Bari, Italy**M. Abbrescia^{a,b} , M. Barbieri^{a,b}, M. Buonsante^{a,b} , A. Colaleo^{a,b} , D. Creanza^{a,c} , N. De Filippis^{a,c} , M. De Palma^{a,b} , W. Elmetenawee^{a,b,47} , N. Ferrara^{a,c} , L. Fiore^a , L. Longo^a , M. Louka^{a,b} , G. Maggi^{a,c} , M. Maggi^a , I. Margjeka^a , V. Mastrapasqua^{a,b} , S. My^{a,b} , F. Nenna^{a,b} , S. Nuzzo^{a,b} , A. Pellecchia^{a,b} , A. Pompili^{a,b} , G. Pugliese^{a,c} , R. Radogna^{a,b} , D. Ramos^a , A. Ranieri^a , L. Silvestris^a , F.M. Simone^{a,c} , Ü. Sözbilir^a , A. Stamerra^{a,b} , D. Troiano^{a,b} , R. Venditti^{a,b} , P. Verwilligen^a , A. Zaza^{a,b} 





















INFN Sezione di Bologna^a, Università di Bologna^b, Bologna, Italy

G. Abbiendi^a , C. Battilana^{a,b} , D. Bonacorsi^{a,b} , P. Capiluppi^{a,b} , F.R. Cavallo^a , G.M. Dallavalle^a , T. Diotallevi^{a,b} , F. Fabbri^a , A. Fanfani^{a,b} , R. Farinelli^a , D. Fasanella^a , P. Giacomelli^a , C. Grandi^a , L. Guiducci^{a,b} , S. Lo Meo^{a,48} , M. Lorusso^{a,b} , L. Lunerti^a , G. Masetti^a , F.L. Navarra^{a,b} , G. Paggi^{a,b} , A. Perrotta^a , F. Primavera^{a,b} , A.M. Rossi^{a,b} , S. Rossi Tisbeni^{a,b} , T. Rovelli^{a,b} , G.P. Siroli^{a,b} 





INFN Sezione di Catania^a, Università di Catania^b, Catania, Italy

S. Costa^{a,b,49} , A. Di Mattia^a , A. Lapertosa^a , R. Potenza^{a,b}, A. Tricomi^{a,b,49} 

INFN Sezione di Firenze^a, Università di Firenze^b, Firenze, Italy

J. Altork^{a,b} , P. Assiouras^a , G. Barbagli^a , G. Bardelli^a , M. Bartolini^{a,b} , A. Calandri^{a,b} , B. Camaiani^{a,b} , A. Cassese^a , R. Ceccarelli^a , V. Ciulli^{a,b} , C. Civinini^a , R. D'Alessandro^{a,b} , L. Damenti^{a,b}, E. Focardi^{a,b} , T. Kello^a , G. Latino^{a,b} , P. Lenzi^{a,b} , M. Lizzo^a , M. Meschini^a , S. Paoletti^a , A. Papanastassiou^{a,b}, G. Sguazzoni^a , L. Viliani^a 

























INFN Laboratori Nazionali di Frascati, Frascati, Italy

L. Benussi , S. Colafranceschi⁵⁰ , S. Meola⁵¹ , D. Piccolo 









INFN Sezione di Genova^a, Università di Genova^b, Genova, Italy

M. Alves Gallo Pereira^a , F. Ferro^a , E. Robutti^a , S. Tosi^{a,b} 

























INFN Sezione di Milano-Bicocca^a, Università di Milano-Bicocca^b, Milano, Italy

A. Benaglia^a , F. Brivio^a , V. Camagni^{a,b} , F. Cetorelli^{a,b} , F. De Guio^{a,b} , M.E. Dinardo^{a,b} , P. Dini^a , S. Gennai^a , R. Gerosa^{a,b} , A. Ghezzi^{a,b} , P. Govoni^{a,b} , L. Guzzi^a , M.R. Kim^a , G. Lavizzari^{a,b}, M.T. Lucchini^{a,b} , M. Malberti^a , S. Malvezzi^a , A. Massironi^a , D. Menasce^a , L. Moroni^a , M. Paganoni^{a,b} , S. Palluotto^{a,b} , D. Pedrini^a , A. Perego^{a,b} , G. Pizzati^{a,b} , T. Tabarelli de Fatis^{a,b} 









INFN Sezione di Napoli^a, Università di Napoli 'Federico II'^b, Napoli, Italy; Università della Basilicata^c, Potenza, Italy; Scuola Superiore Meridionale (SSM)^d, Napoli, Italy

S. Buontempo^a , C. Di Fraia^{a,b} , F. Fabozzi^{a,c} , L. Favilla^{a,d} , A.O.M. Iorio^{a,b} , L. Lista^{a,b,52} , P. Paolucci^{a,29} , B. Rossi^a 











INFN Sezione di Padova^a, Università di Padova^b, Padova, Italy; Università degli Studi di Cagliari^c, Cagliari, Italy

P. Azzi^a , N. Bacchetta^{a,53} , D. Bisello^{a,b} , P. Bortignon^{a,c} , G. Bortolato^{a,b} , A.C.M. Bulla^{a,c} , R. Carlin^{a,b} , P. Checchia^a , T. Dorigo^{a,54} , U. Gasparini^{a,b} , S. Giorgetti^a , A. Gozzelino^a , E. Lusiani^a , M. Margoni^{a,b} , A.T. Meneguzzo^{a,b} , J. Pazzini^{a,b} , P. Ronchese^{a,b} , R. Rossin^{a,b} , F. Simonetto^{a,b} , M. Tosi^{a,b} , A. Triossi^{a,b} , M. Zanetti^{a,b} , P. Zotto^{a,b} , A. Zucchetta^{a,b} , G. Zumerle^{a,b} 

INFN Sezione di Pavia^a, Università di Pavia^b, Pavia, Italy







S. Abu Zeid^{a,55} , A. Braghieri^a , S. Calzaferri^{a,b} , P. Montagna^{a,b} , M. Pelliccioni^{a,b} , V. Re^a , C. Riccardi^{a,b} , I. Vai^{a,b} , P. Vitulo^{a,b} 

INFN Sezione di Perugia^a, Università di Perugia^b, Perugia, Italy







S. Ajmal^{a,b} , M.E. Ascoti^{a,b}, G.M. Bilei^a , C. Carrivale^{a,b}, D. Ciangottini^{a,b} , L. Della Penna^{a,b}, L. Fanò^{a,b} , V. Mariani^{a,b} , M. Menichelli^a , F. Moscatelli^{a,56} , A. Rossi^{a,b} , A. Santocchia^{a,b} , D. Spiga^a , T. Tedeschi^{a,b} 

INFN Sezione di Pisa^a, Università di Pisa^b, Scuola Normale Superiore di Pisa^c, Pisa, Italy;







Università di Siena^d, Siena, Italy

C. Aimè^{a,b} , C.A. Alexe^{a,c} , P. Asenov^{a,b} , P. Azzurri^a , G. Bagliesi^a , L. Bianchini^{a,b} , T. Boccali^a , E. Bossini^a , D. Bruschini^{a,c} , L. Calligaris^{a,b} , R. Castaldi^a , F. Cattafesta^{a,c} , M.A. Ciocci^{a,d} , M. Cipriani^{a,b} , R. Dell'Orso^a , S. Donato^{a,b} , R. Forti^{a,b} , A. Giassi^a , F. Ligabue^{a,c} , A.C. Marini^{a,b} , D. Matos Figueiredo^a , A. Messineo^{a,b} , S. Mishra^a , V.K. Muraleedharan Nair Bindhu^{a,b} , S. Nandan^a , F. Palla^a , M. Riggirello^{a,c} , A. Rizzi^{a,b} , G. Rolandi^{a,c} , S. Roy Chowdhury^{a,57} , T. Sarkar^a , A. Scribano^a , P. Solanki^{a,b} , P. Spagnolo^a , F. Tenchini^{a,b} , R. Tenchini^a , G. Tonelli^{a,b} , N. Turini^{a,d} , F. Vaselli^{a,c} , A. Venturi^a , P.G. Verdini^a

INFN Sezione di Roma^a, Sapienza Università di Roma^b, Roma, Italy

P. Akrap^{a,b} , C. Basile^{a,b} , S.C. Behera^a , F. Cavallari^a , L. Cunqueiro Mendez^{a,b} , F. De Ruggi^{a,b} , D. Del Re^{a,b} , E. Di Marco^a , M. Diemoz^a , F. Errico^a , L. Frosina^{a,b} , R. Gargiulo^{a,b} , B. Harikrishnan^{a,b} , F. Lombardi^{a,b} , E. Longo^{a,b} , L. Martikainen^{a,b} , J. Mijuskovic^{a,b} , G. Organtini^{a,b} , N. Palmeri^{a,b} , R. Paramatti^{a,b} , S. Rahatlou^{a,b} , C. Rovelli^a , F. Santanastasio^{a,b} , L. Soffi^a , V. Vladimirov^{a,b}

INFN Sezione di Torino^a, Università di Torino^b, Torino, Italy; Università del Piemonte Orientale^c, Novara, Italy

N. Amapane^{a,b} , R. Arcidiacono^{a,c} , S. Argiro^{a,b} , M. Arneodo^{a,c} , N. Bartosik^{a,c} , R. Bellan^{a,b} , A. Bellora^{a,b} , C. Biino^a , C. Borca^{a,b} , N. Cartiglia^a , M. Costa^{a,b} , R. Covarelli^{a,b} , N. Demaria^a , L. Finco^a , M. Grippo^{a,b} , B. Kiani^{a,b} , L. Lanteri^{a,b} , F. Legger^a , F. Luongo^{a,b} , C. Mariotti^a , S. Maselli^a , A. Mecca^{a,b} , L. Menzio^{a,b} , P. Meridiani^a , E. Migliore^{a,b} , M. Monteno^a , M.M. Obertino^{a,b} , G. Ortona^a , L. Pacher^{a,b} , N. Pastrone^a , M. Ruspá^{a,c} , F. Siviero^{a,b} , V. Sola^{a,b} , A. Solano^{a,b} , A. Staiano^a , C. Tarricone^{a,b} , D. Trocino^a , G. Umoret^{a,b} , E. Vlasov^{a,b} , R. White^{a,b}

INFN Sezione di Trieste^a, Università di Trieste^b, Trieste, Italy

J. Babbar^{a,b} , S. Belforte^a , V. Candelise^{a,b} , M. Casarsa^a , F. Cossutti^a , K. De Leo^a , G. Della Ricca^{a,b} , R. Delli Gatti^{a,b}

Kyungpook National University, Daegu, Korea

S. Dogra , J. Hong , J. Kim , T. Kim , D. Lee , H. Lee , J. Lee , S.W. Lee , C.S. Moon , Y.D. Oh , S. Sekmen , B. Tae , Y.C. Yang



Department of Mathematics and Physics - GWNu, Gangneung, Korea

M.S. Kim 

Chonnam National University, Institute for Universe and Elementary Particles, Kwangju, Korea

G. Bak , P. Gwak , H. Kim , D.H. Moon , J. Seo 

Hanyang University, Seoul, Korea

E. Asilar , F. Carnevali , J. Choi⁵⁸ , T.J. Kim , Y. Ryou 

Korea University, Seoul, Korea

S. Ha , S. Han , B. Hong , J. Kim , K. Lee , K.S. Lee , S. Lee , J. Yoo

Kyung Hee University, Department of Physics, Seoul, Korea

J. Goh , J. Shin , S. Yang 







Sejong University, Seoul, Korea

Y. Kang , H. S. Kim , Y. Kim , S. Lee 

Seoul National University, Seoul, Korea

J. Almond, J.H. Bhyun, J. Choi , J. Choi, W. Jun , H. Kim , J. Kim , T. Kim, Y. Kim , Y.W. Kim , S. Ko , H. Lee , J. Lee , J. Lee , B.H. Oh , S.B. Oh , J. Shin , U.K. Yang, I. Yoon 

University of Seoul, Seoul, Korea

W. Jang , D.Y. Kang, D. Kim , S. Kim , B. Ko, J.S.H. Lee , Y. Lee , I.C. Park , Y. Roh, I.J. Watson 

Yonsei University, Department of Physics, Seoul, Korea

G. Cho, K. Hwang , B. Kim , S. Kim, K. Lee , H.D. Yoo 

Sungkyunkwan University, Suwon, Korea

Y. Lee , I. Yu 

College of Engineering and Technology, American University of the Middle East (AUM), Dasman, Kuwait

T. Beyrouthy , Y. Gharbia 

Kuwait University - College of Science - Department of Physics, Safat, Kuwait

F. Alazemi 



Riga Technical University, Riga, Latvia

K. Dreimanis , O.M. Eberlins , A. Gaile , C. Munoz Diaz , D. Osite , G. Pikurs , R. Plese , A. Potrebko , M. Seidel , D. Sidiropoulos Kontos 

University of Latvia (LU), Riga, Latvia

N.R. Strautnieks 

Vilnius University, Vilnius, Lithuania

M. Ambrozas , A. Juodagalvis , S. Nargelas , A. Rinkevicius , G. Tamulaitis 







National Centre for Particle Physics, Universiti Malaya, Kuala Lumpur, Malaysia

I. Yusuff⁵⁹ , Z. Zolkapli

Universidad de Sonora (UNISON), Hermosillo, Mexico

J.F. Benitez , A. Castaneda Hernandez , A. Cota Rodriguez , L.E. Cuevas Picos, H.A. Encinas Acosta, L.G. Gallegos Maríñez, J.A. Murillo Quijada , L. Valencia Palomo 

Centro de Investigacion y de Estudios Avanzados del IPN, Mexico City, Mexico

G. Ayala , H. Castilla-Valdez , H. Crotte Ledesma , R. Lopez-Fernandez , J. Mejia Guisao , R. Reyes-Almanza , A. Sánchez Hernández 

Universidad Iberoamericana, Mexico City, Mexico

C. Oropeza Barrera , D.L. Ramirez Guadarrama, M. Ramírez García 

Benemerita Universidad Autonoma de Puebla, Puebla, Mexico

I. Bautista , F.E. Neri Huerta , I. Pedraza , H.A. Salazar Ibarguen , C. Uribe Estrada 





University of Montenegro, Podgorica, Montenegro

I. Bujanja , N. Raicevic 

University of Canterbury, Christchurch, New Zealand

P.H. Butler 

National Centre for Physics, Quaid-I-Azam University, Islamabad, Pakistan

A. Ahmad , M.I. Asghar , A. Awais , M.I.M. Awan, W.A. Khan 







AGH University of Krakow, Krakow, Poland

V. Avati, L. Forthomme , L. Grzanka , M. Malawski , K. Piotrkowski 

National Centre for Nuclear Research, Swierk, Poland

M. Bluj , M. Górski , M. Kazana , M. Szleper , P. Zalewski 

















Institute of Experimental Physics, Faculty of Physics, University of Warsaw, Warsaw, Poland

K. Bunkowski , K. Doroba , A. Kalinowski , M. Konecki , J. Krolikowski , A. Muhammad 





Warsaw University of Technology, Warsaw, Poland

P. Fokow , K. Pozniak , W. Zabolotny 

Laboratório de Instrumentação e Física Experimental de Partículas, Lisboa, Portugal

M. Araujo , D. Bastos , C. Beirão Da Cruz E Silva , A. Boletti , M. Bozzo , T. Camporesi , G. Da Molin , M. Gallinaro , J. Hollar , N. Leonardo , G.B. Marozzo , A. Petrilli , M. Pisano , J. Seixas , J. Varela , J.W. Wulff 

































Faculty of Physics, University of Belgrade, Belgrade, Serbia

P. Adzic , L. Markovic , P. Milenovic , V. Milosevic 

VINCA Institute of Nuclear Sciences, University of Belgrade, Belgrade, Serbia

D. Devetak , M. Dordevic , J. Milosevic , L. Nadderd , V. Rekovic, M. Stojanovic 















Centro de Investigaciones Energéticas Medioambientales y Tecnológicas (CIEMAT), Madrid, Spain

M. Alcalde Martinez , J. Alcaraz Maestre , Cristina F. Bedoya , J.A. Brochero Cifuentes , Oliver M. Carretero , M. Cepeda , M. Cerrada , N. Colino , B. De La Cruz , A. Delgado Peris , A. Escalante Del Valle , D. Fernández Del Val , J.P. Fernández Ramos , J. Flix , M.C. Fouz , M. Gonzalez Hernandez , O. Gonzalez Lopez , S. Goy Lopez , J.M. Hernandez , M.I. Josa , J. Llorente Merino , C. Martin Perez , E. Martin Viscasillas , D. Moran , C. M. Morcillo Perez , Á. Navarro Tobar , R. Paz Herrera , C. Perez Dengra , A. Pérez-Calero Yzquierdo , J. Puerta Pelayo , I. Redondo , J. Vazquez Escobar 



















Universidad Autónoma de Madrid, Madrid, Spain

J.F. de Trocóniz 

Universidad de Oviedo, Instituto Universitario de Ciencias y Tecnologías Espaciales de Asturias (ICTEA), Oviedo, Spain

B. Alvarez Gonzalez , J. Ayllon Torresano , A. Cardini , J. Cuevas , J. Del Riego Badas , D. Estrada Acevedo , J. Fernandez Menendez , S. Folgueras , I. Gonzalez Caballero , P. Leguina , M. Obeso Menendez , E. Palencia Cortezon , J. Prado Pico , A. Soto Rodríguez , P. Vischia 

Instituto de Física de Cantabria (IFCA), CSIC-Universidad de Cantabria, Santander, Spain

S. Blanco Fernández , I.J. Cabrillo , A. Calderon , J. Duarte Campderros , M. Fernandez , G. Gomez , C. Lasaosa García , R. Lopez Ruiz , C. Martinez Rivero , P. Martinez Ruiz del Arbol , F. Matorras , P. Matorras Cuevas , E. Navarrete Ramos , J. Piedra Gomez , C. Quintana San Emeterio , L. Scodellaro , I. Vila , R. Villar Cortabitarte , J.M. Vizan Garcia 





University of Colombo, Colombo, Sri Lanka

B. Kailasapathy⁶⁰ , D.D.C. Wickramarathna 













University of Ruhuna, Department of Physics, Matara, Sri Lanka

W.G.D. Dharmaratna⁶¹ , K. Liyanage , N. Perera 





























CERN, European Organization for Nuclear Research, Geneva, Switzerland

D. Abbaneo , C. Amendola , R. Ardino , E. Auffray , J. Baechler, D. Barney , J. Bendauid , M. Bianco , A. Bocci , L. Borgonovi , C. Botta , A. Bragagnolo , C.E. Brown , C. Caillol , G. Cerminara , P. Connor , D. d'Enterria , A. Dabrowski , A. David , A. De Roeck , M.M. Defranchis , M. Deile , M. Dobson , P.J. Fernández Manteca , B.A. Fontana Santos Alves , E. Fontanesi , W. Funk , A. Gaddi, S. Giani, D. Gigi, K. Gill , F. Glege , M. Glowacki, A. Gruber , J. Hegeman , J.K. Heikkilä , R. Hofsaess , B. Huber , T. James , P. Janot , O. Kaluzinska , O. Karacheban²⁷ , G. Karathanasis , S. Laurila , P. Lecoq , E. Leutgeb , C. Lourenço , A.-M. Lyon , M. Magherini , L. Malgeri , M. Mannelli , A. Mehta , F. Meijers , J.A. Merlin, S. Mersi , E. Meschi , M. Migliorini , F. Monti , F. Moortgat , M. Mulders , M. Musich , I. Neutelings , S. Orfanelli, F. Pantaleo , M. Pari , G. Petrucciani , A. Pfeiffer , M. Pierini , M. Pitt , H. Qu , D. Rabady , A. Reimers , B. Ribeiro Lopes , F. Riti , P. Rosado , M. Rovere , H. Sakulin , R. Salvatico , S. Sanchez Cruz , S. Scarfi , M. Selvaggi , A. Sharma , K. Shchelina , P. Silva , P. Sphicas⁶² , A.G. Stahl Leiton , A. Steen , S. Summers , D. Treille , P. Tropea , E. Vernazza , J. Wanczyk⁶³ , S. Wuchterl , M. Zarucki , P. Zehetner , P. Zejd , G. Zevi Della Porta 



PSI Center for Neutron and Muon Sciences, Villigen, Switzerland

T. Bevilacqua⁶⁴ , L. Caminada⁶⁴ , W. Erdmann , R. Horisberger , Q. Ingram , H.C. Kaestli , D. Kotlinski , C. Lange , U. Langenegger , L. Noehte⁶⁴ , T. Rohe , A. Samalan 

ETH Zurich - Institute for Particle Physics and Astrophysics (IPA), Zurich, Switzerland

T.K. Aarrestad , M. Backhaus , G. Bonomelli , C. Cazzaniga , K. Datta , P. De Bryas Dexmiers D'Archiacchiac⁶³ , A. De Cosa , G. Dissertori , M. Dittmar, M. Donegà , F. Eble , K. Gedia , F. Glessgen , C. Grab , N. Härringer , T.G. Harte , W. Lustermann , M. Malucchi , R.A. Manzoni , L. Marchese , A. Mascellani⁶³ , F. Nessi-Tedaldi , F. Pauss , V. Perovic , B. Ristic , R. Seidita , J. Steggemann⁶³ , A. Tarabini , D. Valsecchi , R. Wallny 













Universität Zürich, Zurich, Switzerland

C. Amsler⁶⁵ , P. Bäertschi , F. Bilandzija , M.F. Canelli , G. Celotto , K. Cormier , M. Huwiler , W. Jin , A. Jofrehei , B. Kilminster , T.H. Kwok , S. Leontsinis , V. Lukashenko , A. Macchiolo , F. Meng , M. Missiroli , J. Motta , P. Robmann, M. Senger , E. Shokr , F. Stäger , R. Tramontano , P. Viscone 

National Central University, Chung-Li, Taiwan

D. Bhowmik, C.M. Kuo, P.K. Rout , S. Taj , P.C. Tiwari³⁸ 

National Taiwan University (NTU), Taipei, Taiwan

L. Ceard, K.F. Chen , Z.g. Chen, A. De Iorio , W.-S. Hou , T.h. Hsu, Y.w. Kao, S. Karmakar , G. Kole , Y.y. Li , R.-S. Lu , E. Paganis , X.f. Su , J. Thomas-Wilsker , L.s. Tsai, D. Tzionou, H.y. Wu , E. Yazgan 















High Energy Physics Research Unit, Department of Physics, Faculty of Science, Chulalongkorn University, Bangkok, Thailand

C. Asawatangtrakuldee , N. Srimanobhas 

Tunis El Manar University, Tunis, Tunisia

Y. Maghrbi 

Çukurova University, Physics Department, Science and Art Faculty, Adana, Turkey

D. Agyel , F. Dolek , I. Dumanoglu⁶⁶ , Y. Guler⁶⁷ , E. Gurpinar Guler⁶⁷ , C. Isik ,
O. Kara , A. Kayis Topaksu , Y. Komurcu , G. Onengut , K. Ozdemir⁶⁸ , B. Tali⁶⁹ ,
U.G. Tok , E. Uslan , I.S. Zorbakir 

Hacettepe University, Ankara, Turkey

S. Sen 

Middle East Technical University, Physics Department, Ankara, Turkey

M. Yalvac⁷⁰ 

Bogazici University, Istanbul, Turkey

B. Akgun , I.O. Atakisi⁷¹ , E. Gülmez , M. Kaya⁷² , O. Kaya⁷³ , M.A. Sarkisla⁷⁴,
S. Tekten⁷⁵ 







Istanbul Technical University, Istanbul, Turkey

D. Boncukcu , A. Cakir , K. Cankocak^{66,76} 

Istanbul University, Istanbul, Turkey

B. Hacisahinoglu , I. Hos⁷⁷ , B. Kaynak , S. Ozkorucuklu , O. Potok , H. Sert ,
C. Simsek , C. Zorbilmez 

Yildiz Technical University, Istanbul, Turkey

S. Cerci , C. Dozen⁷⁸ , B. Isildak⁷⁹ , E. Simsek , D. Sunar Cerci , T. Yetkin⁷⁸ 













Institute for Scintillation Materials of National Academy of Science of Ukraine, Kharkiv, Ukraine

A. Boyaryntsev , O. Dadazhanova, B. Grynyov 





















National Science Centre, Kharkiv Institute of Physics and Technology, Kharkiv, Ukraine

L. Levchuk 









































University of Bristol, Bristol, United Kingdom

J.J. Brooke , A. Bundock , F. Bury , E. Clement , D. Cussans , D. Dharmender,
H. Flacher , J. Goldstein , H.F. Heath , M.-L. Holmberg , L. Kreczko , S. Parames-
varan , L. Robertshaw , M.S. Sanjrani⁴², J. Segal, V.J. Smith 



Rutherford Appleton Laboratory, Didcot, United Kingdom

A.H. Ball, K.W. Bell , A. Belyaev⁸⁰ , C. Brew , R.M. Brown , D.J.A. Cockerill ,
A. Elliot , K.V. Ellis, J. Gajownik , K. Harder , S. Harper , J. Linacre , K. Manolopoulos,
M. Moallemi , D.M. Newbold , E. Olaiya , D. Petyt , T. Reis , A.R. Sahasransu ,
G. Salvi , T. Schuh, C.H. Shepherd-Themistocleous , I.R. Tomalin , K.C. Whalen ,
T. Williams 













Imperial College, London, United Kingdom

I. Andreou , R. Bainbridge , P. Bloch , O. Buchmuller, C.A. Carrillo Montoya ,
D. Colling , I. Das , P. Dauncey , G. Davies , M. Della Negra , S. Fayer, G. Fedi ,
G. Hall , H.R. Hoorani , A. Howard, G. Iles , C.R. Knight , P. Krueper , J. Langford ,
K.H. Law , J. León Holgado , L. Lyons , A.-M. Magnan , B. Maier , S. Mallios ,
A. Mastronikolis , M. Mieskolainen , J. Nash⁸¹ , M. Pesaresi , P.B. Pradeep ,
B.C. Radburn-Smith , A. Richards, A. Rose , L. Russell , K. Savva , C. Seez ,
R. Shukla , A. Tapper , K. Uchida , G.P. Uttley , T. Virdee²⁹ , M. Vojinovic ,
N. Wardle , D. Winterbottom 

Brunel University, Uxbridge, United Kingdom

J.E. Cole , A. Khan, P. Kyberd , I.D. Reid 

Baylor University, Waco, Texas, USA

S. Abdullin , A. Brinkerhoff , E. Collins , M.R. Darwish , J. Dittmann , K. Hatakeyama , V. Hegde , J. Hiltbrand , B. McMaster , J. Samudio , S. Sawant , C. Sutantawibul , J. Wilson 













Bethel University, St. Paul, Minnesota, USA

J.M. Hogan 

















Catholic University of America, Washington, DC, USA

R. Bartek , A. Dominguez , S. Raj , B. Sahu³⁷ , A.E. Simsek , S.S. Yu 



















The University of Alabama, Tuscaloosa, Alabama, USA

B. Bam , A. Buchot Perraguin , S. Campbell, R. Chudasama , S.I. Cooper , C. Crovella , G. Fidalgo , S.V. Gleyzer , A. Khukhunaishvili , K. Matchev , E. Pearson, C.U. Perez , P. Rumerio⁸² , E. Usai , R. Yi 

















Boston University, Boston, Massachusetts, USA

S. Cholak , G. De Castro, Z. Demiragli , C. Erice , C. Fangmeier , C. Fernandez Madrazo , J. Fulcher , F. Golf , S. Jeon , J. O’Cain, I. Reed , J. Rohlf , K. Salyer , D. Sperka , D. Spitzbart , I. Suarez , A. Tsatsos , E. Wurtz, A.G. Zecchinelli 















Brown University, Providence, Rhode Island, USA

G. Barone , G. Benelli , D. Cutts , S. Ellis , L. Gouskos , M. Hadley , U. Heintz , K.W. Ho , T. Kwon , L. Lambrecht , G. Landsberg , K.T. Lau , J. Luo , S. Mondal , J. Roloff, T. Russell , S. Sagir⁸³ , X. Shen , M. Stamenkovic , N. Venkatasubramanian 



University of California, Davis, Davis, California, USA

S. Abbott , S. Baradia , B. Barton , R. Breedon , H. Cai , M. Calderon De La Barca Sanchez , E. Cannaert, M. Chertok , M. Citron , J. Conway , P.T. Cox , R. Erbacher , O. Kukral , G. Mocellin , S. Ostrom , I. Salazar Segovia, J.S. Tafoya Vargas , W. Wei , S. Yoo 

























University of California, Los Angeles, California, USA

K. Adamidis, M. Bachtis , D. Campos, R. Cousins , S. Crossley , A. Datta , G. Flores Avila , J. Hauser , M. Ignatenko , M.A. Iqbal , T. Lam , Y.f. Lo , E. Manca , A. Nunez Del Prado , D. Saltzberg , V. Valuev 



















University of California, Riverside, Riverside, California, USA

R. Clare , J.W. Gary , G. Hanson 











University of California, San Diego, La Jolla, California, USA

A. Aportela , A. Arora , J.G. Branson , S. Cittolin , S. Cooperstein , B. D’Anzi , D. Diaz , J. Duarte , L. Giannini , Y. Gu, J. Guiang , V. Krutelyov , R. Lee , J. Letts , H. Li, M. Masciovecchio , F. Mokhtar , S. Mukherjee , M. Pieri , D. Primosch, M. Quinnan , V. Sharma , M. Tadel , E. Vourliotis , F. Würthwein , A. Yagil , Z. Zhao 



















University of California, Santa Barbara - Department of Physics, Santa Barbara, California, USA

A. Barzdukas , L. Brennan , C. Campagnari , S. Carron Montero⁸⁴ , K. Downham , C. Grieco , M.M. Hussain, J. Incandela , M.W.K. Lai, A.J. Li , P. Masterson , J. Richman , S.N. Santpur , U. Sarica , R. Schmitz , F. Setti , J. Sheplock , D. Stuart , T.Á. Vámi , X. Yan , D. Zhang 

California Institute of Technology, Pasadena, California, USA

A. Albert , S. Bhattacharya , A. Bornheim , O. Cerri, R. Kansal , J. Mao , H.B. Newman , G. Reales Gutiérrez, T. Sievert, M. Spiropulu , J.R. Vlimant , R.A. Wynne , S. Xie 

Carnegie Mellon University, Pittsburgh, Pennsylvania, USA

J. Alison , S. An , M. Cremonesi, V. Dutta , E.Y. Ertorer , T. Ferguson , T.A. Gómez Espinosa , A. Harilal , A. Kallil Tharayil, M. Kanemura, C. Liu , M. Marchegiani , P. Meiring , T. Mudholkar , S. Murthy , P. Palit , K. Park , M. Paulini , A. Roberts , A. Sanchez , W. Terrill 









































































University of Colorado Boulder, Boulder, Colorado, USA

J.P. Cumalat , W.T. Ford , A. Hart , S. Kwan , J. Parkes , C. Savard , N. Schonbeck , K. Stenson , K.A. Ulmer , S.R. Wagner , N. Zipper , D. Zuolo 



















Cornell University, Ithaca, New York, USA

J. Alexander , X. Chen , J. Dickinson , A. Duquette, J. Fan , X. Fan , J. Grassi , S. Hogan , P. Kotamnives , J. Monroy , G. Niendorf , M. Oshiro , J.R. Patterson , A. Ryd , J. Thom , P. Wittich , R. Zou , L. Zygala 













Fermi National Accelerator Laboratory, Batavia, Illinois, USA

M. Albrow , M. Alyari , O. Amram , G. Apollinari , A. Apresyan , L.A.T. Bauerdick , D. Berry , J. Berryhill , P.C. Bhat , K. Burkett , J.N. Butler , A. Canepa , G.B. Cerati , H.W.K. Cheung , F. Chlebana , C. Cosby , G. Cummings , I. Dutta , V.D. Elvira , J. Freeman , A. Gandrakota , Z. Gecse , L. Gray , D. Green, A. Grummer , S. Grünendahl , D. Guerrero , O. Gutsche , R.M. Harris , T.C. Herwig , J. Hirschauer , V. Innocente , B. Jayatilaka , S. Jindariani , M. Johnson , U. Joshi , B. Klima , K.H.M. Kwok , S. Lammel , C. Lee , D. Lincoln , R. Lipton , T. Liu , K. Maeshima , D. Mason , P. McBride , P. Merkel , S. Mrenna , S. Nahn , J. Ngadiuba , D. Noonan , S. Norberg, V. Papadimitriou , N. Pastika , K. Pedro , C. Pena⁸⁵ , C.E. Perez Lara , F. Ravera , A. Reinsvold Hall⁸⁶ , L. Ristori , M. Safdari , E. Sexton-Kennedy , N. Smith , A. Soha , L. Spiegel , S. Stoynev , J. Strait , L. Taylor , S. Tkaczyk , N.V. Tran , L. Uplegger , E.W. Vaandering , C. Wang , I. Zoi 

University of Florida, Gainesville, Florida, USA

C. Aruta , P. Avery , D. Bourilkov , P. Chang , V. Cherepanov , R.D. Field, C. Huh , E. Koenig , M. Kolosova , J. Konigsberg , A. Korytov , G. Mitselmakher , K. Mohrman , A. Muthirakalayil Madhu , N. Rawal , S. Rosenzweig , V. Sulimov , Y. Takahashi , J. Wang 























Florida State University, Tallahassee, Florida, USA

T. Adams , A. Al Kadhim , A. Askew , S. Bower , R. Goff, R. Hashmi , A. Hassani , R.S. Kim , T. Kolberg , G. Martinez , M. Mazza , H. Prosper , P.R. Prova, R. Yohay 









Florida Institute of Technology, Melbourne, Florida, USA

B. Alsufyani , S. Butalla , S. Das , M. Hohlmann , M. Lavinsky, E. Yanes

University of Illinois Chicago, Chicago, Illinois, USA

M.R. Adams , N. Barnett, A. Baty , C. Bennett , R. Cavanaugh , R. Escobar Franco , O. Evdokimov , C.E. Gerber , H. Gupta , M. Hawksworth , A. Hingrajiya, D.J. Hofman , Z. Huang , J.h. Lee , C. Mills , S. Nanda , G. Nigmatkulov , B. Ozek , T. Phan, D. Pilipovic , R. Pradhan , E. Prifti, P. Roy, T. Roy , N. Singh, M.B. Tonjes , N. Varelas , M.A. Wadud , J. Yoo 













The University of Iowa, Iowa City, Iowa, USA

M. Alhusseini , D. Blend , K. Dilsiz⁸⁷ , O.K. Köseyan , A. Mestvirishvili⁸⁸ , O. Neogi, H. Ogul⁸⁹ , Y. Onel , A. Penzo , C. Snyder, E. Tiras⁹⁰ 







Johns Hopkins University, Baltimore, Maryland, USA

B. Blumenfeld , J. Davis , A.V. Gritsan , L. Kang , S. Kyriacou , P. Maksimovic , M. Roguljic , S. Sekhar , M.V. Srivastav , M. Swartz 













The University of Kansas, Lawrence, Kansas, USA

A. Abreu , L.F. Alcerro Alcerro , J. Anguiano , S. Arteaga Escatel , P. Baringer , A. Bean , R. Bhattacharya , Z. Flowers , D. Grove , J. King , G. Krintiras , M. Lazarovits , C. Le Mahieu , J. Marquez , M. Murray , M. Nickel , S. Popescu⁹¹ , C. Rogan , C. Royon , S. Rudrabhatla , S. Sanders , C. Smith , G. Wilson









Kansas State University, Manhattan, Kansas, USA

B. Allmond , N. Islam, A. Ivanov , K. Kaadze , Y. Maravin , J. Natoli , G.G. Reddy , D. Roy , G. Sorrentino

University of Maryland, College Park, Maryland, USA

A. Baden , A. Belloni , J. Bistany-riebman, S.C. Eno , N.J. Hadley , S. Jabeen , R.G. Kellogg , T. Koeth , B. Kronheim, S. Lascio , P. Major , A.C. Mignerey , C. Palmer , C. Papageorgakis , M.M. Paranjpe, E. Popova⁹² , A. Shevelev , L. Zhang









Massachusetts Institute of Technology, Cambridge, Massachusetts, USA

C. Baldenegro Barrera , H. Bossi , S. Bright-Thonney , I.A. Cali , Y.c. Chen , P.c. Chou , M. D'Alfonso , J. Eysermans , C. Freer , G. Gomez-Ceballos , M. Goncharov, G. Grosso , P. Harris, D. Hoang , G.M. Innocenti , K. Ivanov , D. Kovalskiy , J. Krupa , L. Lavezzo , Y.-J. Lee , K. Long , C. Mcginn , A. Novak , M.I. Park , C. Paus , C. Reissel , C. Roland , G. Roland , S. Rothman , T.a. Sheng , G.S.F. Stephans , D. Walter , J. Wang, Z. Wang , B. Wyslouch , T. J. Yang









University of Minnesota, Minneapolis, Minnesota, USA

B. Crossman , W.J. Jackson, C. Kapsiak , M. Krohn , D. Mahon , J. Mans , B. Marzocchi , R. Rusack , O. Sancar , R. Saradhy , N. Strobbe







University of Nebraska-Lincoln, Lincoln, Nebraska, USA

K. Bloom , D.R. Claes , G. Haza , J. Hossain , C. Joo , I. Kravchenko , A. Rohilla , J.E. Siado , W. Tabb , A. Vagnerini , A. Wightman , F. Yan









State University of New York at Buffalo, Buffalo, New York, USA

H. Bandyopadhyay , L. Hay , H.w. Hsia , I. Iashvili , A. Kalogeropoulos , A. Kharchilava , A. Mandal , M. Morris , D. Nguyen , S. Rappoccio , H. Rejeb Sfar, A. Williams , P. Young , D. Yu

Northeastern University, Boston, Massachusetts, USA















G. Alverson , E. Barberis , J. Bonilla , B. Bylsma, M. Campana , J. Dervan , Y. Haddad , Y. Han , I. Israr , A. Krishna , M. Lu , N. Manganelli , R. Mccarthy , D.M. Morse , T. Orimoto , L. Skinnari , C.S. Thoreson , E. Tsai , D. Wood

Northwestern University, Evanston, Illinois, USA









S. Dittmer , K.A. Hahn , M. Mcginnis , Y. Miao , D.G. Monk , M.H. Schmitt , A. Taliercio , M. Velasco , J. Wang

University of Notre Dame, Notre Dame, Indiana, USA

















G. Agarwal , R. Band , R. Bucci, S. Castells , A. Das , A. Ehnis, R. Goldouzian , M. Hildreth , K. Hurtado Anampa , T. Ivanov , C. Jessop , A. Karneyeu , K. Lannon

J. Lawrence , N. Loukas , L. Lutton , J. Mariano , N. Marinelli, I. Mcalister, T. McCauley , C. Mcgrady , C. Moore , Y. Musienko²³ , H. Nelson , M. Osherson , A. Piccinelli , R. Ruchti , A. Townsend , Y. Wan, M. Wayne , H. Yockey

The Ohio State University, Columbus, Ohio, USA

A. Basnet , M. Carrigan , R. De Los Santos , L.S. Durkin , C. Hill , M. Joyce , M. Nunez Ornelas , D.A. Wenzl, B.L. Winer , B. R. Yates 



















Princeton University, Princeton, New Jersey, USA

H. Bouchamaoui , G. Dezoort , P. Elmer , A. Frankenthal , M. Galli , B. Greenberg , N. Haubrich , K. Kennedy, G. Kopp , Y. Lai , D. Lange , A. Loeliger , D. Marlow , I. Ojalvo , J. Olsen , F. Simpson , D. Stickland , C. Tully 



University of Puerto Rico, Mayaguez, Puerto Rico, USA

S. Malik , R. Sharma 



















Purdue University, West Lafayette, Indiana, USA

S. Chandra , R. Chawla , A. Gu , L. Gutay, M. Jones , A.W. Jung , D. Kondratyev , M. Liu , G. Negro , N. Neumeister , G. Paspalaki , S. Piperov , N.R. Saha , J.F. Schulte , F. Wang , A. Wildridge , W. Xie , Y. Yao , Y. Zhong 











Purdue University Northwest, Hammond, Indiana, USA

N. Parashar , A. Pathak , E. Shumka 





















Rice University, Houston, Texas, USA

D. Acosta , A. Agrawal , C. Arbour , T. Carnahan , P. Das , K.M. Ecklund , S. Freed, F.J.M. Geurts , T. Huang , I. Krommydas , N. Lewis, W. Li , J. Lin , O. Miguel Colin , B.P. Padley , R. Redjimi , J. Rotter , C. Vico Villalba , M. Wulansatiti , E. Yigitbasi , Y. Zhang 

University of Rochester, Rochester, New York, USA

O. Bessidskaia Bylund, A. Bodek , P. de Barbaro[†] , R. Demina , A. Garcia-Bellido , H.S. Hare , O. Hindrichs , N. Parmar , P. Parygin⁹² , H. Seo , R. Taus 











Rutgers, The State University of New Jersey, Piscataway, New Jersey, USA

B. Chiarito, J.P. Chou , S.V. Clark , S. Donnelly, D. Gadkari , Y. Gershtein , E. Halkiadakis , C. Houghton , D. Jaroslawski , A. Kobert , S. Konstantinou , I. Laflotte , A. Lath , J. Martins , M. Perez Prada , B. Rand , J. Reichert , P. Saha , S. Salur , S. Schnetzer, S. Somalwar , R. Stone , S.A. Thayil , S. Thomas, J. Vora 











University of Tennessee, Knoxville, Tennessee, USA

D. Ally , A.G. Delannoy , S. Fiorendi , J. Harris, T. Holmes , A.R. Kanuganti , N. Karunarathna , J. Lawless, L. Lee , E. Nibigira , B. Skipworth, S. Spanier 

Texas A&M University, College Station, Texas, USA

D. Aebi , M. Ahmad , T. Akhter , K. Androsov , A. Bolshov, O. Bouhali⁹³ , A. Cagnotta , V. D'Amante , R. Eusebi , P. Flanagan , J. Gilmore , Y. Guo, T. Kamon , S. Luo , R. Mueller , A. Safonov 

Texas Tech University, Lubbock, Texas, USA







N. Akchurin , J. Damgov , Y. Feng , N. Gogate , Y. Kazhykarim, K. Lamichhane , S.W. Lee , C. Madrid , A. Mankel , T. Peltola , I. Volobouev 

Vanderbilt University, Nashville, Tennessee, USA

E. Appelt , Y. Chen , S. Greene, A. Gurrola , W. Johns , R. Kunnawalkam Elayavalli 

A. Melo , D. Rathjens , F. Romeo , P. Sheldon , S. Tuo , J. Velkovska , J. Viinikainen , J. Zhang

























University of Virginia, Charlottesville, Virginia, USA

B. Cardwell , H. Chung , B. Cox , J. Hakala , G. Hamilton Ilha Machado, R. Hirosky , M. Jose, A. Ledovskoy , C. Mantilla , C. Neu , C. Ramón Álvarez , Z. Wu

Wayne State University, Detroit, Michigan, USA

S. Bhattacharya , P.E. Karchin 











University of Wisconsin - Madison, Madison, Wisconsin, USA

A. Aravind , S. Banerjee , K. Black , T. Bose , E. Chavez , S. Dasu , P. Everaerts , C. Galloni, H. He , M. Herndon , A. Herve , C.K. Koraka , S. Lomte , R. Loveless , A. Mallampalli , A. Mohammadi , S. Mondal, T. Nelson, G. Parida , L. Pétré , D. Pinna , A. Savin, V. Shang , V. Sharma , W.H. Smith , D. Teague, H.F. Tsoi , W. Vetens , A. Warden 

Authors affiliated with an international laboratory covered by a cooperation agreement with CERN

S. Afanasiev , V. Alexakhin , Yu. Andreev , T. Aushev , D. Budkouski , R. Chistov , M. Danilov , T. Dimova , A. Ershov , S. Gninenko , I. Gorbunov , A. Gribushin , A. Kamenev , V. Karjavine , M. Kirsanov , V. Klyukhin , O. Kodolova⁹⁴ , V. Koronkov , I. Korsakov, A. Kozyrev , N. Krasnikov , A. Lanev , A. Malakhov , V. Matveev , A. Nikitenko^{95,94} , V. Palichik , V. Perelygin , S. Petrushanko , S. Polikarpov , O. Radchenko , M. Savina , V. Shalaev , S. Shmatov , S. Shulha , Y. Skovpen , K. Slizhevskiy, V. Smirnov , O. Teryaev , I. Tlisova , A. Toropin , N. Voytishin , A. Zarubin , I. Zhizhin 

Authors affiliated with an institute formerly covered by a cooperation agreement with CERN

E. Boos , V. Bunichev , M. Dubinin⁸⁵ , V. Savrin , A. Snigirev , L. Dudko , V. Kim²³ , V. Murzin , V. Oreshkin , D. Sosnov 

†: Deceased

¹Also at Yerevan State University, Yerevan, Armenia

²Also at TU Wien, Vienna, Austria

³Also at Ghent University, Ghent, Belgium

⁴Also at FACAMP - Faculdades de Campinas, Sao Paulo, Brazil

⁵Also at Universidade do Estado do Rio de Janeiro, Rio de Janeiro, Brazil

⁶Also at Universidade Estadual de Campinas, Campinas, Brazil

⁷Also at Federal University of Rio Grande do Sul, Porto Alegre, Brazil

⁸Also at The University of the State of Amazonas, Manaus, Brazil

⁹Also at University of Chinese Academy of Sciences, Beijing, China

¹⁰Also at China Center of Advanced Science and Technology, Beijing, China

¹¹Also at University of Chinese Academy of Sciences, Beijing, China

¹²Also at School of Physics, Zhengzhou University, Zhengzhou, China

¹³Now at Henan Normal University, Xinxiang, China

¹⁴Also at University of Shanghai for Science and Technology, Shanghai, China

¹⁵Now at The University of Iowa, Iowa City, Iowa, USA

¹⁶Also at Nanjing Normal University, Nanjing, China

¹⁷Also at Center for High Energy Physics, Peking University, Beijing, China

¹⁸Also at Cairo University, Cairo, Egypt

¹⁹Also at Suez University, Suez, Egypt

- ²⁰Now at British University in Egypt, Cairo, Egypt
- ²¹Also at Purdue University, West Lafayette, Indiana, USA
- ²²Also at Université de Haute Alsace, Mulhouse, France
- ²³Also at an institute formerly covered by a cooperation agreement with CERN
- ²⁴Also at University of Hamburg, Hamburg, Germany
- ²⁵Also at RWTH Aachen University, III. Physikalisches Institut A, Aachen, Germany
- ²⁶Also at Bergische University Wuppertal (BUW), Wuppertal, Germany
- ²⁷Also at Brandenburg University of Technology, Cottbus, Germany
- ²⁸Also at Forschungszentrum Jülich, Juelich, Germany
- ²⁹Also at CERN, European Organization for Nuclear Research, Geneva, Switzerland
- ³⁰Also at HUN-REN ATOMKI - Institute of Nuclear Research, Debrecen, Hungary
- ³¹Now at Universitatea Babeş-Bolyai - Facultatea de Fizica, Cluj-Napoca, Romania
- ³²Also at MTA-ELTE Lendület CMS Particle and Nuclear Physics Group, Eötvös Loránd University, Budapest, Hungary
- ³³Also at HUN-REN Wigner Research Centre for Physics, Budapest, Hungary
- ³⁴Also at Physics Department, Faculty of Science, Assiut University, Assiut, Egypt
- ³⁵Also at The University of Kansas, Lawrence, Kansas, USA
- ³⁶Also at Punjab Agricultural University, Ludhiana, India
- ³⁷Also at University of Hyderabad, Hyderabad, India
- ³⁸Also at Indian Institute of Science (IISc), Bangalore, India
- ³⁹Also at University of Visva-Bharati, Santiniketan, India
- ⁴⁰Also at IIT Bhubaneswar, Bhubaneswar, India
- ⁴¹Also at Institute of Physics, Bhubaneswar, India
- ⁴²Also at Deutsches Elektronen-Synchrotron, Hamburg, Germany
- ⁴³Also at Isfahan University of Technology, Isfahan, Iran
- ⁴⁴Also at Sharif University of Technology, Tehran, Iran
- ⁴⁵Also at Department of Physics, University of Science and Technology of Mazandaran, Behshahr, Iran
- ⁴⁶Also at Department of Physics, Faculty of Science, Arak University, ARAK, Iran
- ⁴⁷Also at Helwan University, Cairo, Egypt
- ⁴⁸Also at Italian National Agency for New Technologies, Energy and Sustainable Economic Development, Bologna, Italy
- ⁴⁹Also at Centro Siciliano di Fisica Nucleare e di Struttura Della Materia, Catania, Italy
- ⁵⁰Also at James Madison University, Harrisonburg, Maryland, USA
- ⁵¹Also at Università degli Studi Guglielmo Marconi, Roma, Italy
- ⁵²Also at Scuola Superiore Meridionale, Università di Napoli 'Federico II', Napoli, Italy
- ⁵³Also at Fermi National Accelerator Laboratory, Batavia, Illinois, USA
- ⁵⁴Also at Lulea University of Technology, Lulea, Sweden
- ⁵⁵Also at Ain Shams University, Cairo, Egypt
- ⁵⁶Also at Consiglio Nazionale delle Ricerche - Istituto Officina dei Materiali, Perugia, Italy
- ⁵⁷Also at UPES - University of Petroleum and Energy Studies, Dehradun, India
- ⁵⁸Also at Institut de Physique des 2 Infinis de Lyon (IP2I), Villeurbanne, France
- ⁵⁹Also at Department of Applied Physics, Faculty of Science and Technology, Universiti Kebangsaan Malaysia, Bangi, Malaysia
- ⁶⁰Also at Trincomalee Campus, Eastern University, Sri Lanka, Nilaveli, Sri Lanka
- ⁶¹Also at Saegis Campus, Nugegoda, Sri Lanka
- ⁶²Also at National and Kapodistrian University of Athens, Athens, Greece
- ⁶³Also at Ecole Polytechnique Fédérale Lausanne, Lausanne, Switzerland
- ⁶⁴Also at Universität Zürich, Zurich, Switzerland

-
- ⁶⁵Also at Stefan Meyer Institute for Subatomic Physics, Vienna, Austria
- ⁶⁶Also at Near East University, Research Center of Experimental Health Science, Mersin, Turkey
- ⁶⁷Also at Konya Technical University, Konya, Turkey
- ⁶⁸Also at Izmir Bakircay University, Izmir, Turkey
- ⁶⁹Also at Adiyaman University, Adiyaman, Turkey
- ⁷⁰Also at Bozok Universitetesi Rektörlüğü, Yozgat, Turkey
- ⁷¹Also at Istanbul Sabahattin Zaim University, Istanbul, Turkey
- ⁷²Also at Marmara University, Istanbul, Turkey
- ⁷³Also at Milli Savunma University, Istanbul, Turkey
- ⁷⁴Also at Informatics and Information Security Research Center, Gebze/Kocaeli, Turkey
- ⁷⁵Also at Kafkas University, Kars, Turkey
- ⁷⁶Now at Istanbul Okan University, Istanbul, Turkey
- ⁷⁷Also at Istanbul University - Cerrahpasa, Faculty of Engineering, Istanbul, Turkey
- ⁷⁸Also at Istinye University, Istanbul, Turkey
- ⁷⁹Also at Yildiz Technical University, Istanbul, Turkey
- ⁸⁰Also at School of Physics and Astronomy, University of Southampton, Southampton, United Kingdom
- ⁸¹Also at Monash University, Faculty of Science, Clayton, Australia
- ⁸²Also at Università di Torino, Torino, Italy
- ⁸³Also at Karamanoğlu Mehmetbey University, Karaman, Turkey
- ⁸⁴Also at California Lutheran University, Thousand Oaks, California, USA
- ⁸⁵Also at California Institute of Technology, Pasadena, California, USA
- ⁸⁶Also at United States Naval Academy, Annapolis, Maryland, USA
- ⁸⁷Also at Bingol University, Bingol, Turkey
- ⁸⁸Also at Georgian Technical University, Tbilisi, Georgia
- ⁸⁹Also at Sinop University, Sinop, Turkey
- ⁹⁰Also at Erciyes University, Kayseri, Turkey
- ⁹¹Also at Horia Hulubei National Institute of Physics and Nuclear Engineering (IFIN-HH), Bucharest, Romania
- ⁹²Now at another institute formerly covered by a cooperation agreement with CERN
- ⁹³Also at Hamad Bin Khalifa University (HBKU), Doha, Qatar
- ⁹⁴Also at Yerevan Physics Institute, Yerevan, Armenia
- ⁹⁵Also at Imperial College, London, United Kingdom