

Higher Order Modes Based Beam Phase Study: Simulations and Measurements

Presenter: L. Shi (U. Manchester / CI / DESY)

Members: N. Baboi (DESY), R.M. Jones (U. Manchester), T. Wamsat (DESY),
U. Mavric (WUT)

*22-24 August 2016,
Warnemünde*

The work is supported partly by EuCARD² with Grant No. GA 312453

Outline

- A brief introduction to the European XFEL and Higher Order Modes
- Principle of beam phase determination
- Simulations with circuit model
- Measurements with a broadband setup
- Summary and Outlook

Introduction to the European XFEL

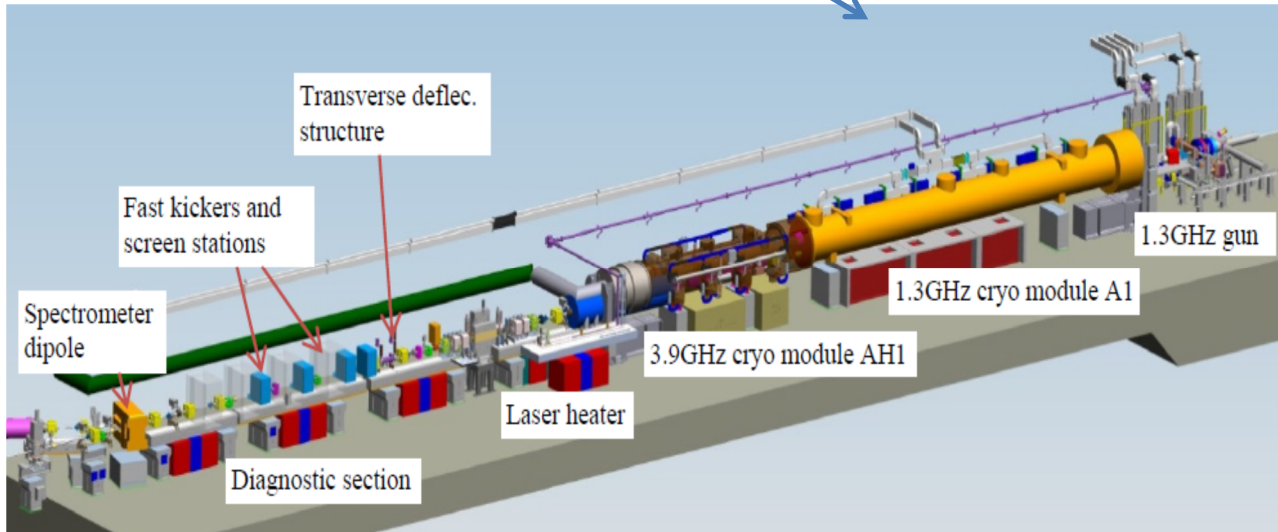
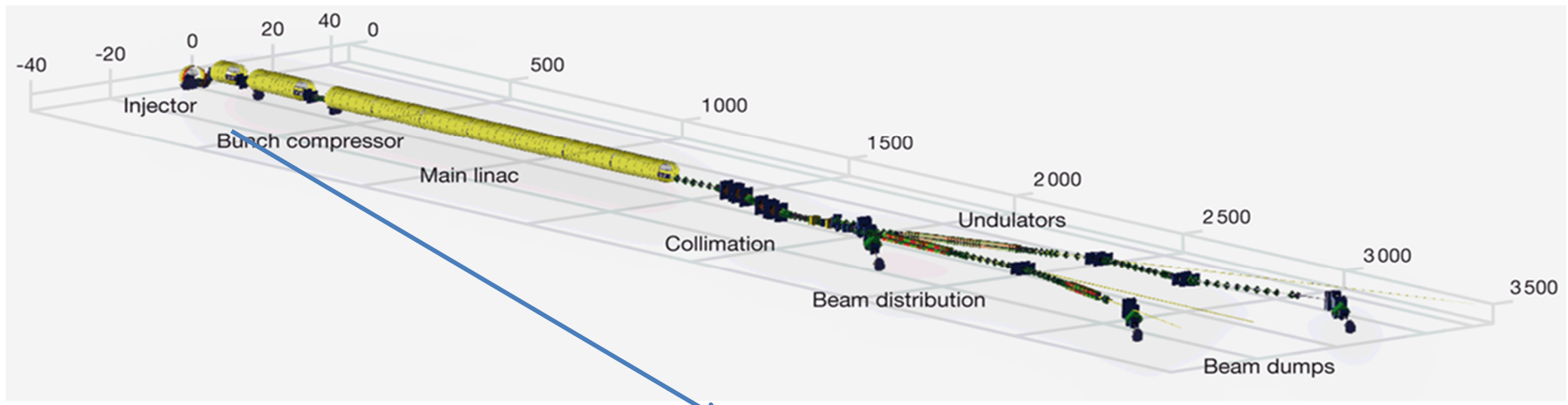

Electron Beam

Energy (GeV)	17.5, 14, 12, 8.5
Bunch Charge (nC)	0.02-1
Bunches/ train	1-2700
Bunch spacing (μ s)	0.2 (4.5 MHz)
Repetition rate (Hz)	10
Energy spread	< 1MeV

Commissioning of the European XFEL Injector, Frank Brinker, IPAC2016, PP1044

Introduction to Higher Order Modes (HOM)

When beam transverses a cavity, wakefields are excited. These fields are classified into monopole, dipole, quadrupole modes etc.

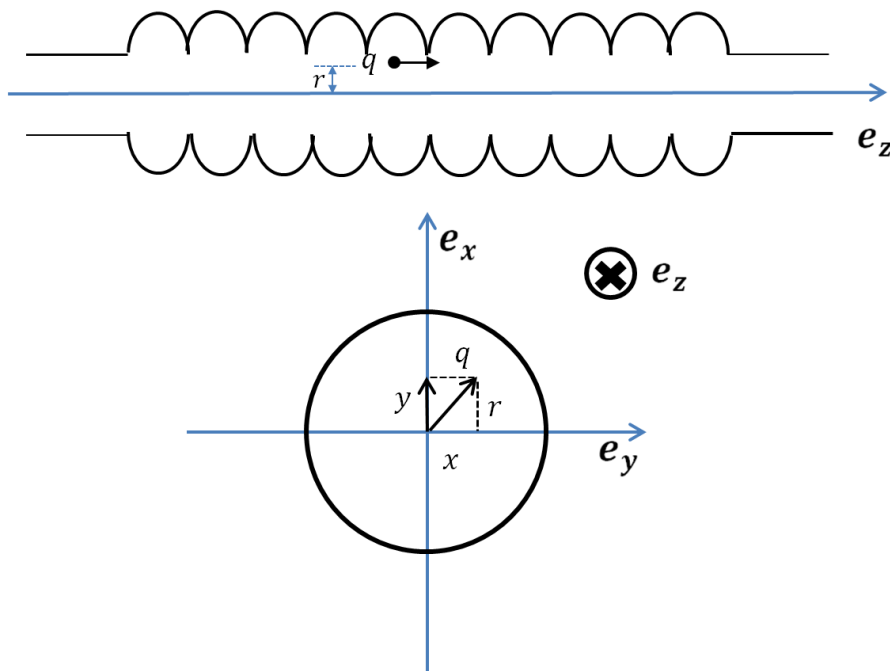

R. Wanzenberg, TESLA 2001-33, 2001.

- Monopole modes dominate the longitudinal wakefield:

$$W_{\parallel} \cong - \sum_n \omega_n \left(\frac{R}{Q}\right)^n \cos\left(\frac{\omega_n s}{c}\right) H(s) \cdot \mathbf{e}_z$$

- Dipole modes dominate the transverse wakefield:

$$W_{\perp} \cong (x\mathbf{e}_x + y\mathbf{e}_y) c \sum_n \left(\frac{R}{Q}\right)^n \sin\left(\frac{\omega_n s}{c}\right) H(s)$$

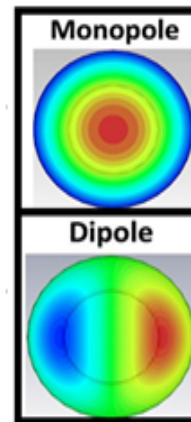

Measured Quantity $\propto q \cdot \frac{R}{Q}$

Bunch charge

Measured Quantity $\propto q \cdot r \cdot \frac{R}{Q}$

Bunch offset

TESLA Cavity and HOM spectrum

- TESLA Cavity (1.3 GHz)

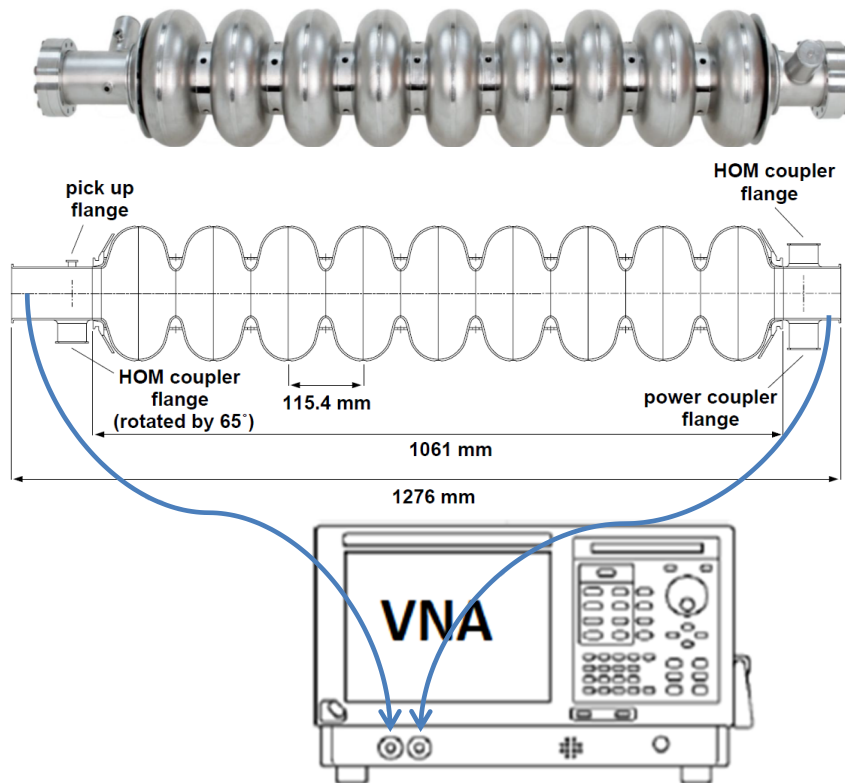

- HOM Spectrum

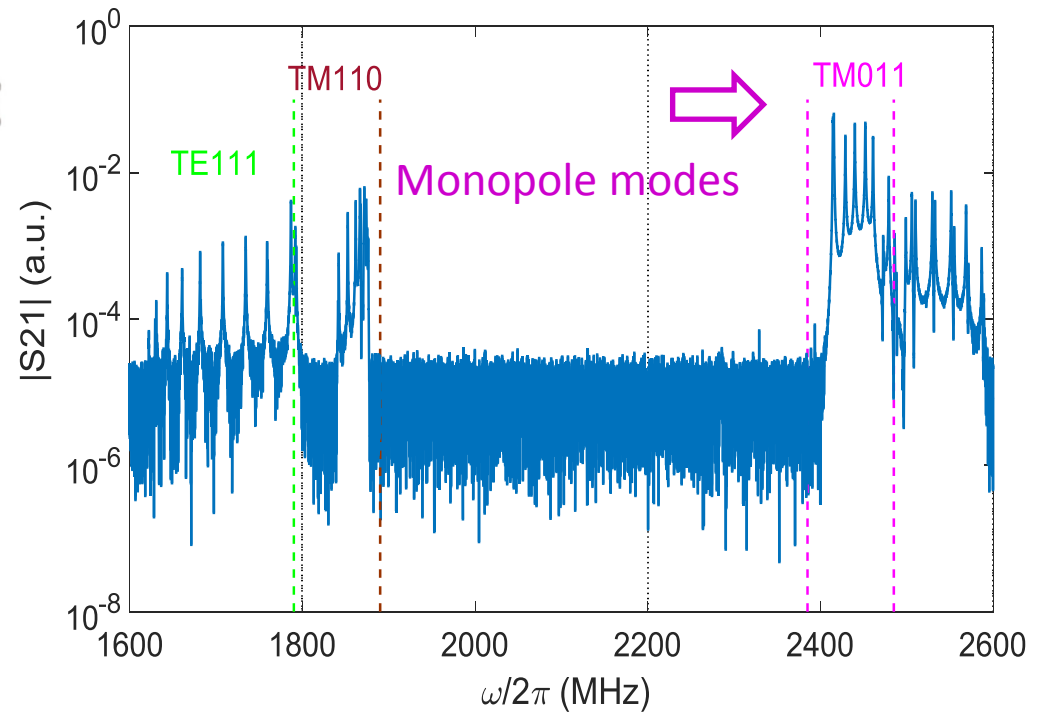

Monopole band occupies ~ 2.4 GHz with 70 MHz (2.38-2.45 GHz) bandwidth. The last two modes are with higher R/Q ($\sim 70 \Omega$).

- Introduction
- Principle of beam phase determination
- Simulation with circuit model
- Measurements with a broadband setup
- Summary and Outlook

Field Control inside a cavity

- FEL operation requires high stability of RF amplitude and phase. Requirements are derived from beam properties:

- Energy spread
- Emittance
- Bunch length
- Arrival time

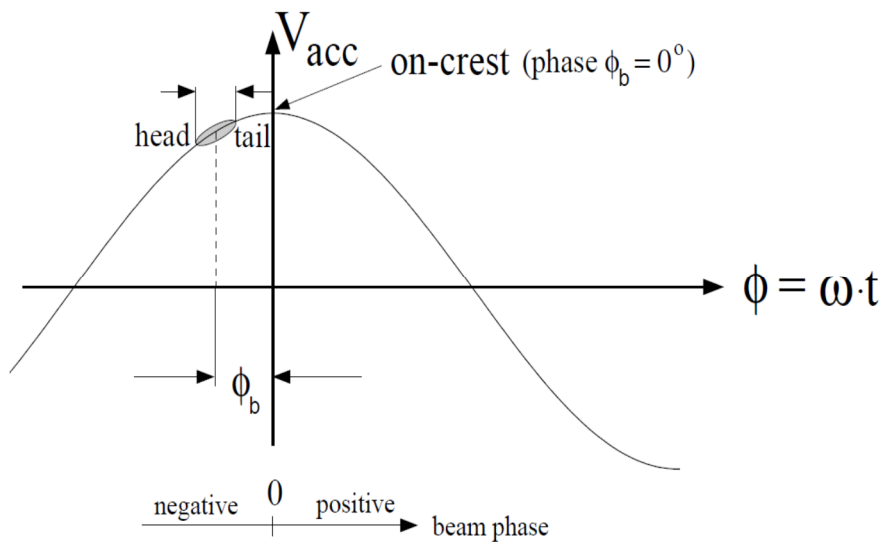

Phase 0 is defined as on crest.

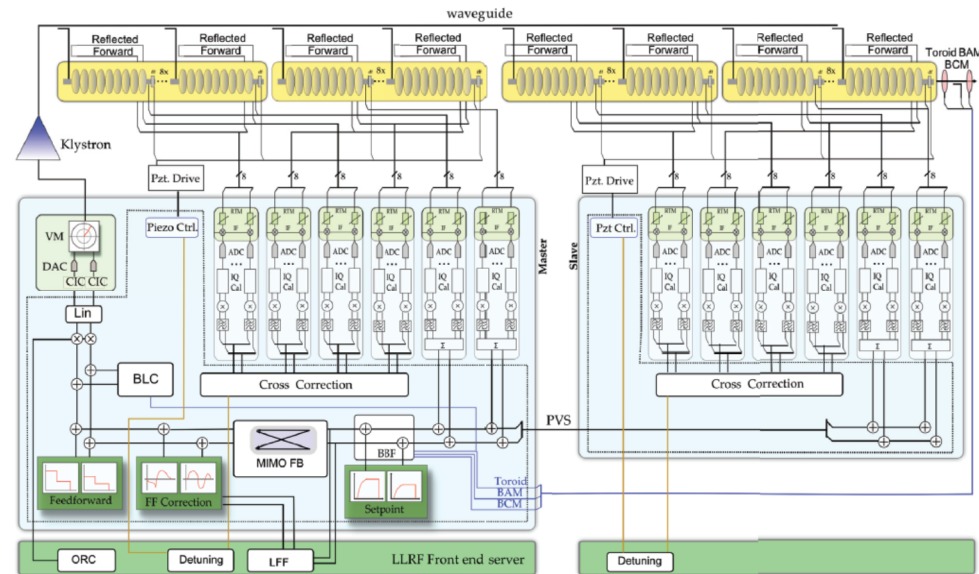

	Amp	Phase
FLASH	0.01%	0.01 degree
E-XFEL	0.01%	0.01 degree

How to determine the beam phase?

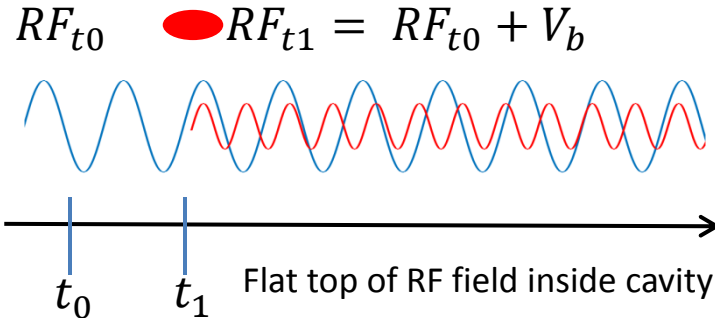

RF_{t_0} : 1.3 GHz signal

V_b : ~2.4 GHz beam induced signal

RF_{t_1} : 1.3 + 2.4 GHz signal

- Assume: $x_r(t) = \sum_{i=1}^N \cos(\omega_i t + \varphi_i)$

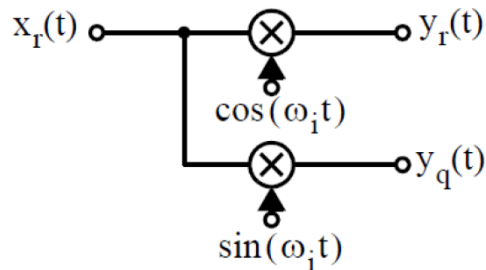

$$y_r(t) = \frac{\cos(2\omega_i t + \varphi_i) + \cos(\varphi_i)}{2}$$

$$y_q(t) = \frac{\sin(2\omega_i t + \varphi_i) + \sin(-\varphi_i)}{2}$$

$$\tan(\varphi_i) = \frac{\int y_q(t) dt}{\int y_r(t) dt}$$

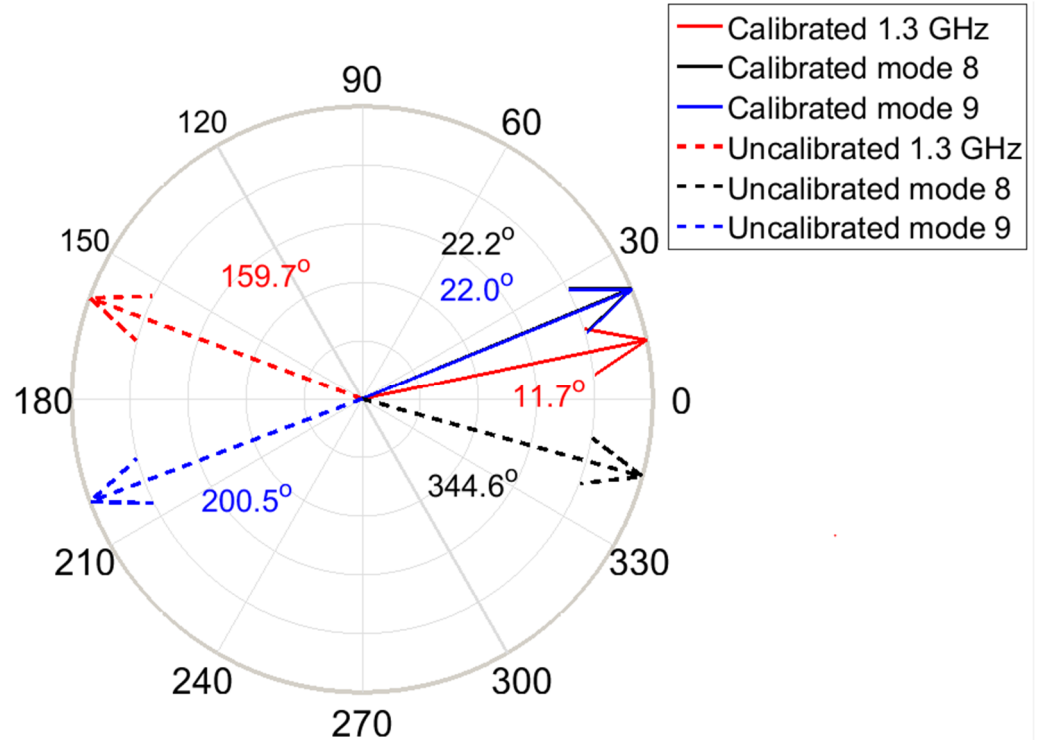

φ_i s from HOMs can be used to define beam arrival time t_1 and the phase relative to this time for 1.3 GHz signal can be calculated.

Signal strength estimation

- Assume the gradient is 20 MV/m and 0.5 nC bunch charge
 - ❑ Beam induced fundamental mode: $2 * 0.5 \text{ nC} * 2.08 \text{ V/pC} = 2080 \text{ V}$;
 - ❑ Beam induced high order monopole mode $2 * 0.5 \text{ nC} * 0.6 \text{ V/pC} = 600 \text{ V}$;
 - ❑ Direct measurement of the fundamental mode (induced from klystron and beam) needs a large dynamic range.
 - ❑ The fundamental mode signals from HOM couplers are comparable to that of damped higher order modes.

TESLA cavity simulation

Mode	Loss factor
Pi (1.3 GHz)	2.08 V/pC
TM011 (2.4499GHz)	0.08 V/pC
TM011 (2.4419GHz)	0.60 V/pC
TM011 (2.4539GHz)	0.57 V/pC

- Introduction
- Principle of beam phase determination
- Simulation with circuit model
- Measurements with a broadband setup
- Summary and Outlook

A single chain coupled circuit model

- A single chain of coupled parallel LC circuit is used to facilitate the beam phase monitor development.

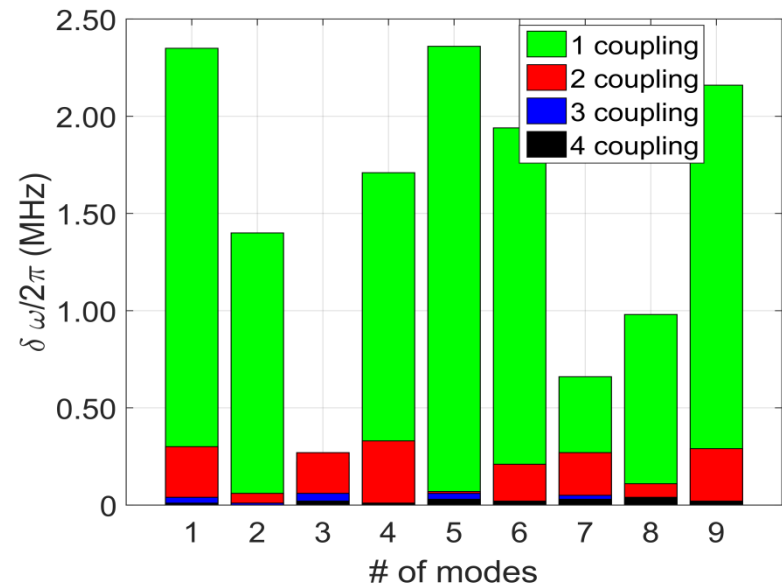
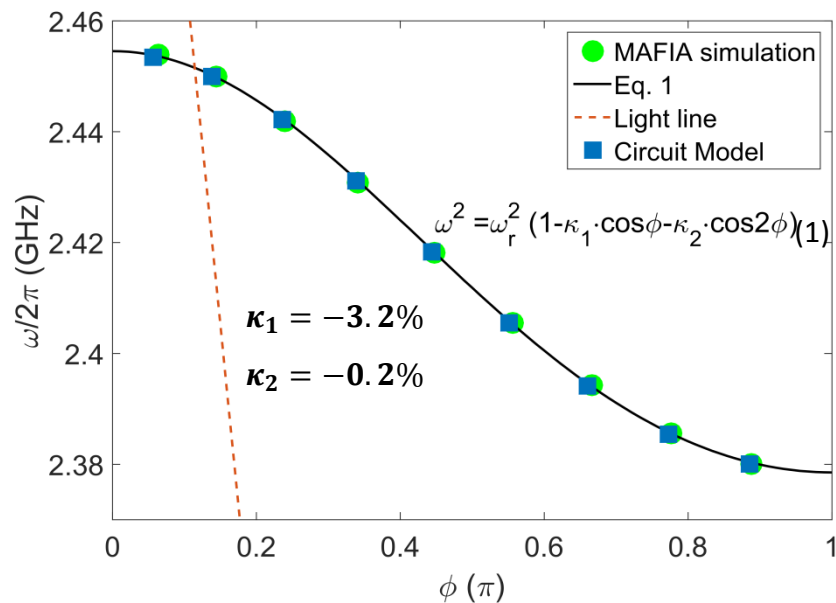
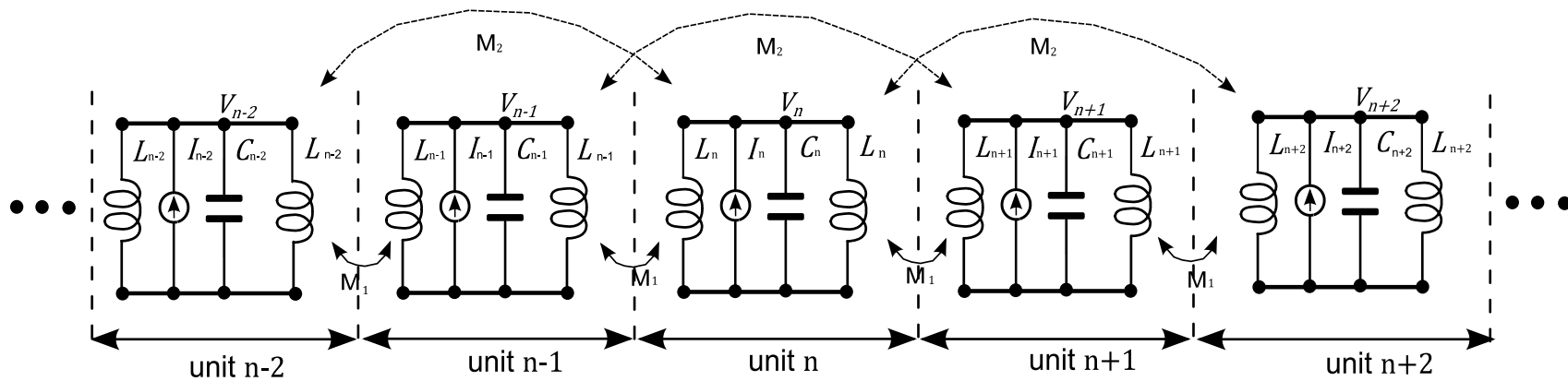

Beam driven circuit model

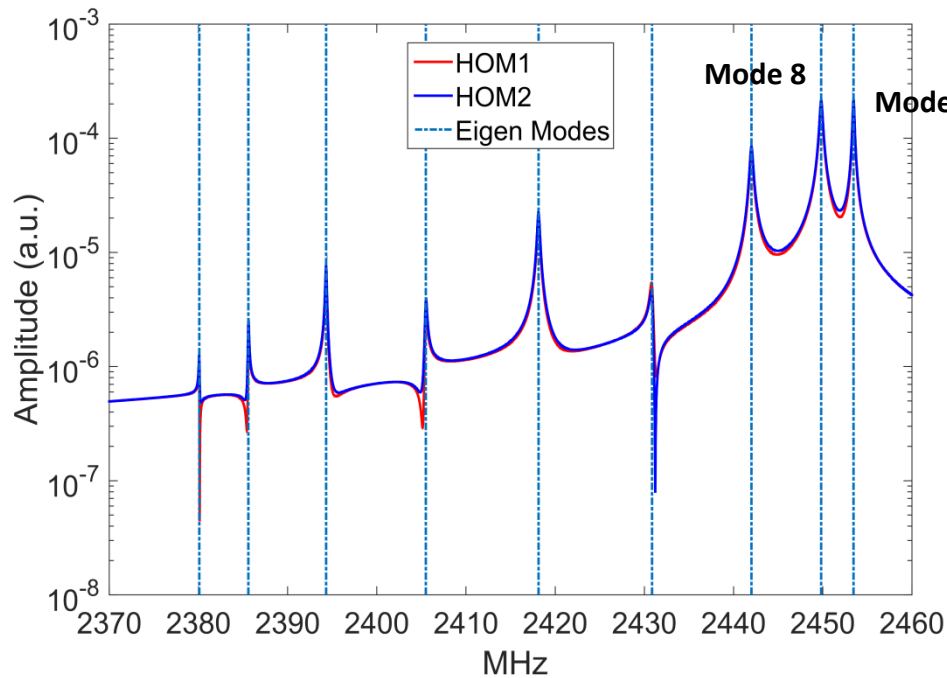
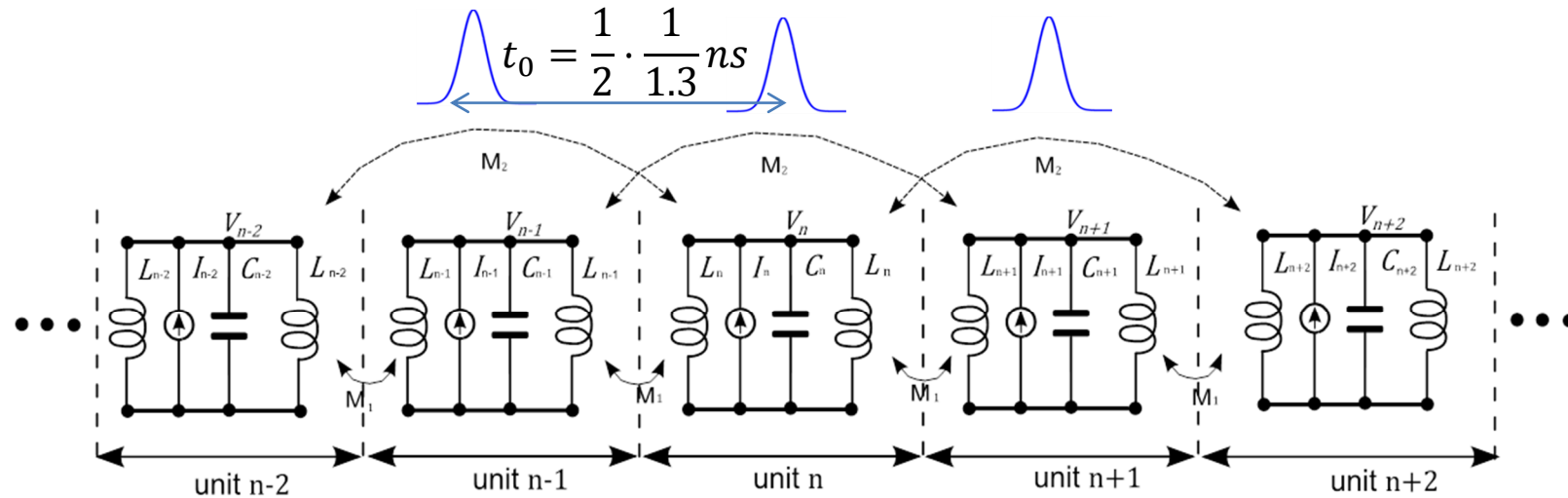

- Circuit is truncated to nine cells.
- It is then driven with delayed Gaussian pulses.
- The last two modes are excited strongly, and are used for beam phase calculation.

Resolution study - Circuit model

1. Vary the sampling frequency, while keeping other parameters constant
2. Vary the noise level, while keeping other parameters constant
3. By comparing phases calculated from two HOM couplers, resolution can be estimated.

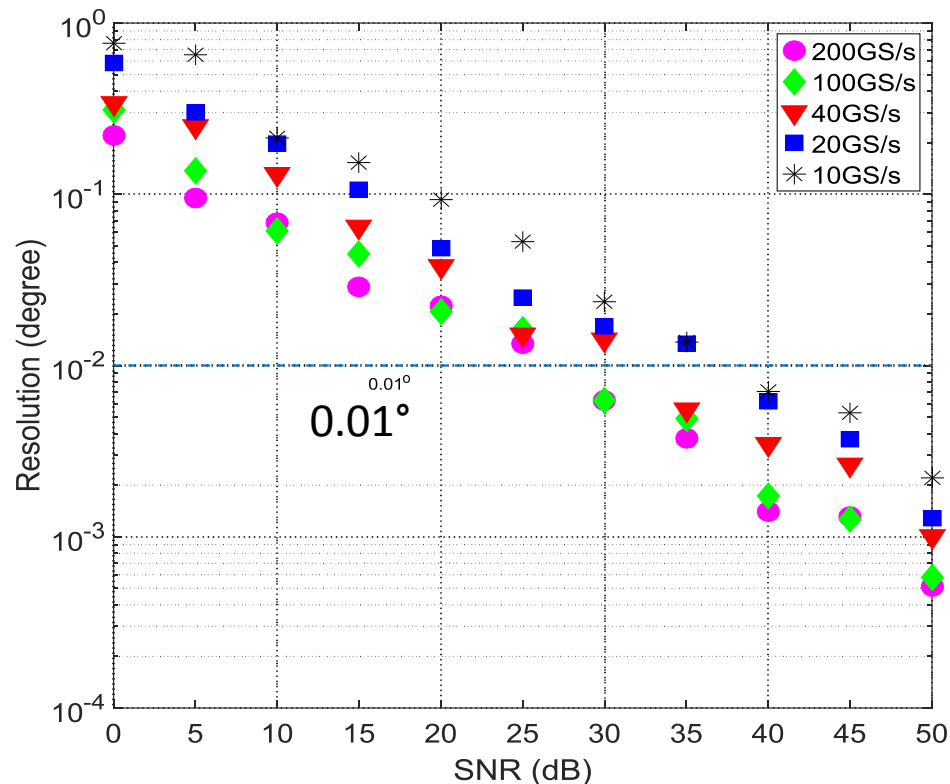

1. The resolution clearly depends exponentially on the noise present in the system.
2. The resolution also depends on the sampling frequency.
3. In order to meet the 0.01 degree requirement, the SNR is at least 35 dB

- Introduction
- Principle of beam phase determination
- Simulation with circuit model
- Measurements with a broadband setup
- Summary and Outlook

Experimental Setup

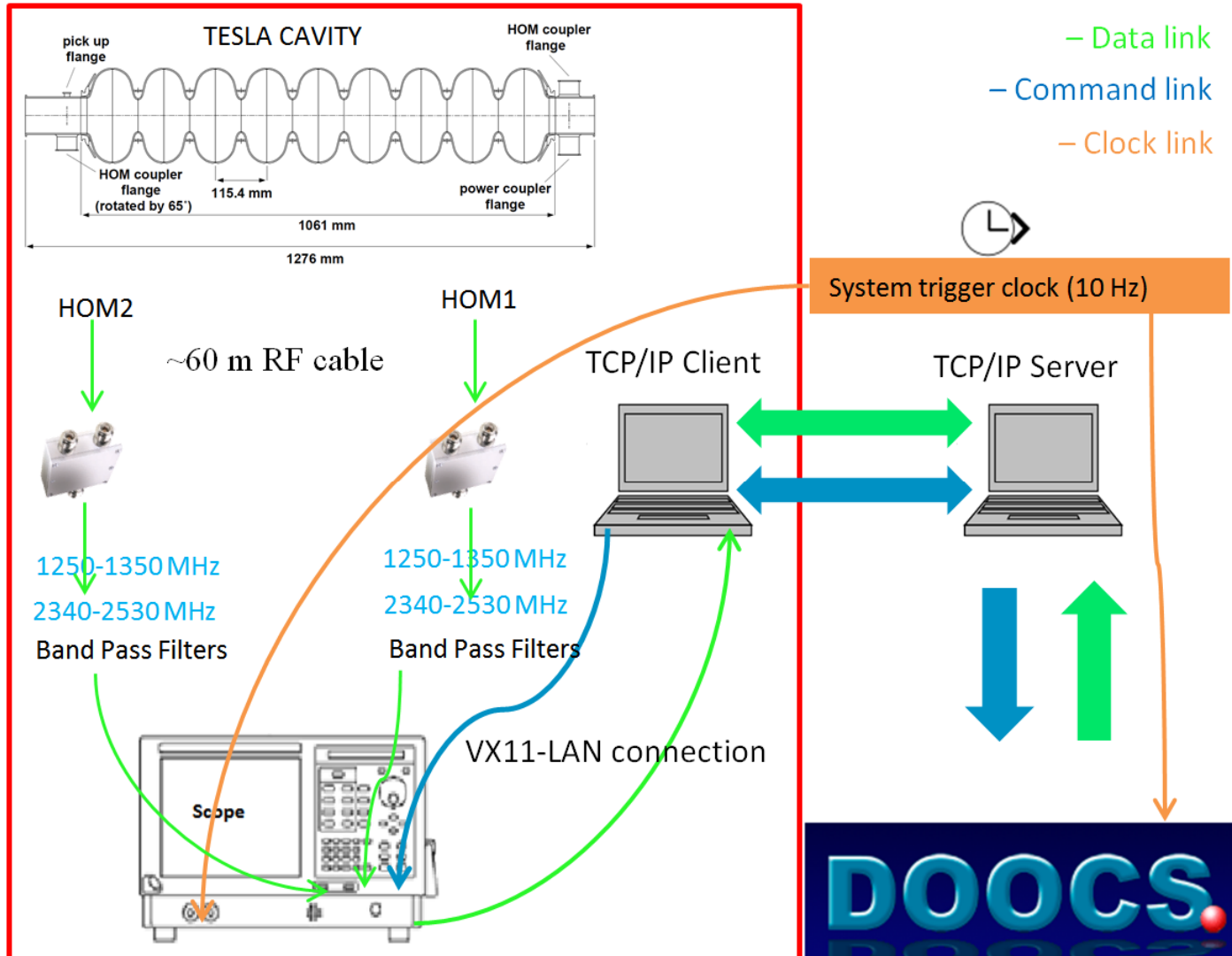

– Data link

– Command link

– Clock link

- HOM signals are available from HOM Patch panel.
- A fast scope (TDS6604B) with 20 GS/s, 6 GHz bandwidth is connected for two channels for HOM signals.
- A 10 Hz external clock is used to synchronize the measurement.
- The data from DOOCS and from scope are combined at TCP/IP Client
- Each triggered event takes ~ 20s

Estimation of Noise based on SVD

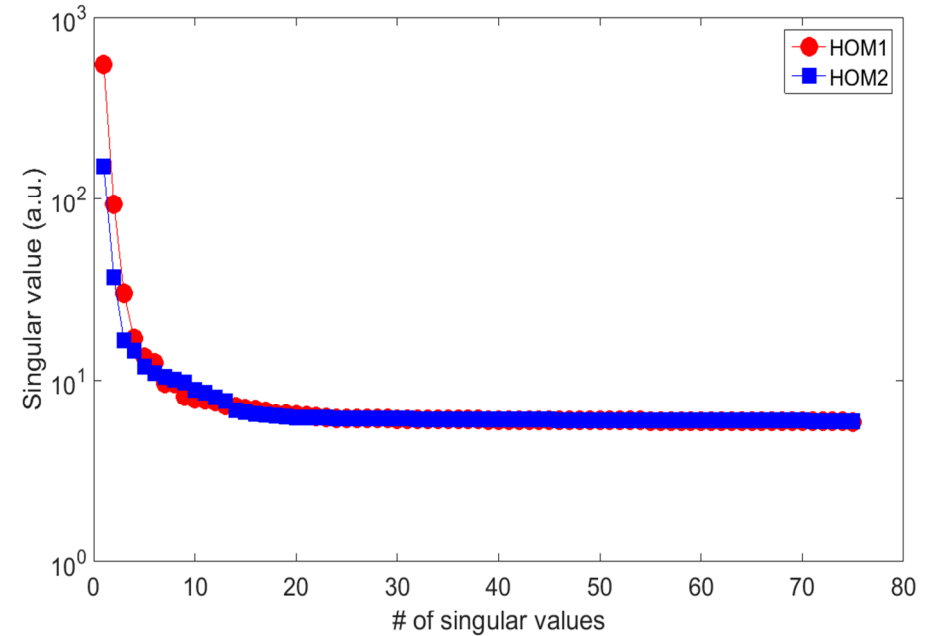
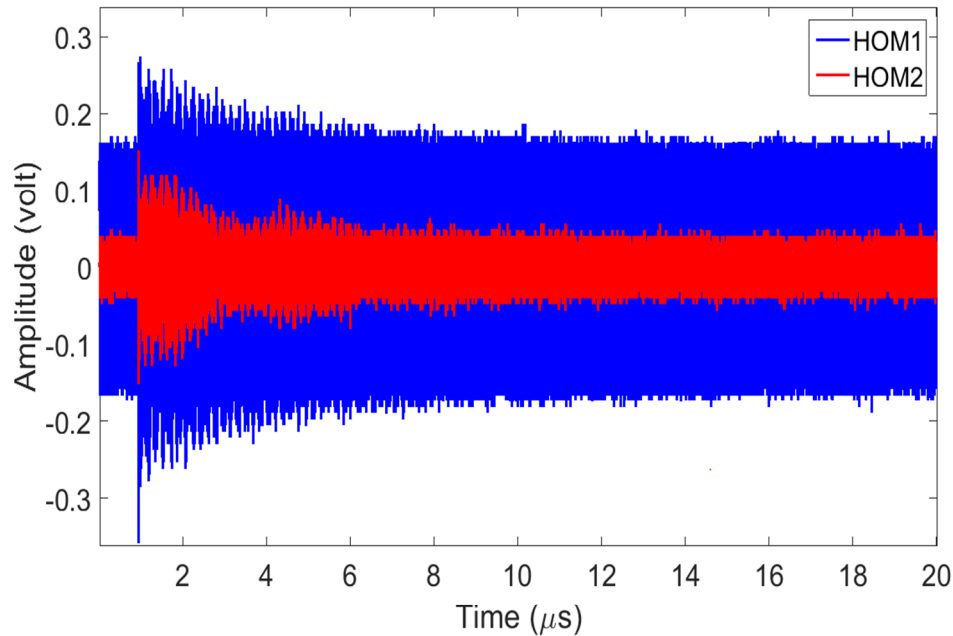

- $D = USV^T$
- S contains the singular values associated with the signal
- Top 24 singular values are used to reconstruct the signal. The rest is regarded as noise.
- The noise level is approximately 8 mV in RMS. SNR is ~ 20 dB for HOM1 and ~ 10 dB for HOM2.

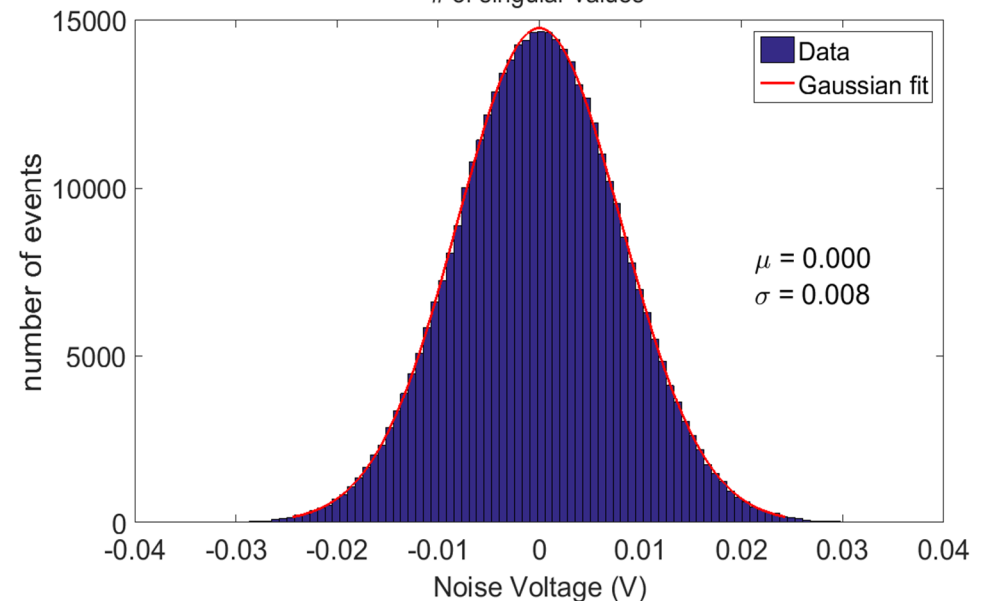

Resolution over charge

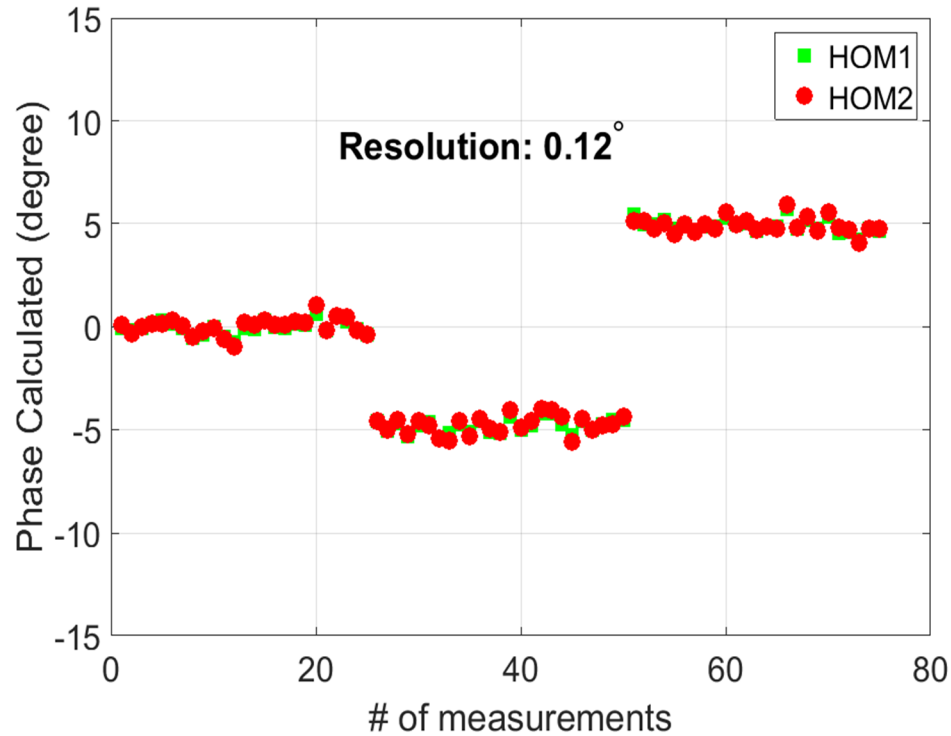

- The beam charge was varied from 0.1 to 1 nC with a step of 0.1 nC
- The simulation data was scaled with real measurements.

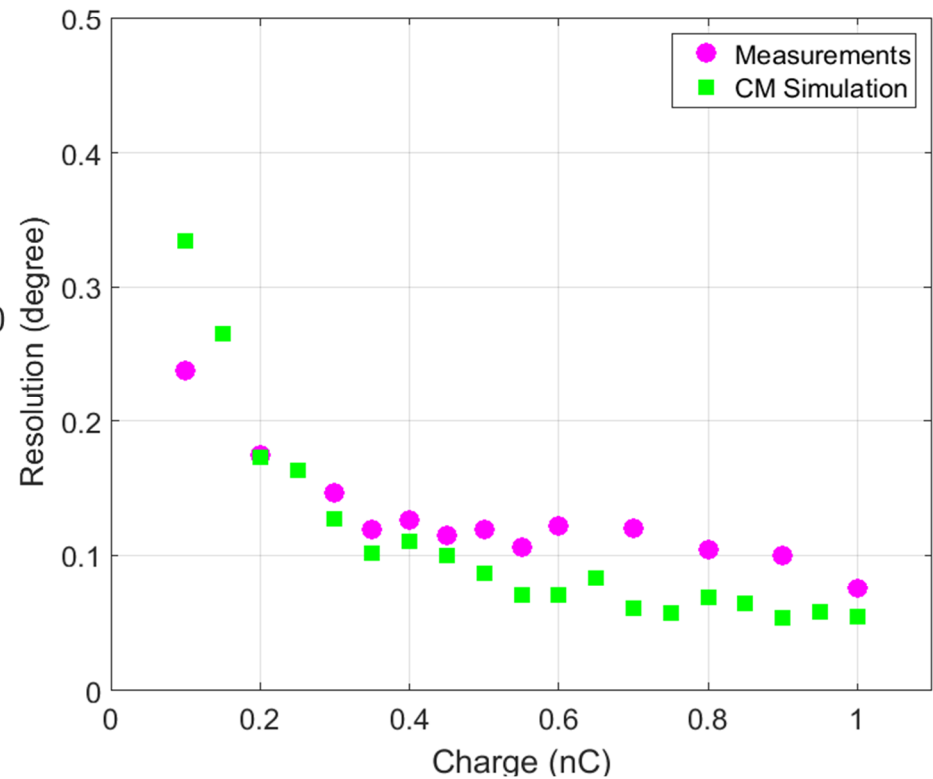

- Experiment (20 GS/s) @22MV/m, 0.5 nC
- Beam phase is varied at 0, -5, and 5 degree from DOOCS.

HOM Phase vs LLRF result

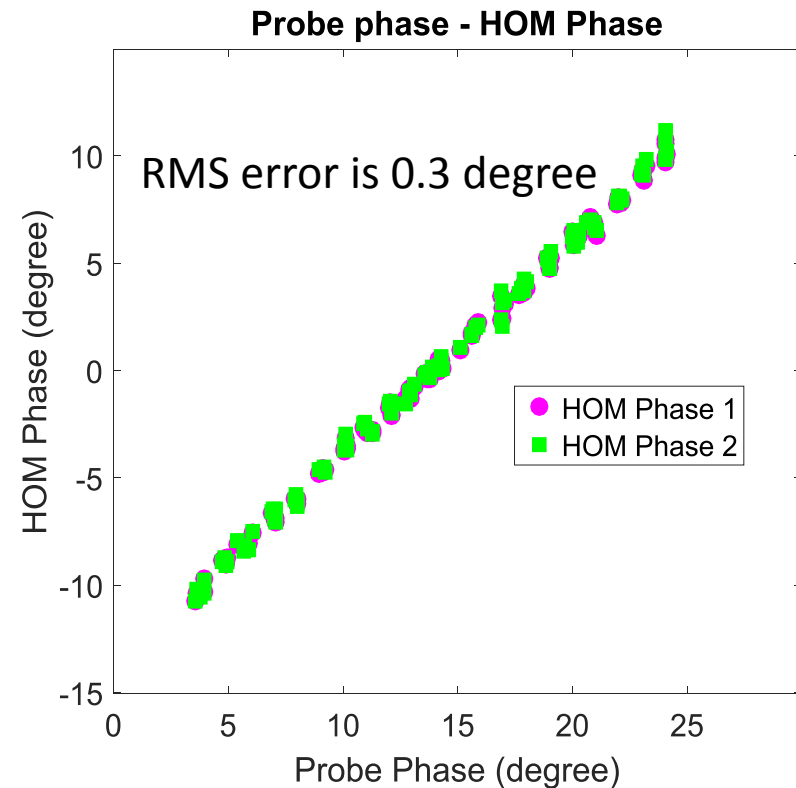
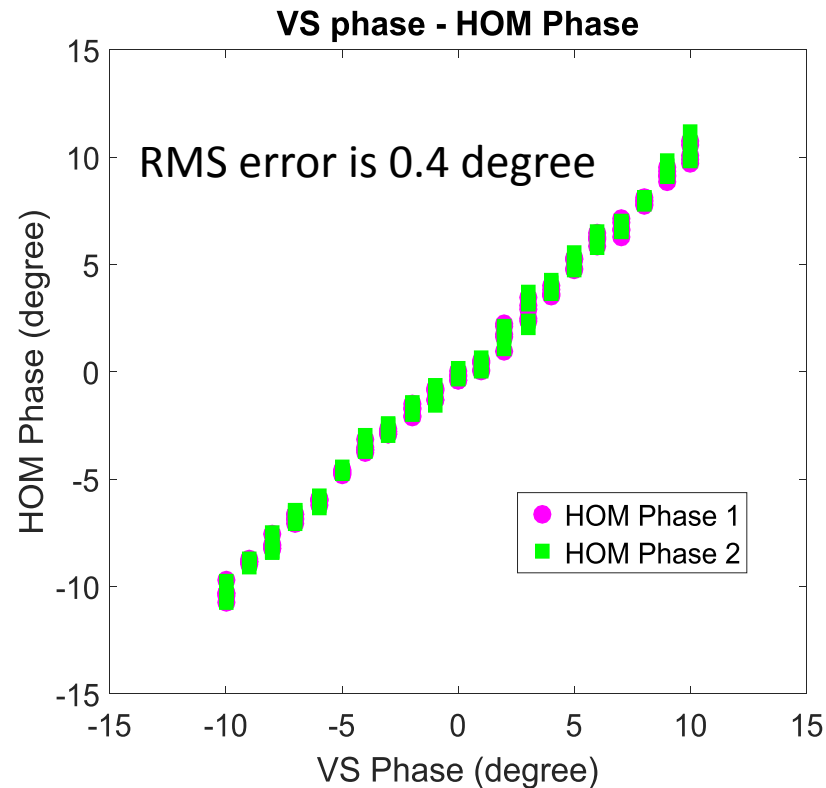

- Phase was changed from -10 to 10 degree with a step of 1 degree.
- Up to a calibration offset, the probe phase agrees with the phase from HOM. Note the measurement system is not fully synchronized.

Resolution limit estimation

Simulation data with 0.5 nC and 20 GS/s

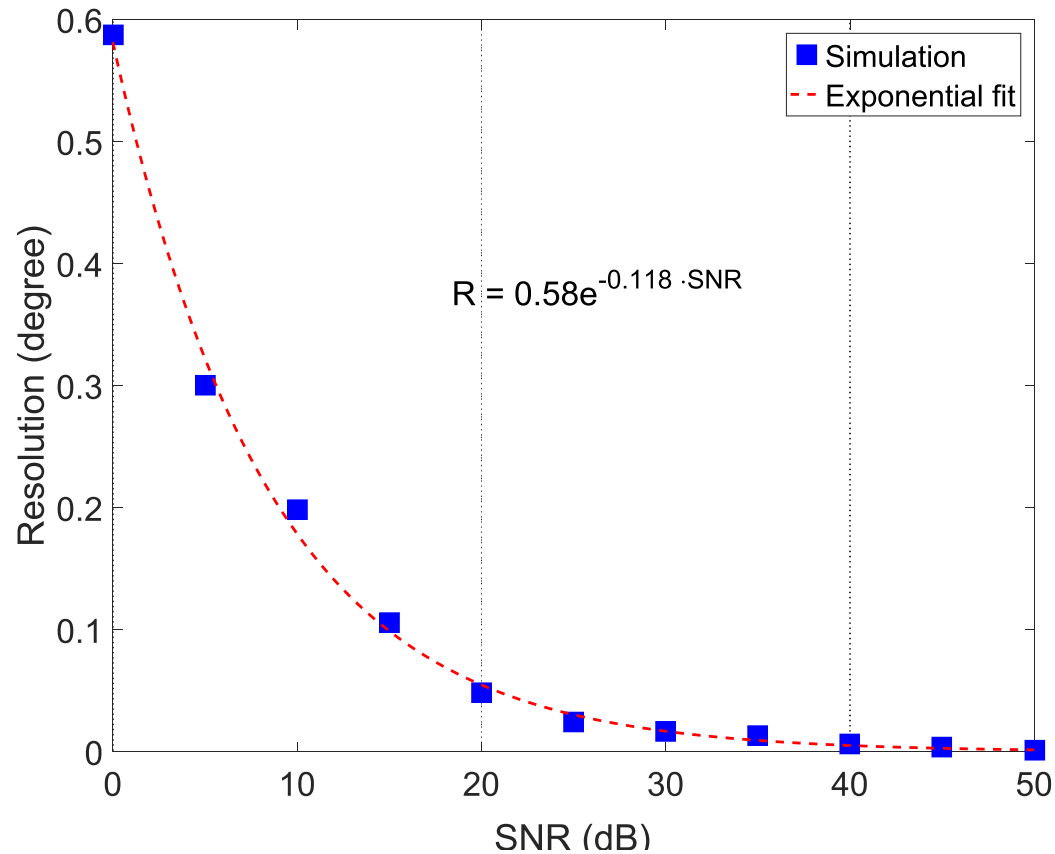

- Minimal detectable thermal noise:
 $U_{th} = \frac{1}{2}k_bT = 0.0129 \text{ eV @ } 300K;$
- Energy deposited in a monopole mode:
 $kq^2 = 9.4 \cdot 10^{11} \text{ eV with } 0.5 \text{ nC}$
- By assuming 0.5 power coupling, the SNR is approximately 136 dB, which suggests $\sim 10^{-8}$ degree resolution.
- By scaling the power of simulation signal based on measurements, the difference between simulation and measurement is 0.05 degree.

Electronics of HOM based Beam Phase Monitor

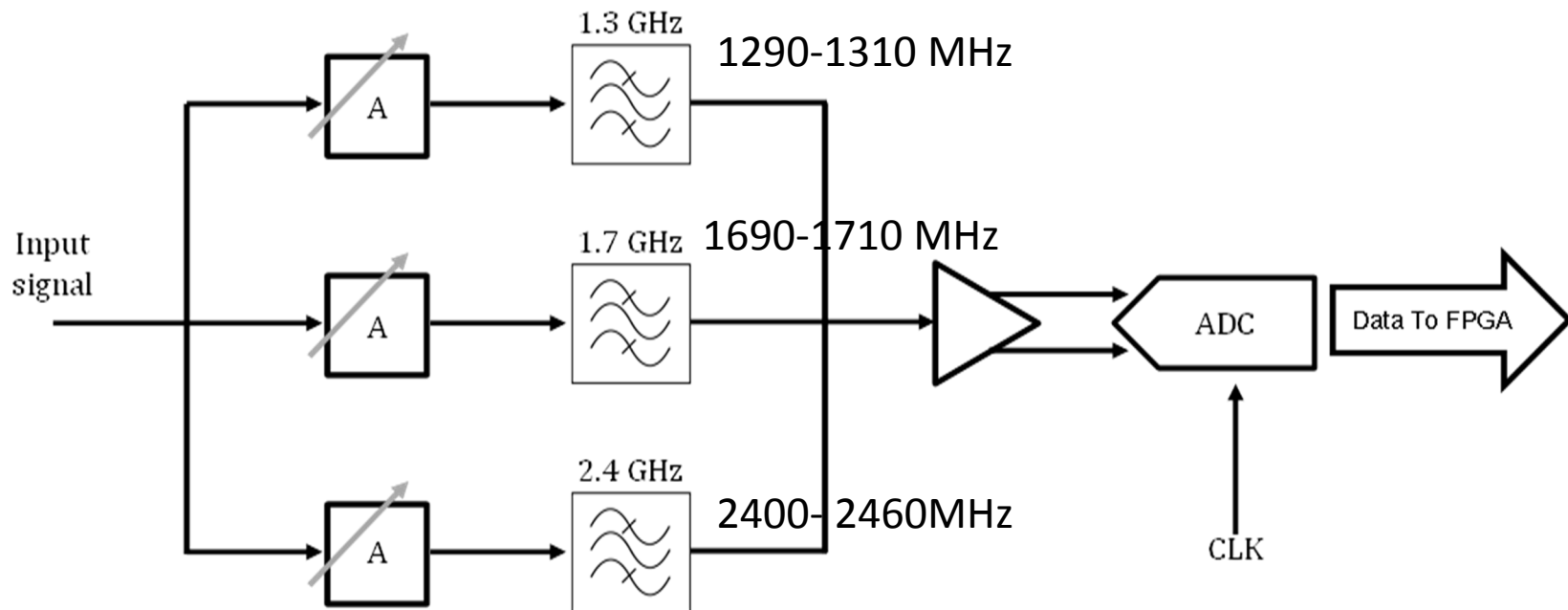

- The electronics are compact and can be used for beam phase and beam position measurements.
- It fully complies with MicroTCA.4 standard.

Possible topologies of final system

- Process at the front end and transmit the results **over long distance**.

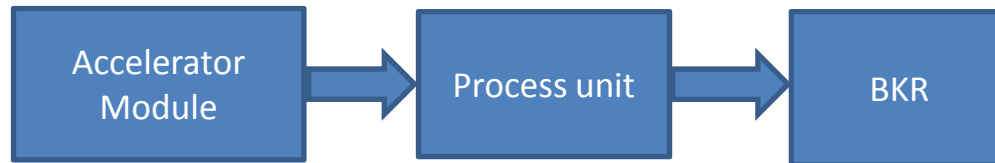

Vicinity of the module

+ Less influence from the intermediate units

- Radiation protection

- Transmit the signal **over long distance** and process in the middle

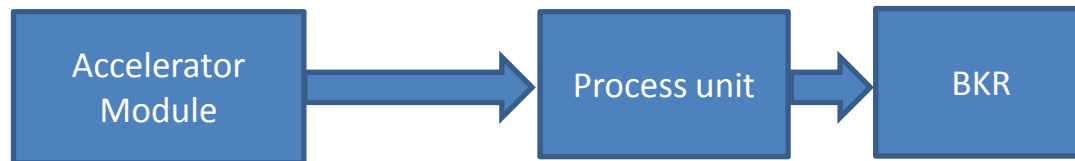

Longer cable to different site

+ No need for radiation protection.

- Signal integrity issue

Summary and Outlook

- ❑ Circuit model aided the development of beam phase monitor.
- ❑ At least 35 dB SNR is required to achieve 0.01 degree resolution.
- ❑ SVD method is used to estimate noise level. Simulation and measurements agree well with each other.
- ❑ Beam phase based on HOM is consistent with the phase from LLRF.
- ❑ Signal power optimization is required to further improve the resolution.
- ❑ The hardware development for the beam phase monitor is ongoing.
- ❑ It is promising to integrate the monitor into LLRF system.

Thank you for your attention!