

The Mu3e Experiment



Niklaus Berger

Physikalisches Institut, Universität Heidelberg

Lepton Moments 2014

Emmy
Noether-
Programm

Deutsche
Forschungsgemeinschaft

DFG



Overview

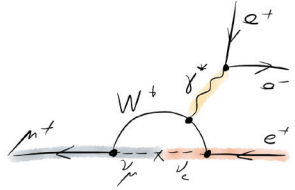

- The Charge:

Can we find lepton flavour violating μ -decays?

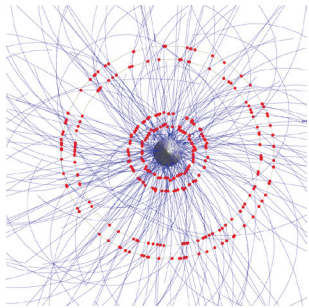

- The Challenge:

Finding one in 10^{16} muon decays



- The Mu3e Detector:

Minimum Material, Maximum Precision



The hunt for charged lepton flavour violation in μ -decays

LFV Muon Decays: Experimental Situation

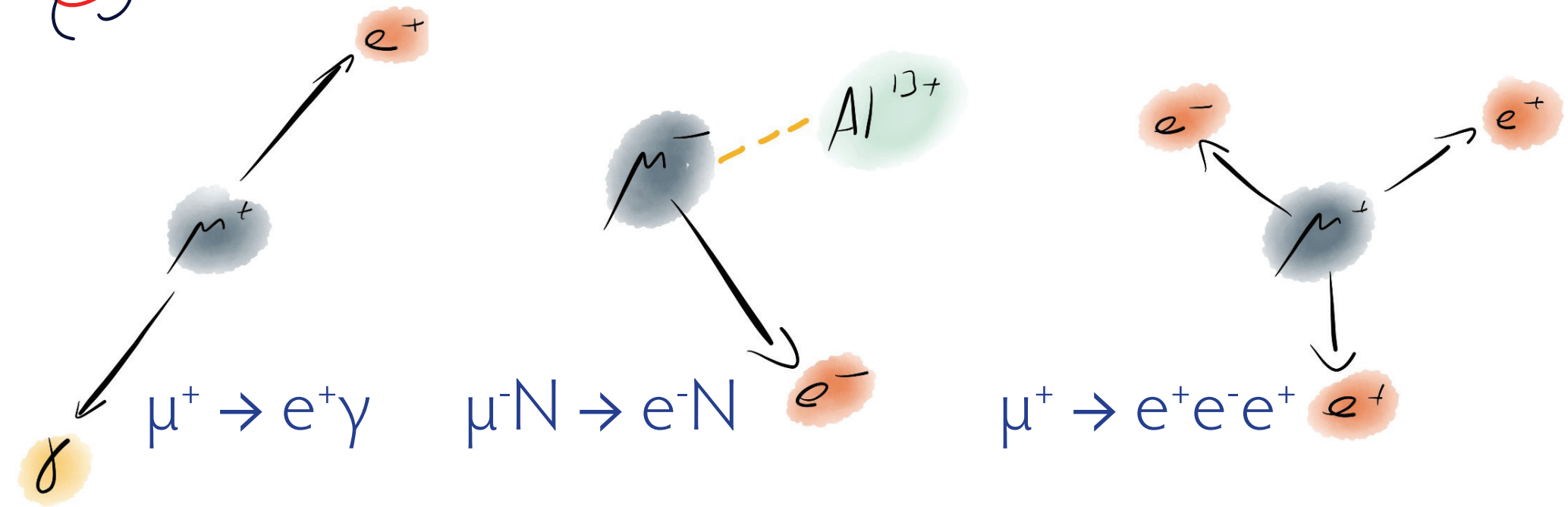

MEG (PSI)

$$B(\mu^+ \rightarrow e^+ \gamma) < 5.7 \cdot 10^{-13}$$

(2013)

SINDRUM II (PSI)

$$B(\mu^- Au \rightarrow e^- Au) < 7 \cdot 10^{-13}$$

(2006)

SINDRUM (PSI)

$$B(\mu^+ \rightarrow e^+ e^- e^+) < 1.0 \cdot 10^{-12}$$

(1988)

LFV Muon Decays: Experimental Situation

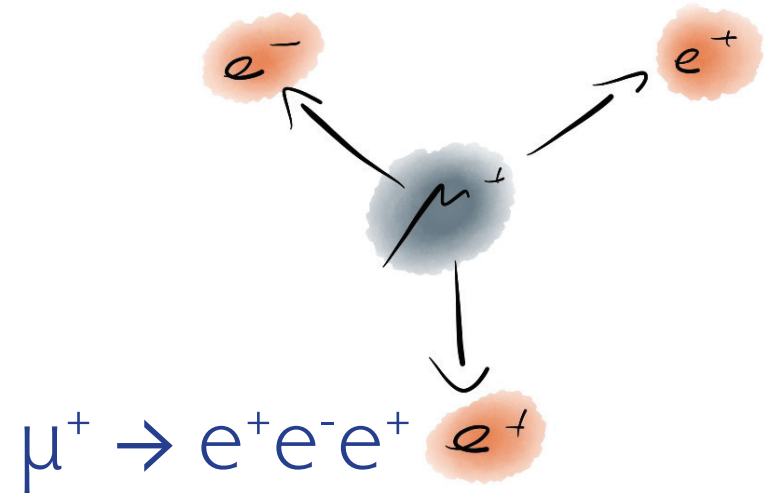
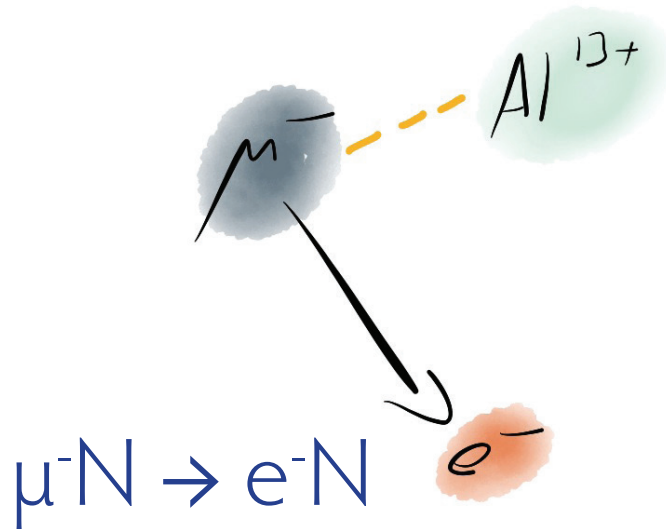
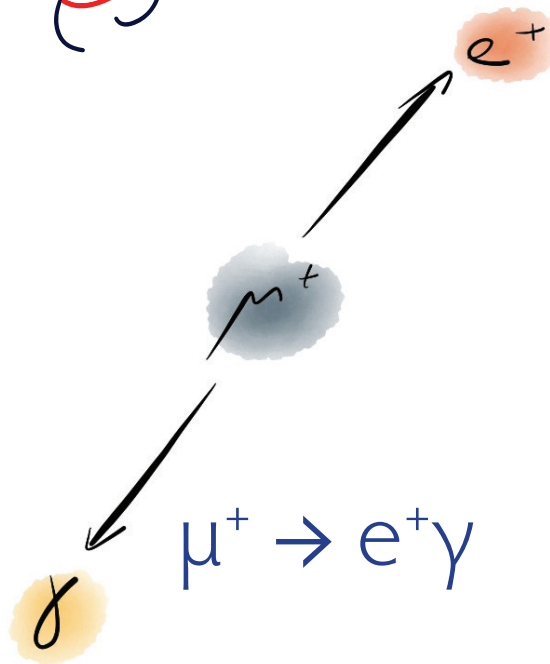

MEG (PSI)

$$B(\mu^+ \rightarrow e^+ \gamma) < 5.7 \cdot 10^{-13} \quad (2013)$$

upgrading

SINDRUM II (PSI)

$$B(\mu^- \text{Au} \rightarrow e^- \text{Au}) < 7 \cdot 10^{-13} \quad (2006)$$

Mu2e/Comet

SINDRUM (PSI)

$$B(\mu^+ \rightarrow e^+ e^- e^+) < 1.0 \cdot 10^{-12} \quad (1988)$$

Mu3e

LFV Muon Decays: Experimental signatures

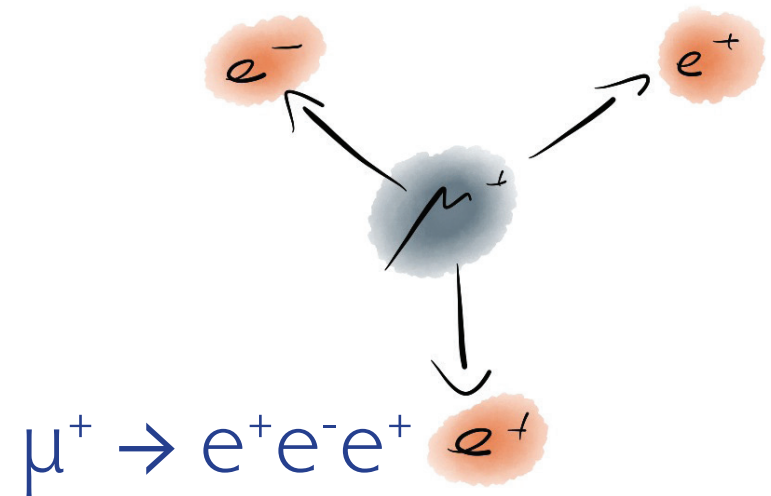
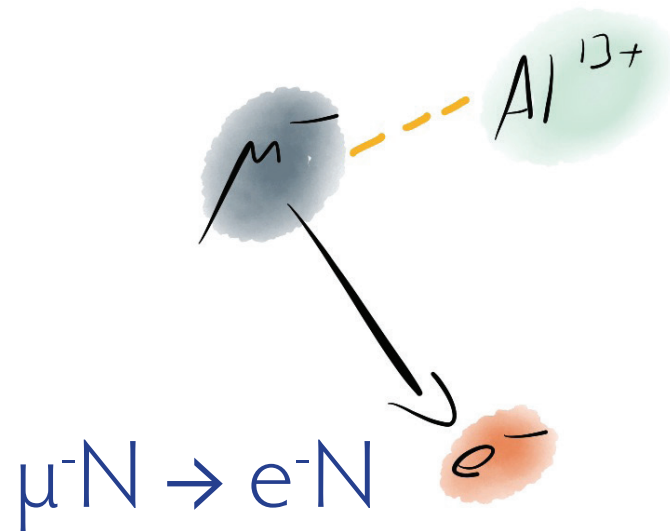
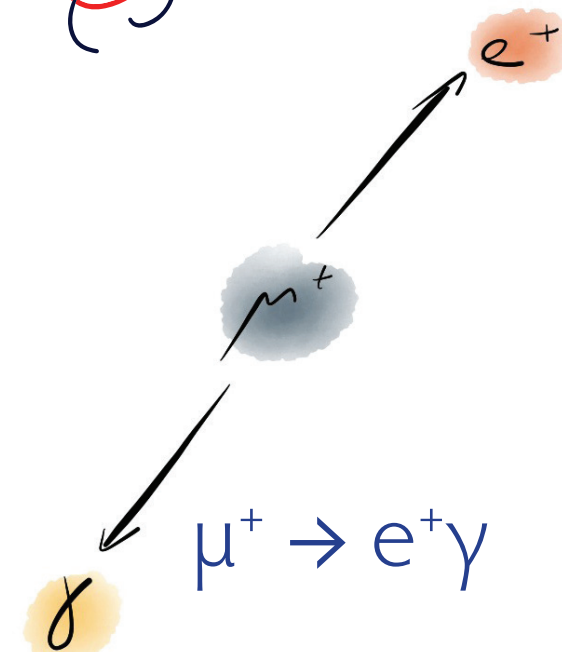

Kinematics

- 2-body decay
- Monoenergetic e^+ , γ
- Back-to-back

Kinematics

- Quasi 2-body decay
- Monoenergetic e^-
- Single particle detected

Kinematics

- 3-body decay
- Invariant mass constraint
- $\sum p_i = 0$

LFV Muon Decays: Experimental signatures

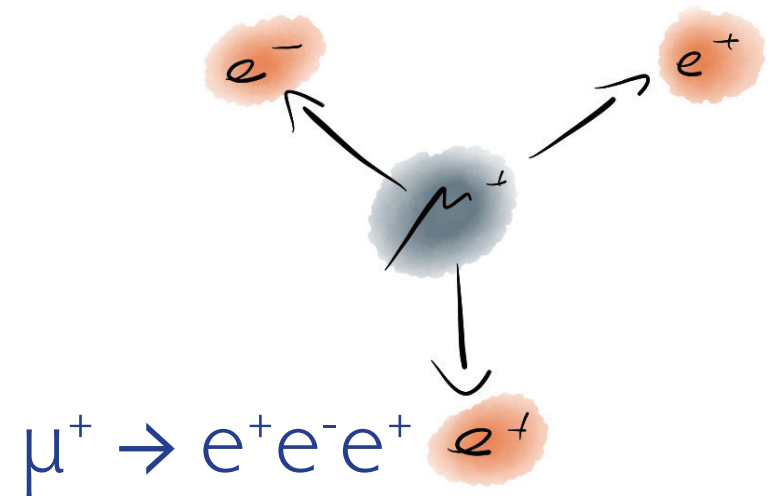
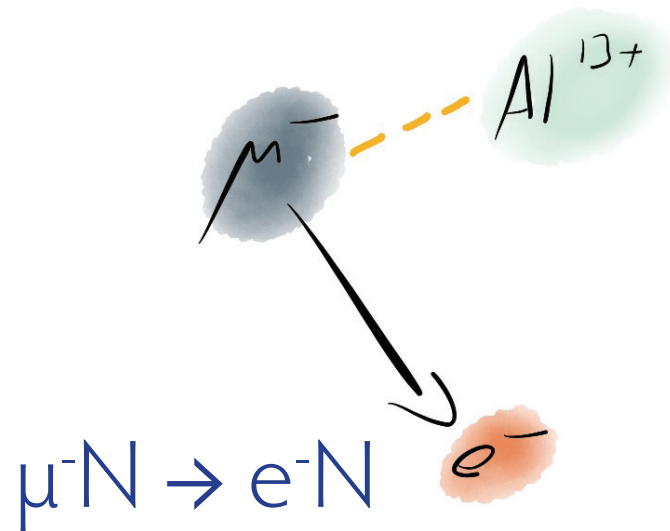
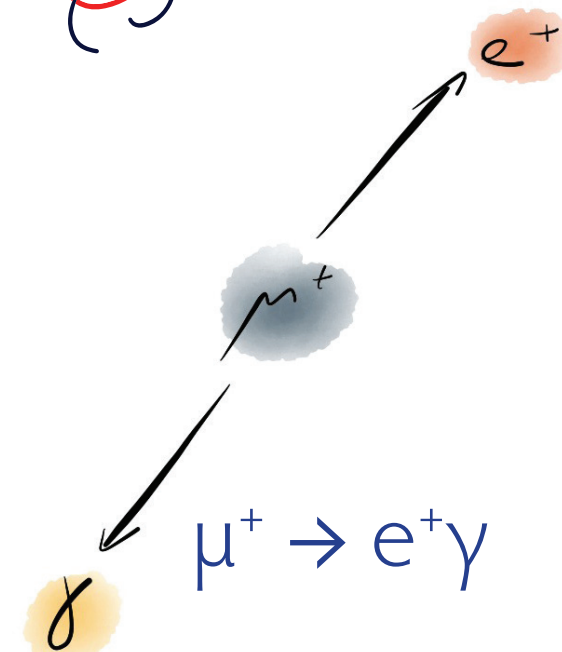

Kinematics

- 2-body decay
- Monoenergetic e^+ , γ
- Back-to-back

Background

- Accidental background

Kinematics

- Quasi 2-body decay
- Monoenergetic e^-
- Single particle detected

Background

- Decay in orbit
- Antiprotons, pions, cosmics

Kinematics

- 3-body decay
- Invariant mass constraint
- $\sum p_i = 0$

Background

- Radiative decay
- Accidental background

LFV Muon Decays: Experimental signatures

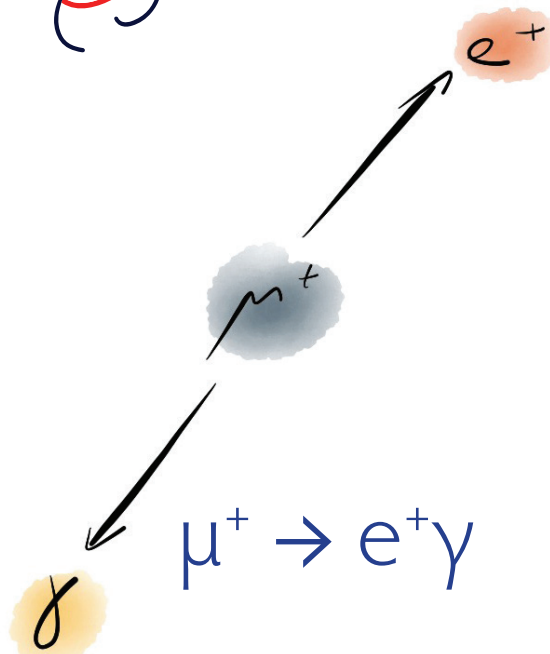

$$\mu^+ \rightarrow e^+ \gamma$$

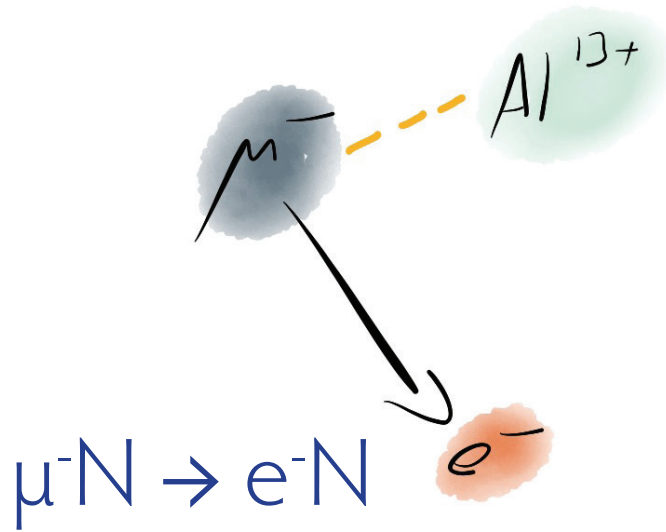

$$\mu^- N \rightarrow e^- N$$

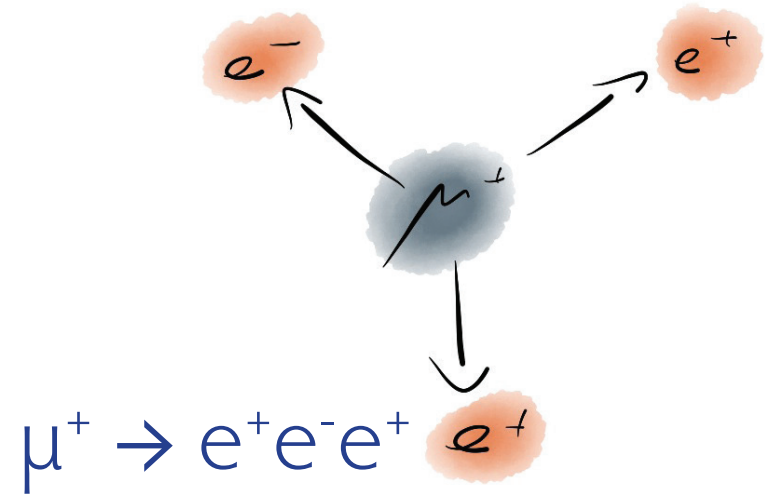

$$\mu^+ \rightarrow e^+ e^- e^+$$

Kinematics

- 2-body decay
- Monoenergetic
- Back-to-back

Background

- Atomic background

Continuous Beam

Kinematics

- Quasi 2-body decay
- Monoenergetic
- Single particle detected

Background

- Γ orbit
- Atomic protons, pions

Pulsed Beam

Kinematics

- 3-body decay
- Invariant mass constraint
- $\sum p_i = 0$

Background

- Radiative decay
- Atomic background

Continuous Beam



Searching for
 $\mu^+ \rightarrow e^+e^-e^+$ at the 10^{-16} level



The Goal: 10^{-16}

- We want to find or exclude $\mu \rightarrow eee$ at the 10^{-16} level

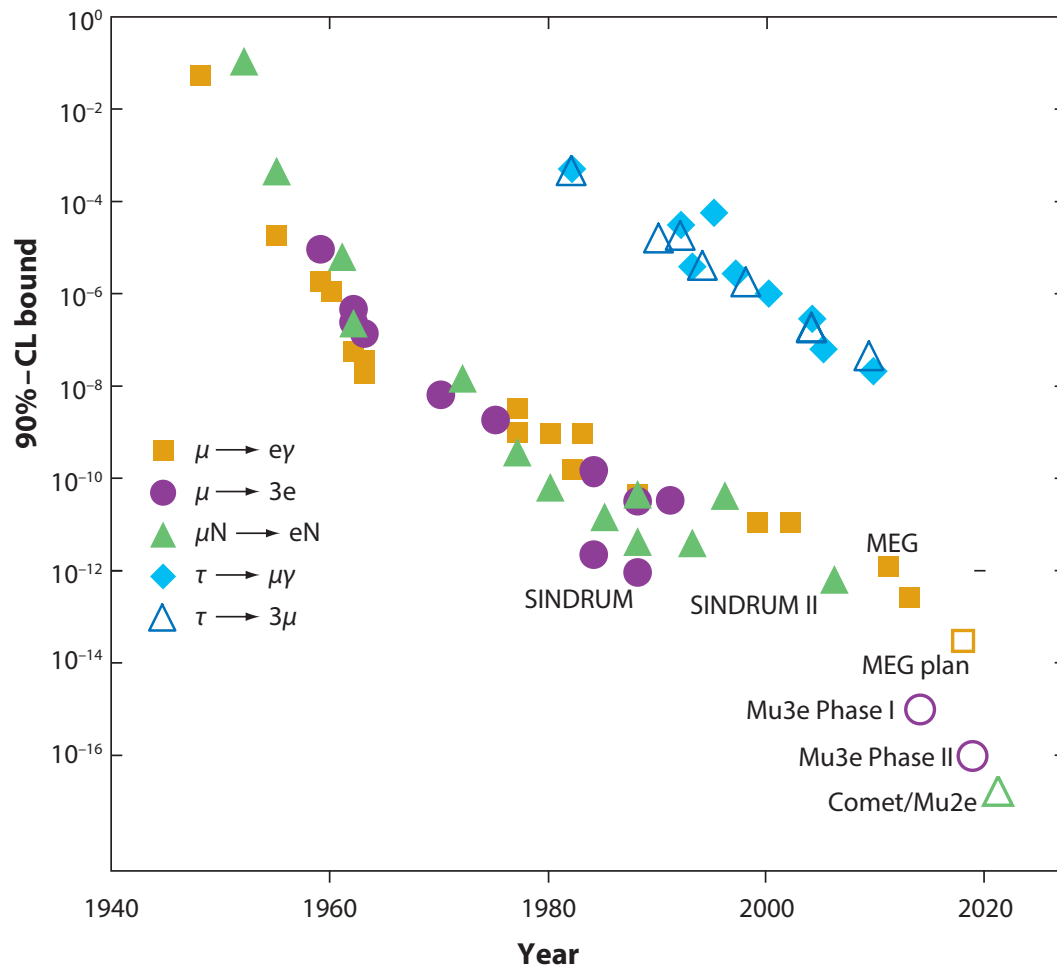

- 10^{-15} in phase I (existing beamline)
- 10^{-16} in phase II (new beamline)
- 4 orders of magnitude over previous experiment (SINDRUM 1988)

(Updated from W.J. Marciano, T. Mori and J.M. Roney, *Ann.Rev.Nucl.Part.Sci.* 58, 315 (2008))



The Mu3e Collaboration



**UNIVERSITÉ
DE GENÈVE**

- DPNC, Geneva University



- Physics Institute, Heidelberg University



- KIP, Heidelberg University

ziti

ZITI Mannheim, Heidelberg University

PAUL SCHERRER INSTITUT
PSI

- Paul Scherrer Institute



- Physics Institute, Zürich University

ETH

Eidgenössische Technische Hochschule Zürich
Swiss Federal Institute of Technology Zurich

- Institute for Particle Physics, ETH Zürich



The Challenges

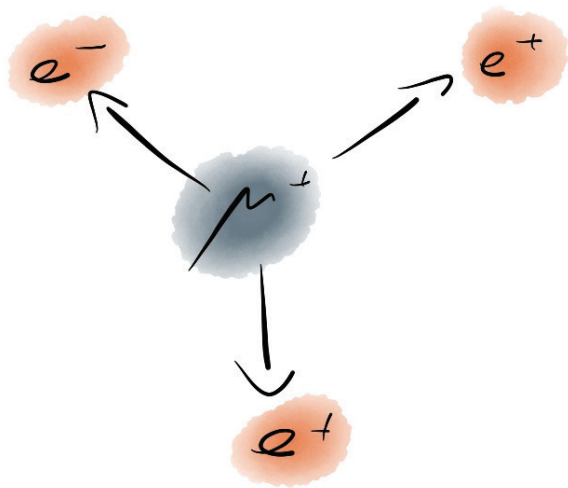

- Observe more than 10^{16} muon decays:
2 Billion muons per second
- Suppress backgrounds by more than 16 orders of magnitude
- Be sensitive for the signal



Muons from PSI

DC muon beams at PSI:

- $\pi E5$ beamline: $\sim 10^8$ muons/s
(MEG experiment, Mu3e phase I)



Ekramer 10-99



Muons from PSI

DC muon beams at PSI:

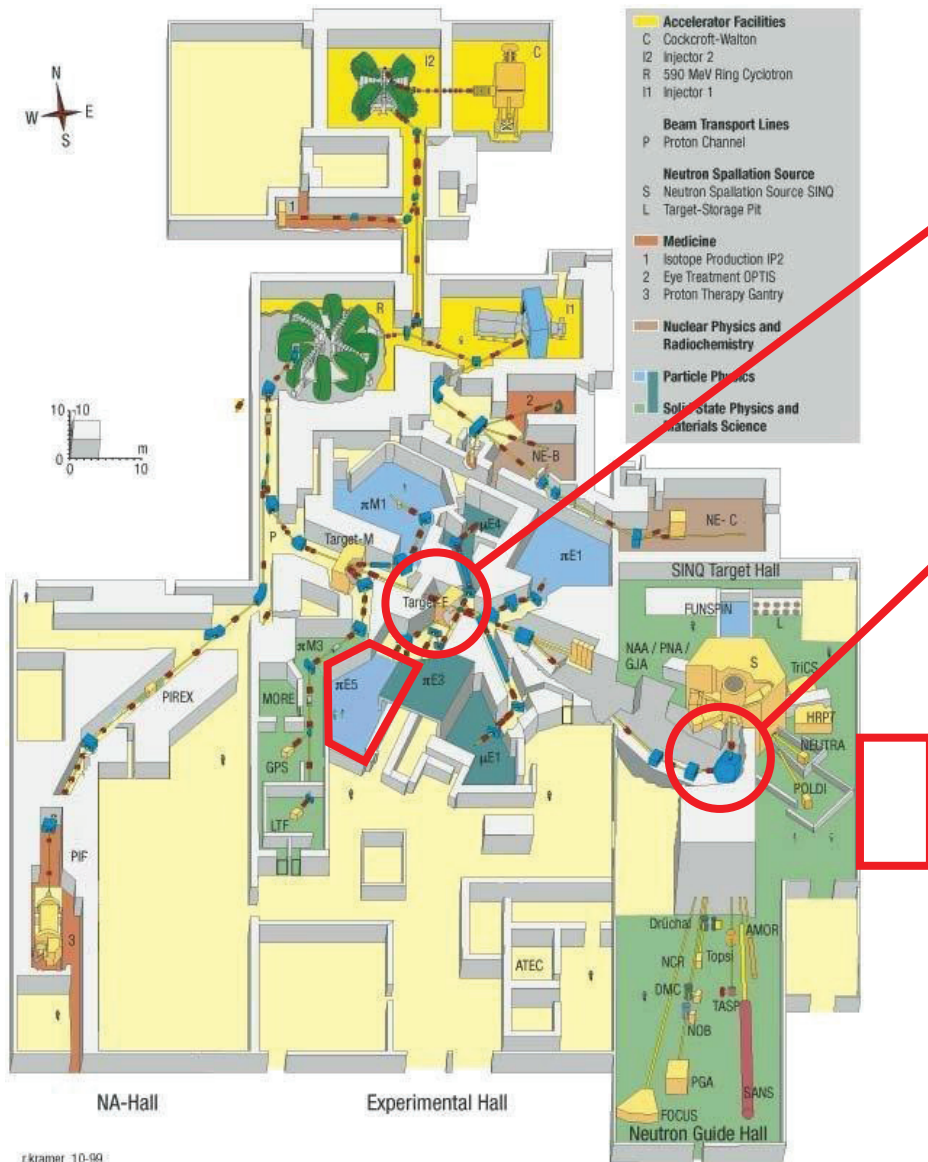

- $\pi E5$ beamline: $\sim 10^8$ muons/s
(MEG experiment, Mu3e phase I)
- At the SINQ (spallation neutron source) more than $\sim 5 \times 10^{10}$ muons/s are produced
High intensity muon beamline (HiMB) proposal
- The $\mu \rightarrow eee$ experiment (final stage) requires 2×10^9 muons/s focused and collimated on a ~ 2 cm spot



The High-Intensity Muon Beamline (HIMB)

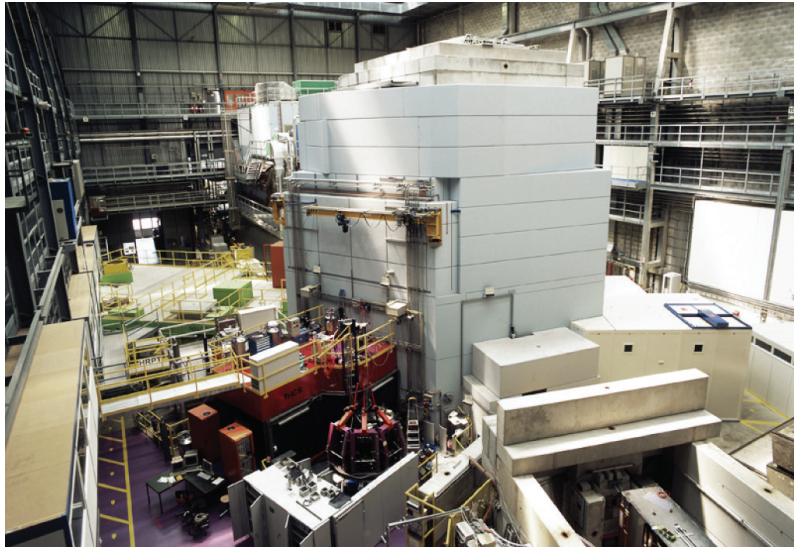

- Muon rates in excess of $10^{10}/s$
- $2 \cdot 10^9/s$ needed for $\mu \rightarrow eee$ at 10^{-16}
- Not before 2019

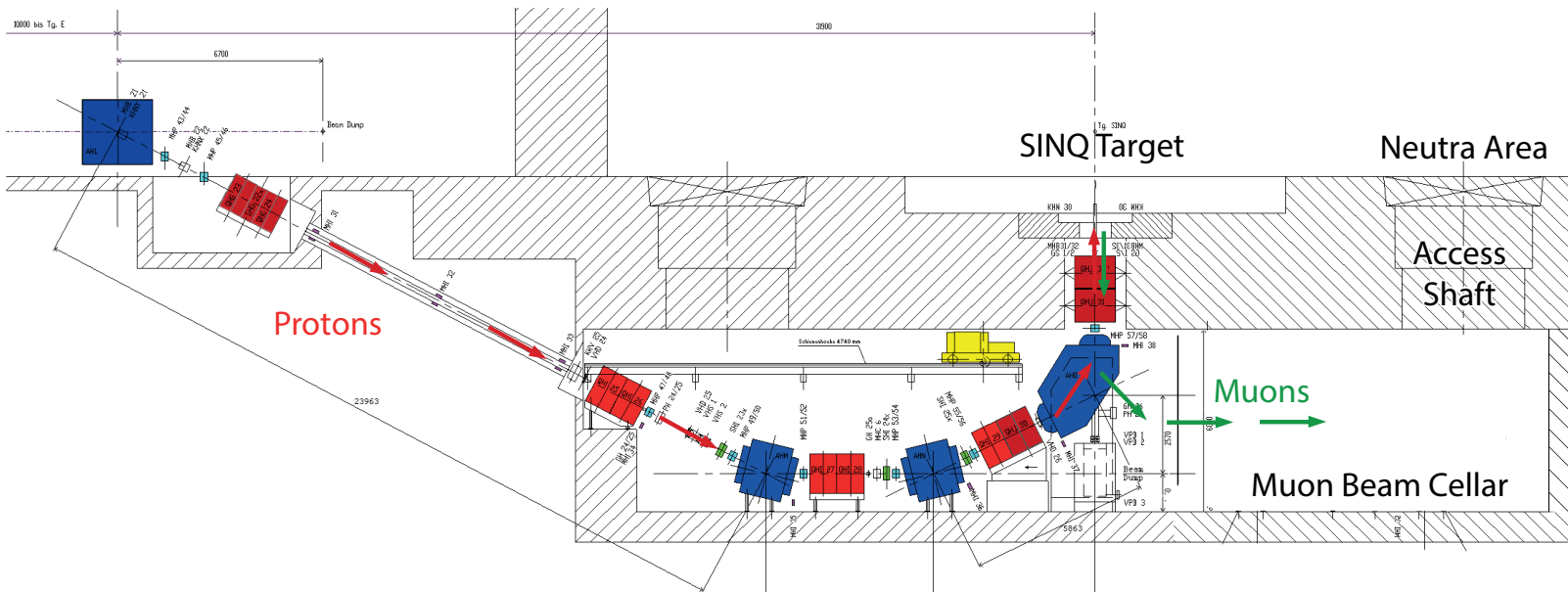
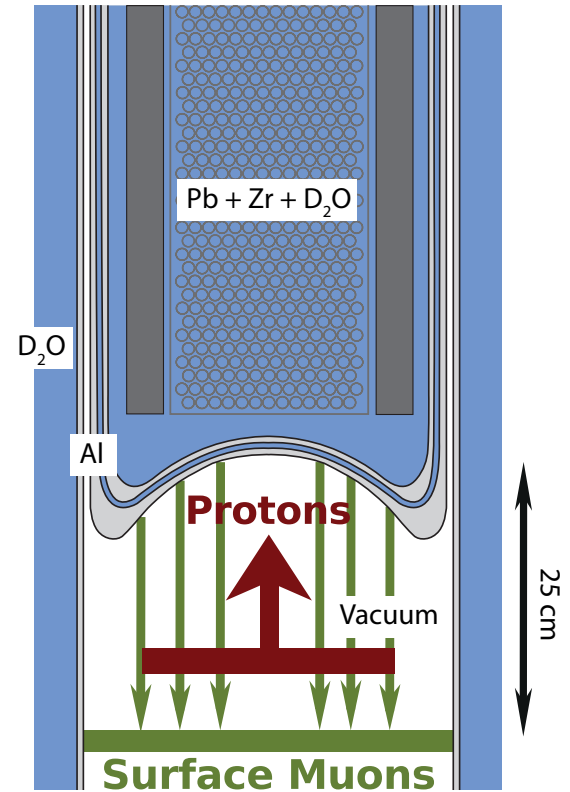



The signal

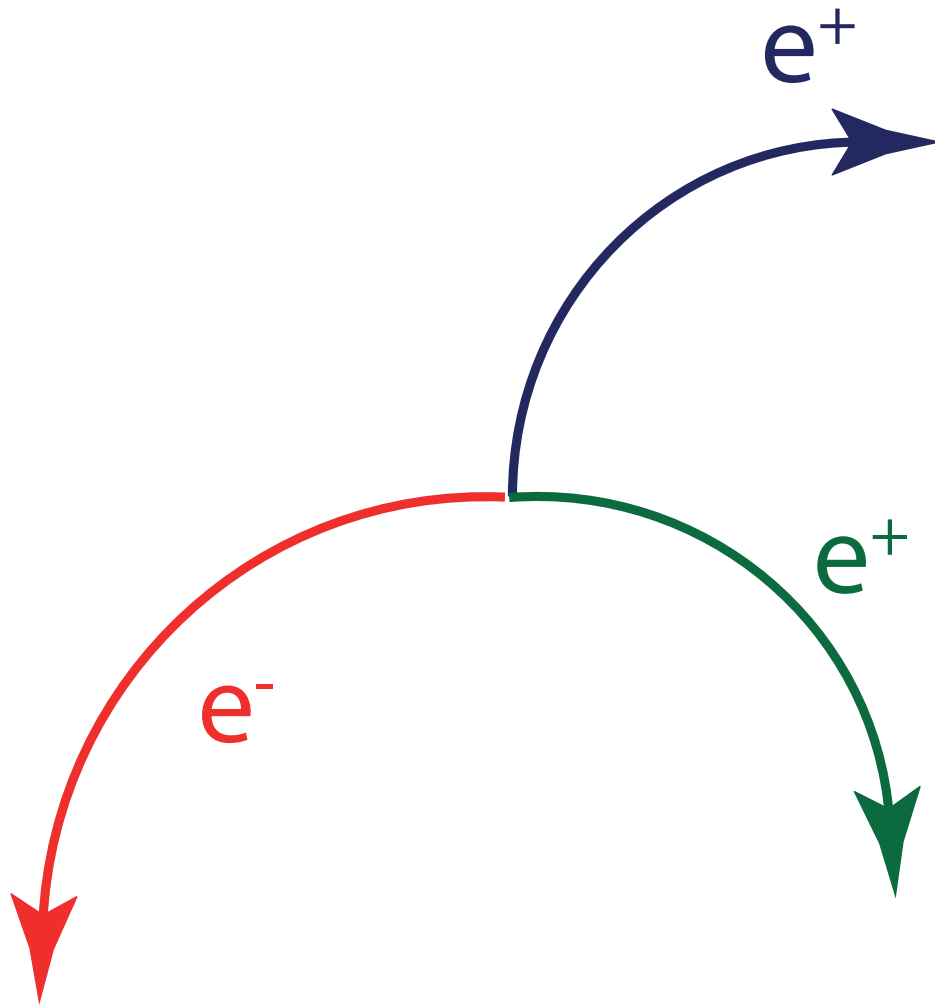

- $\mu^+ \rightarrow e^+e^-e^+$
- Two positrons, one electron
- From same vertex
- Same time
- Sum of 4-momenta corresponds to muon at rest
- Maximum momentum: $\frac{1}{2} m_\mu = 53 \text{ MeV}/c$



Accidental Background

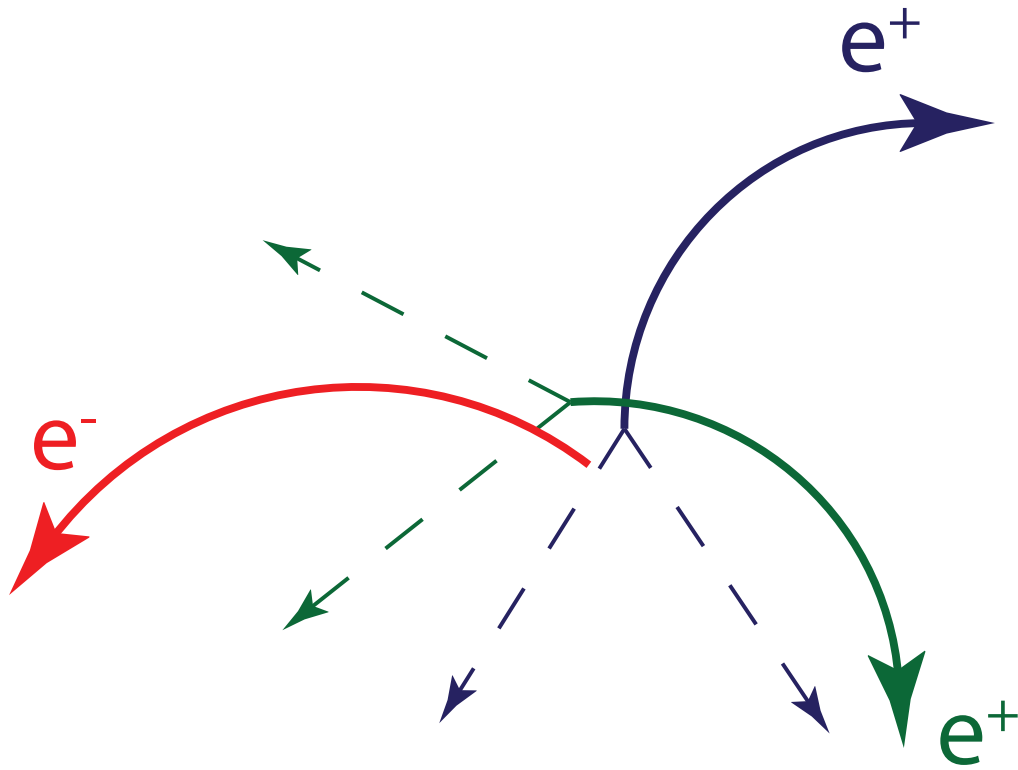

- Combination of positrons from ordinary muon decay with electrons from:
 - photon conversion,
 - Bhabha scattering,
 - Mis-reconstruction
- Need very good timing, vertex and momentum resolution

Internal conversion background

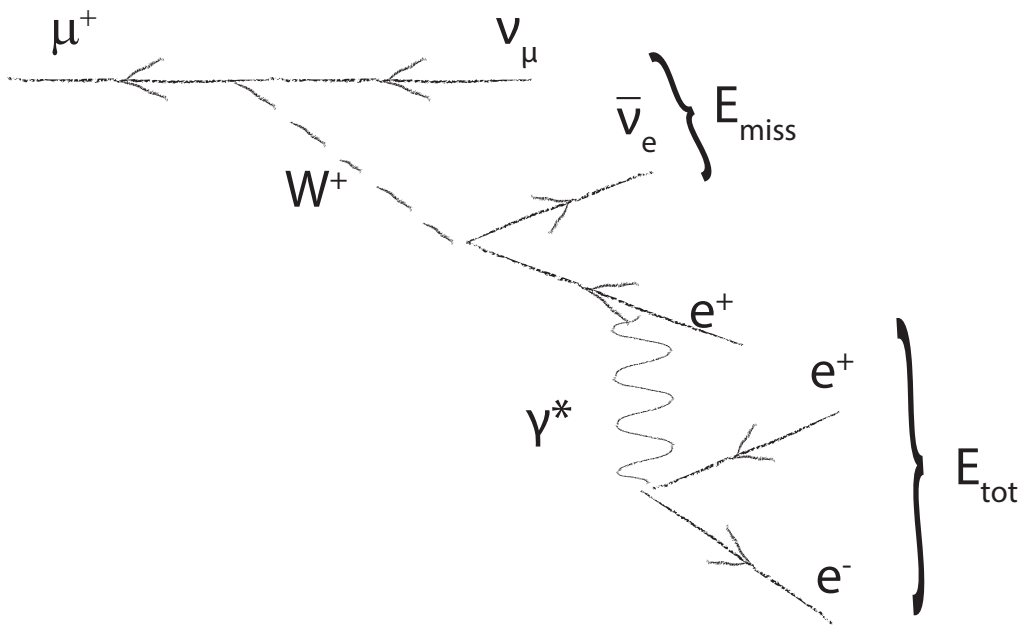

- Allowed radiative decay with internal conversion:



- Only distinguishing feature:
Missing momentum carried by neutrinos

- Need excellent momentum resolution

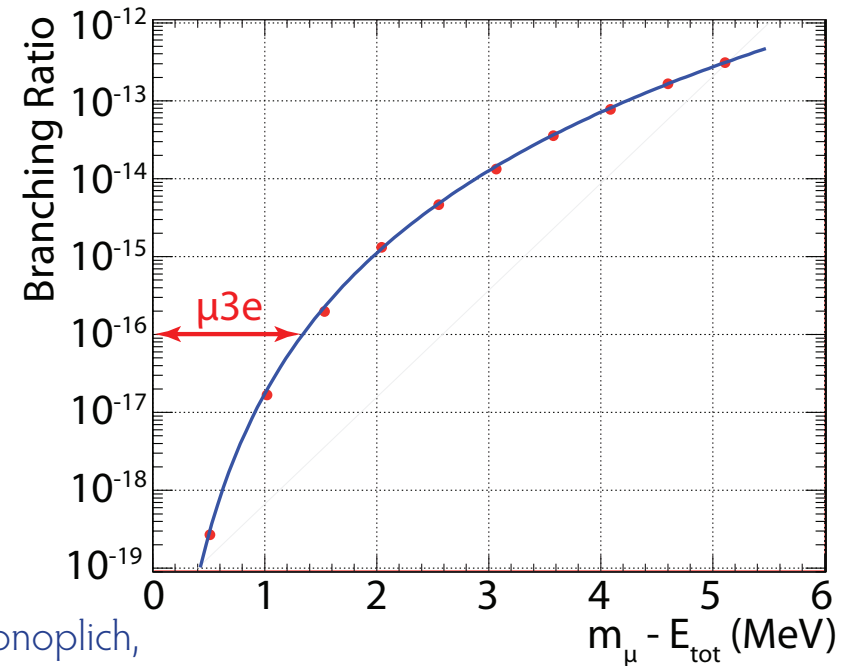

(R. M. Djilkibaev, R. V. Konoplich,
Phys.Rev. D79 (2009) 073004)



Building the Mu3e Experiment



2 Billion Muons/s

muon beam

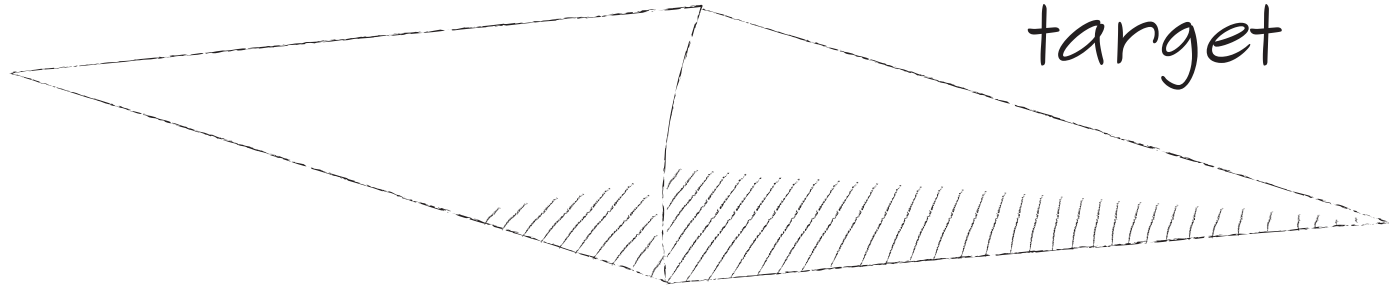
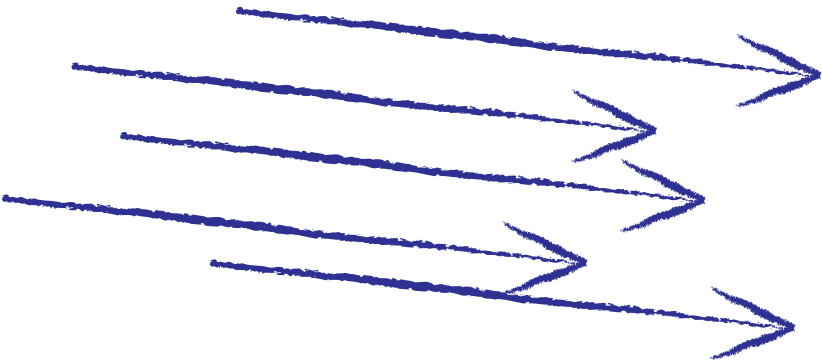

target



2 Billion Muon Decays/s

50 ns, 1 Tesla field

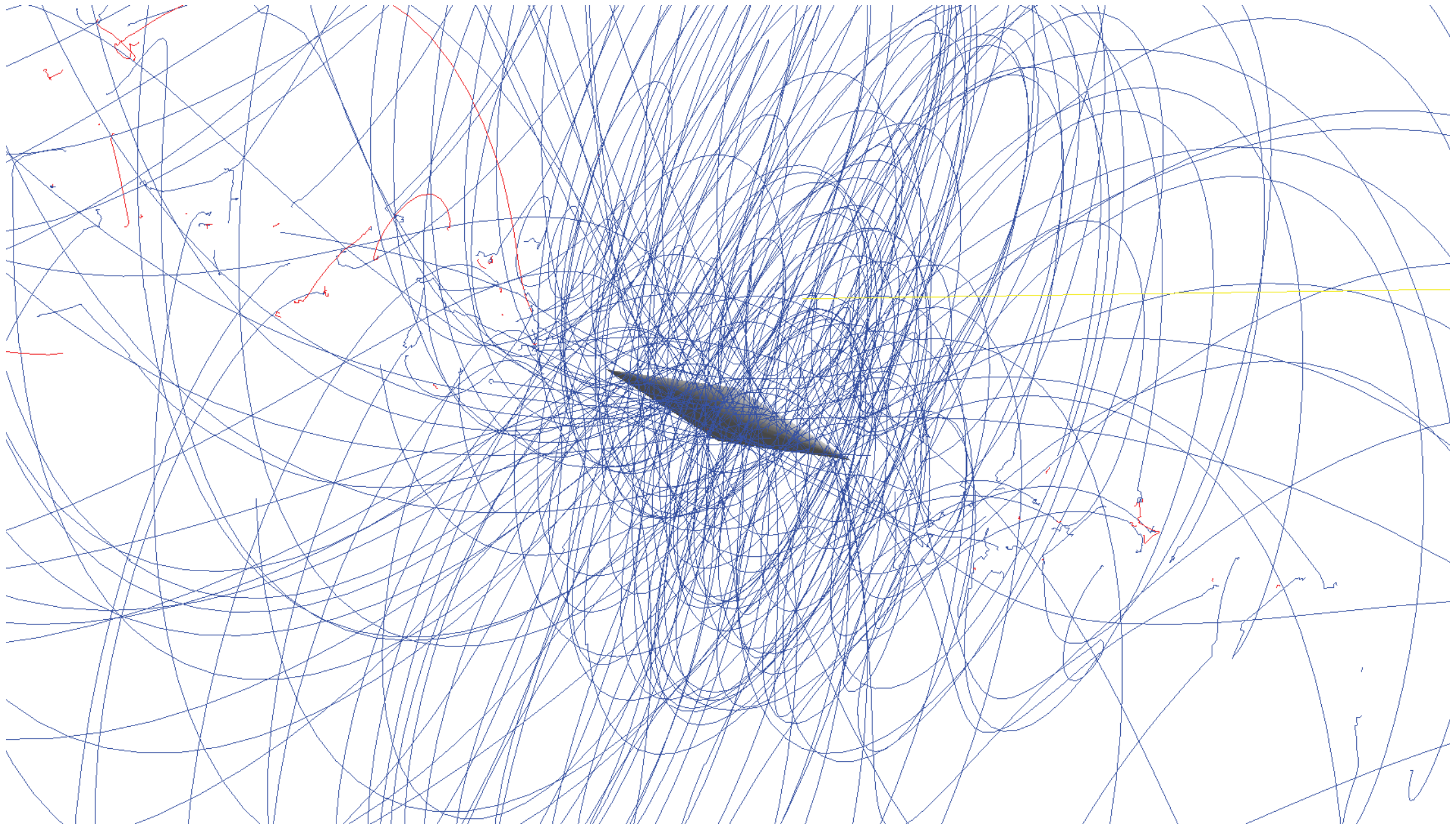



Detector Technology

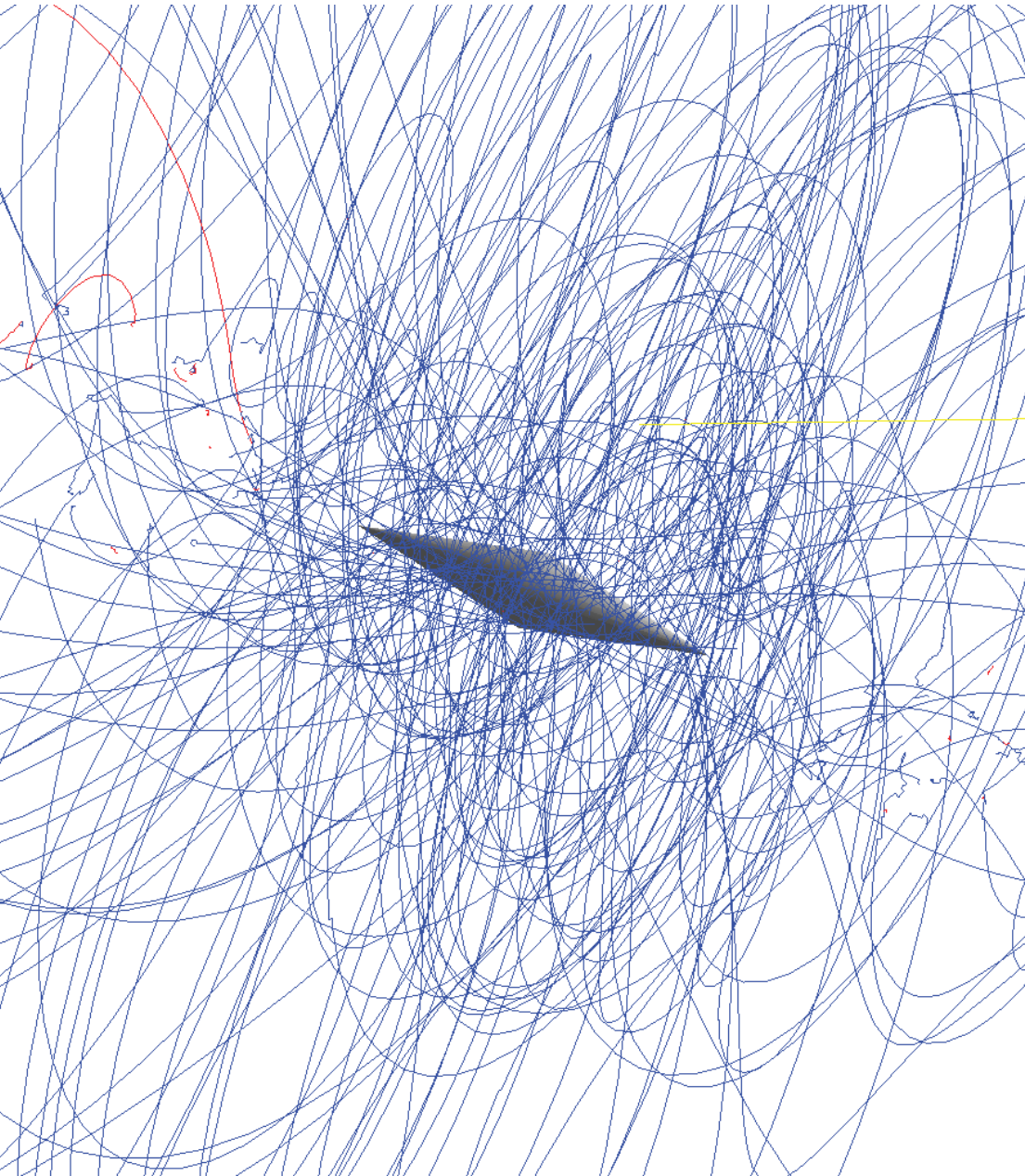

- High granularity (occupancy)
- Close to target (vertex resolution)
- 3D space points (reconstruction)
- Minimum material (momenta below 53 MeV/c)
- Gas detectors do not work (space charge, aging, 3D)
- Silicon strips do not work (material budget, 3D)
- Hybrid pixels (as in LHC) do not work (material budget)



Fast and thin sensors: HV-MAPS

High voltage monolithic active pixel sensors

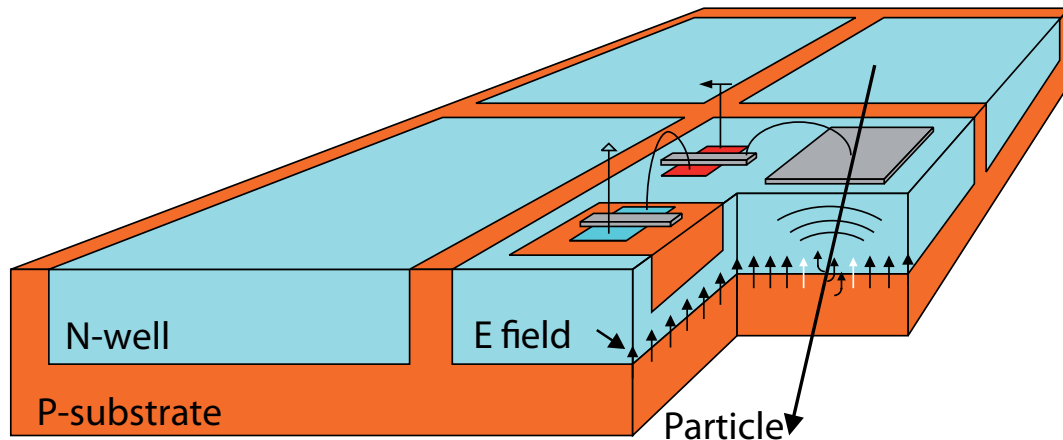

- Use a high voltage commercial process (automotive industry)
- Small active region, fast charge collection via drift
- Implement logic directly in N-well in the pixel - smart diode array
- Can be thinned down to $< 50 \mu\text{m}$
- Logic on chip: Output are zero-suppressed hit addresses and timestamps

(I.Peric, P. Fischer et al., NIM A 582 (2007) 876)



The MUIPX chip prototypes

MUIPX2

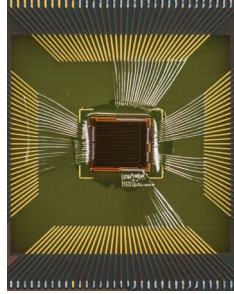
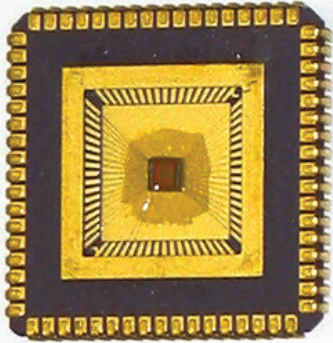

MUIPX6

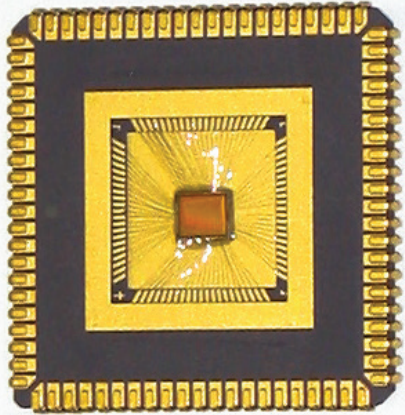

MUIPX4

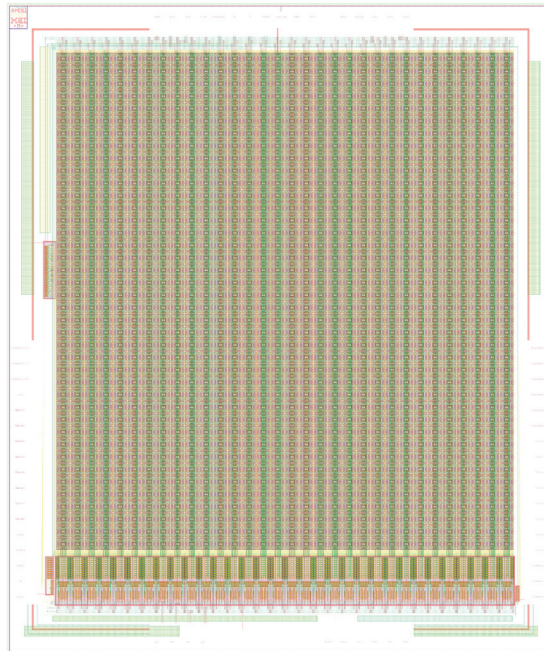

HV-MAPS chips: AMS 180 nm HV-CMOS

- 5 generations of prototypes
- Current generation:
MUIPX6
40 x 32 pixels
80 x 103 μm pixel size
9.4 mm^2 active area
- Test beam results with **MUIPX4**
- **MUIPX7** (August submission) will have all features of final sensor
- Left to do: Scale to 1 x 2 and 2 x 2 cm^2



Test beam at DESY

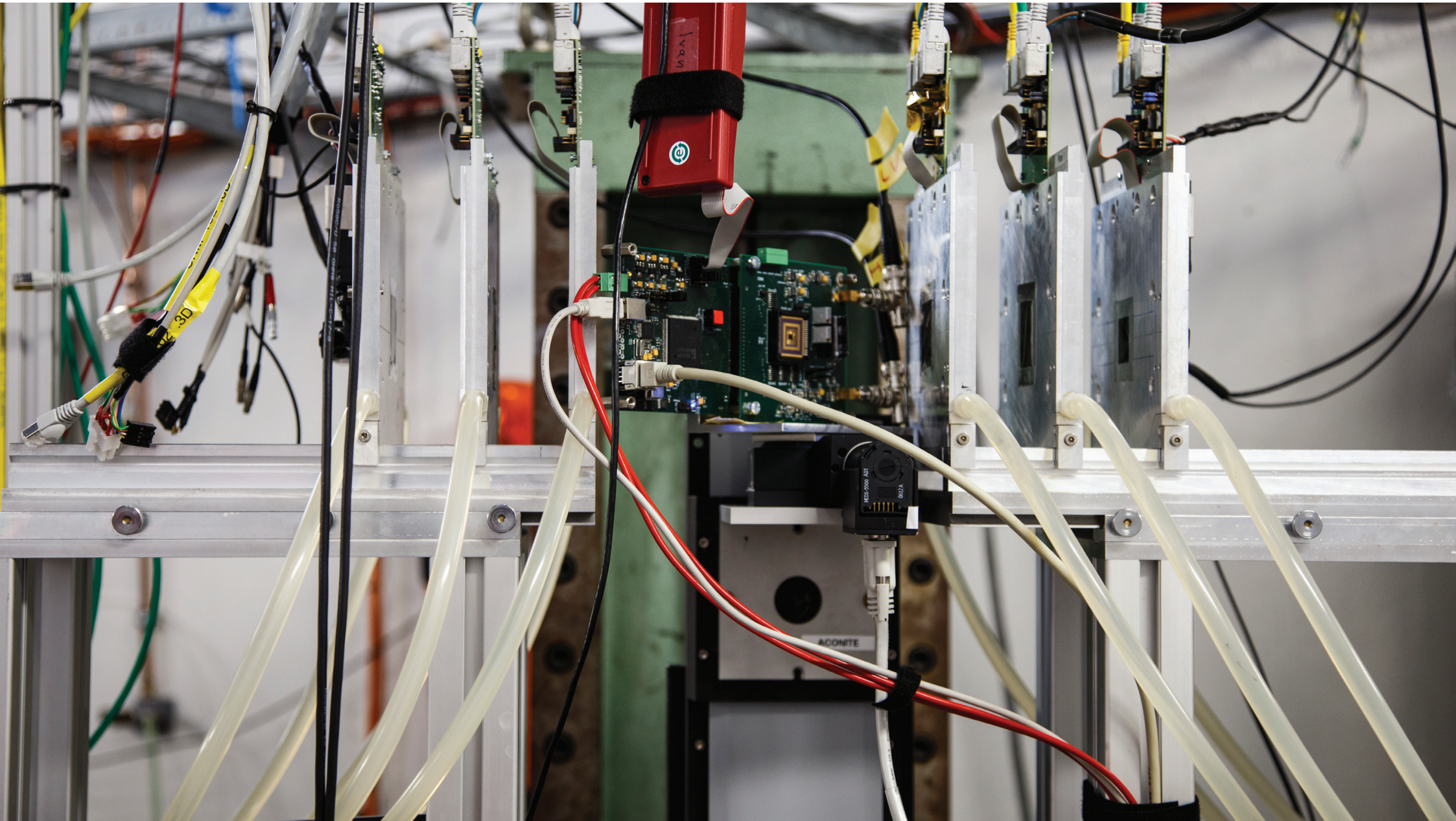



Position Resolution

Position resolution given by pixel size

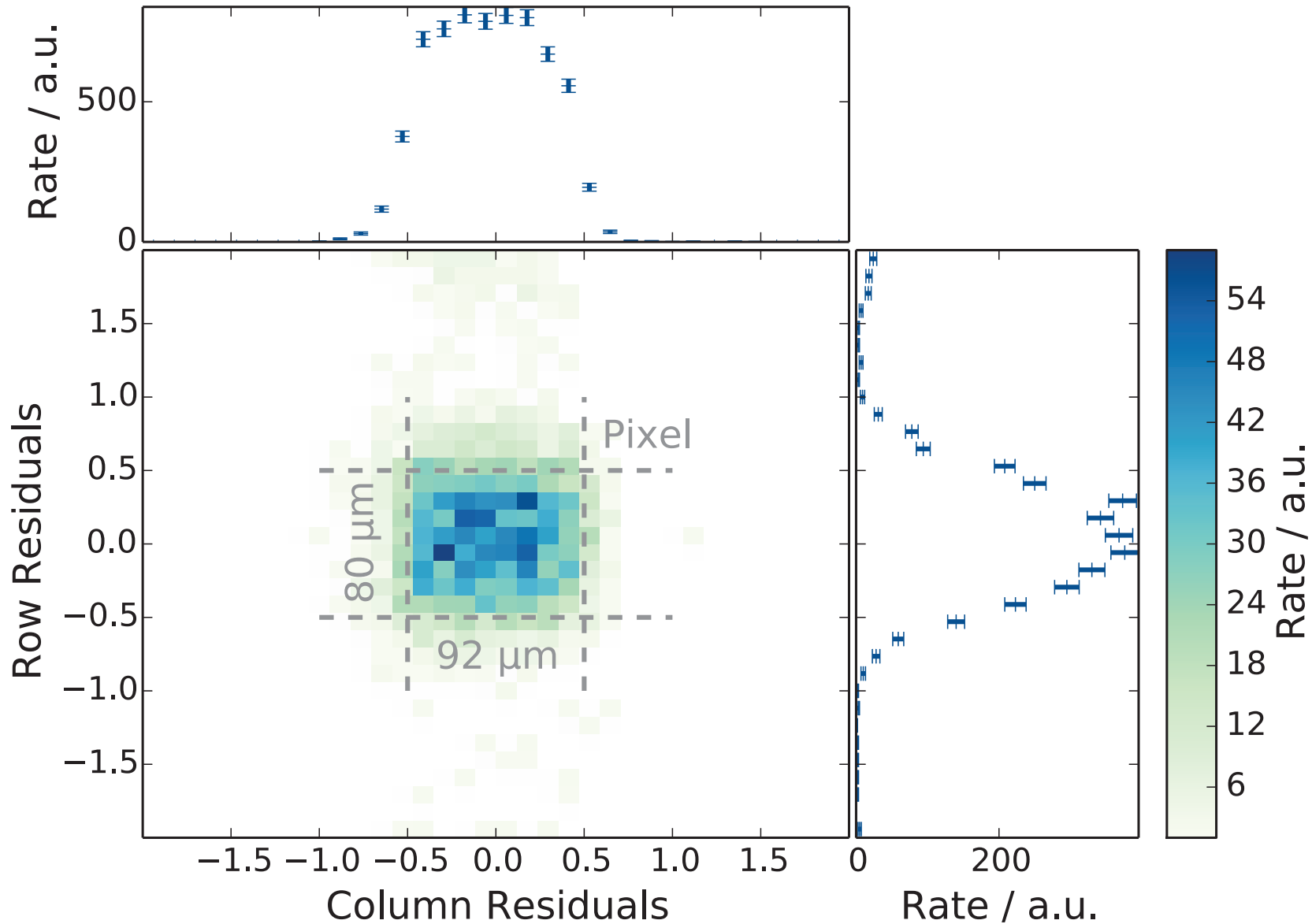



Efficiency

Hit efficiency above 99% without tuning

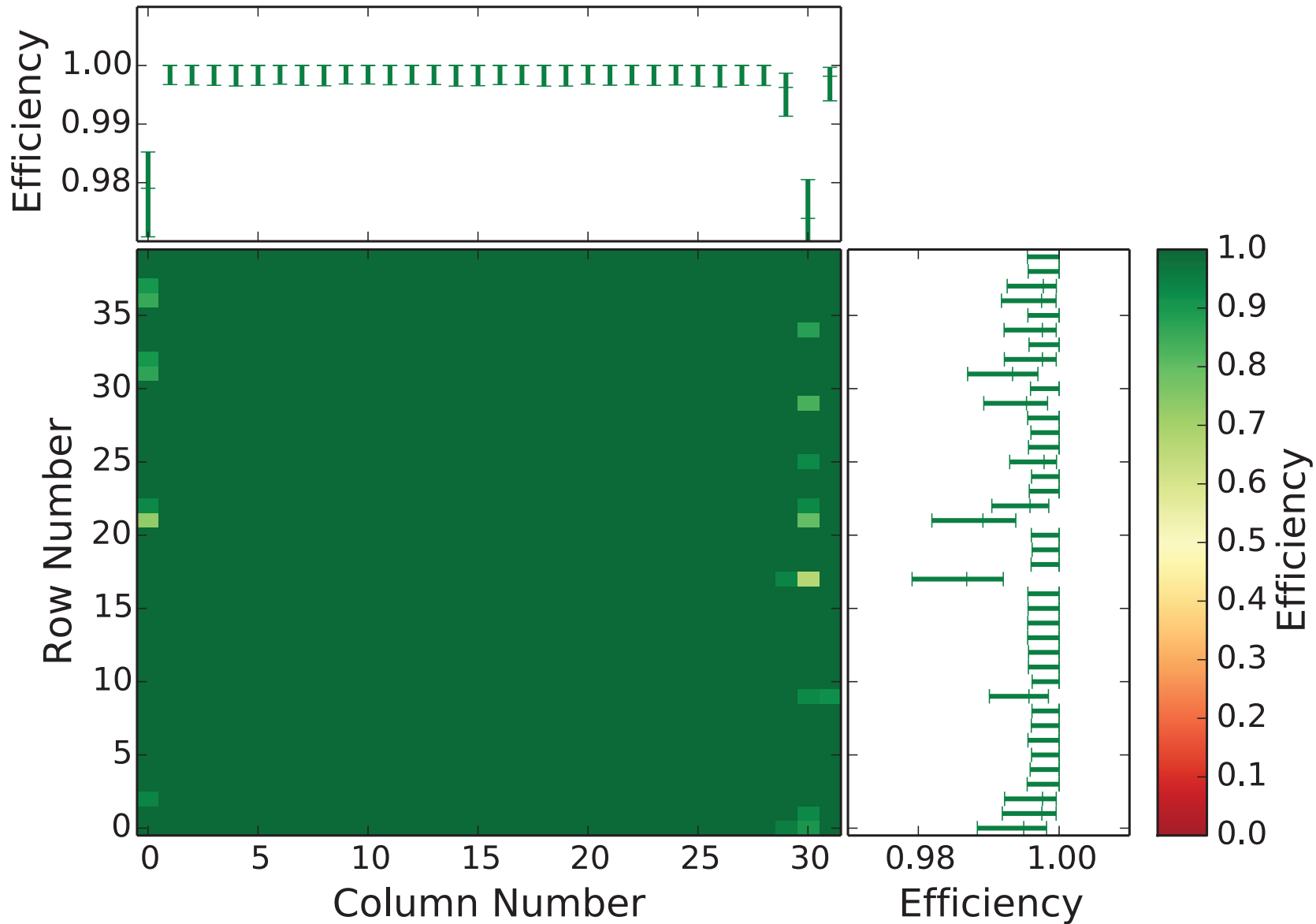



Time resolution

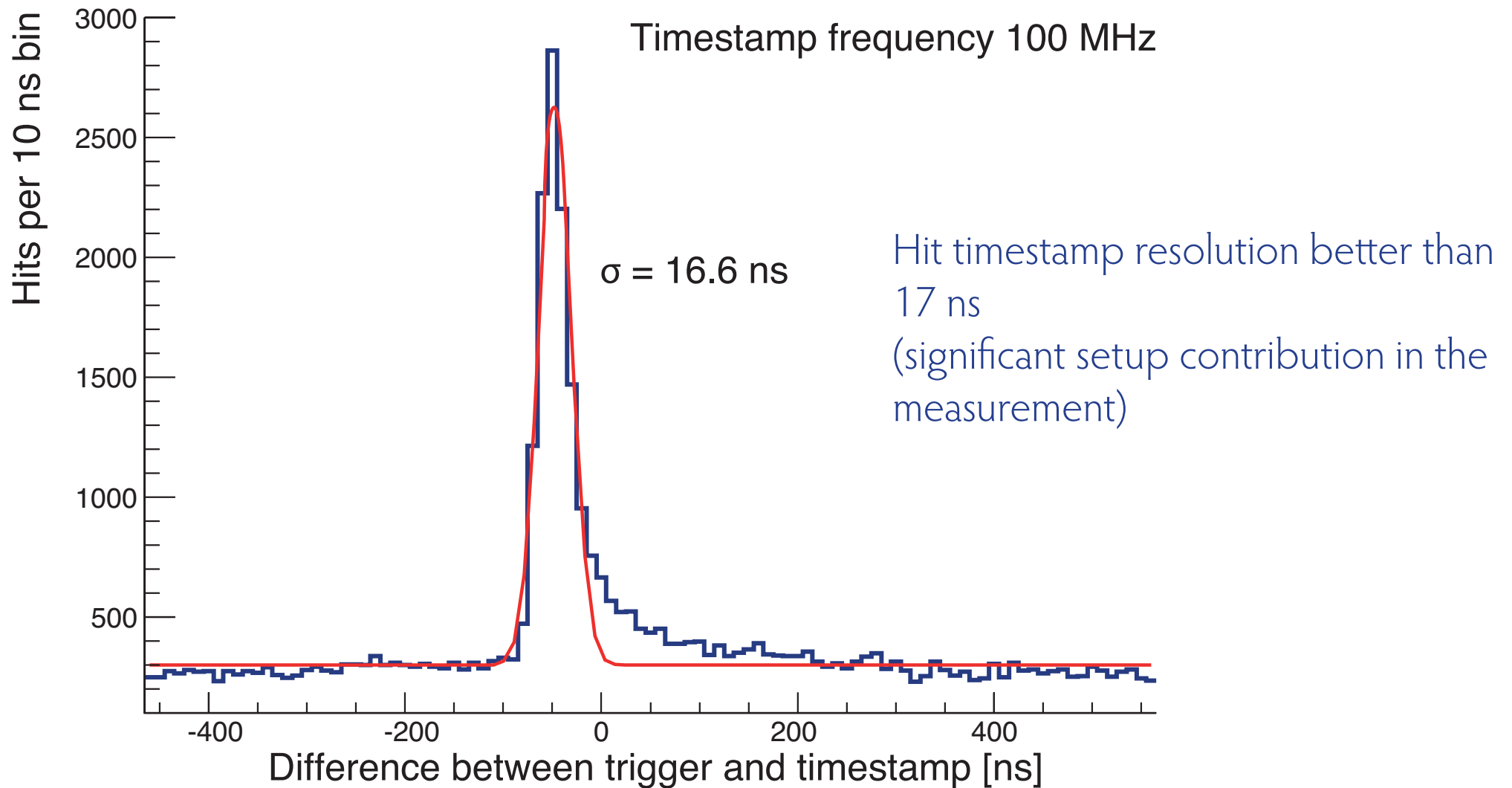



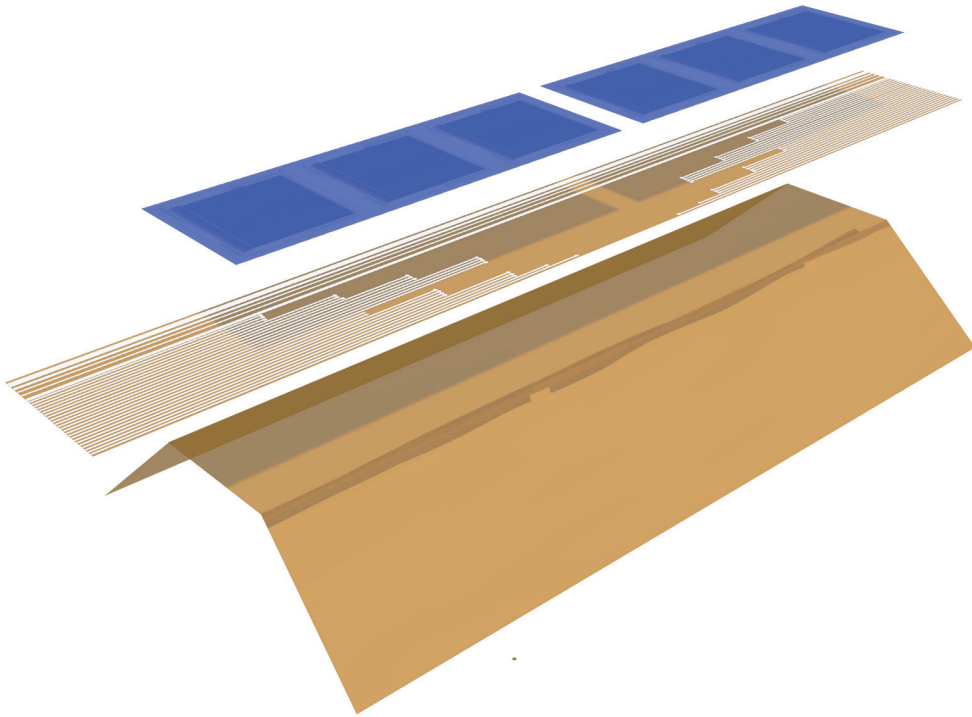

- 50 μm silicon
- 25 μm Kapton™ flexprint with aluminium traces
- 25 μm Kapton™ frame as support
- Less than 1‰ of a radiation length per layer



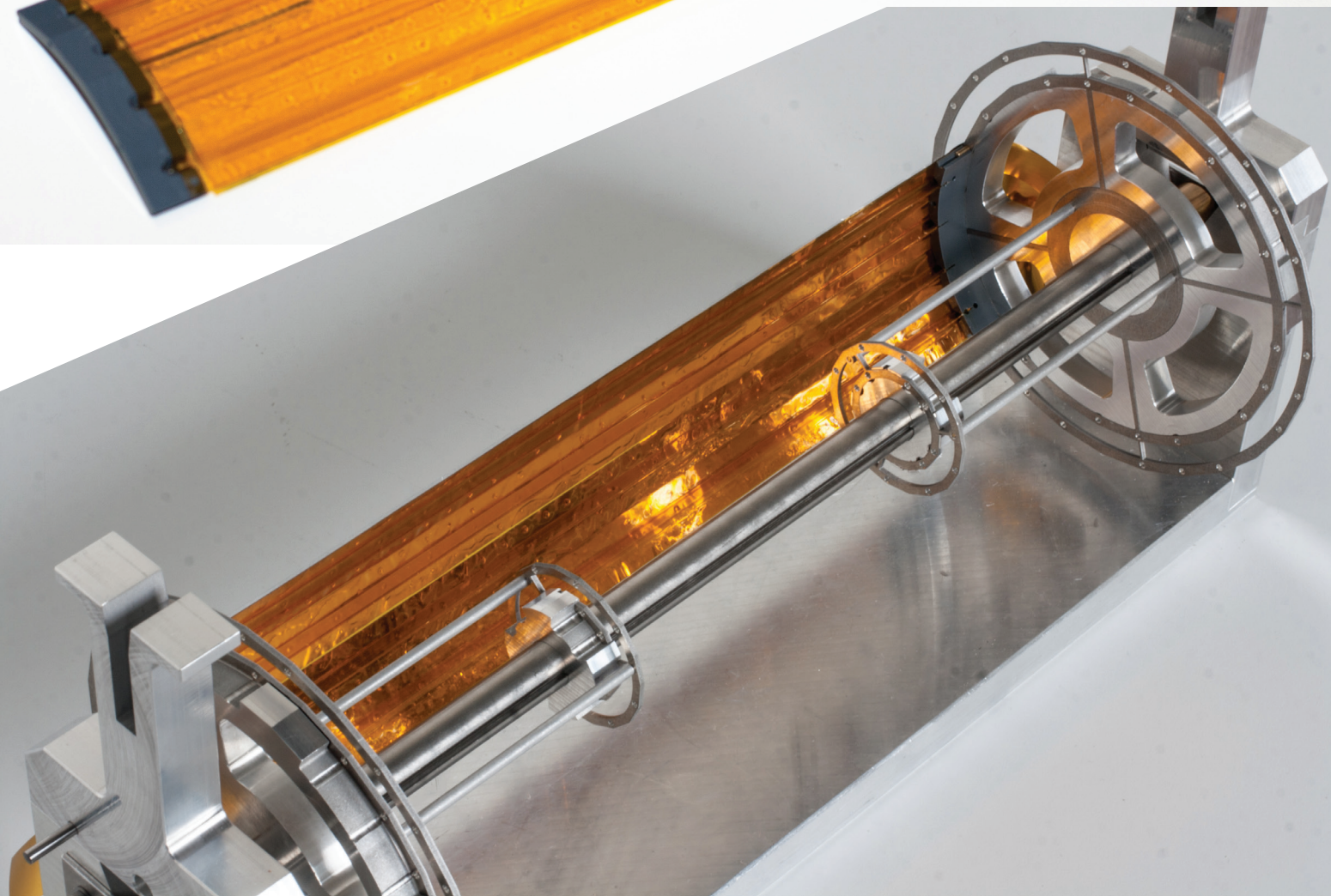

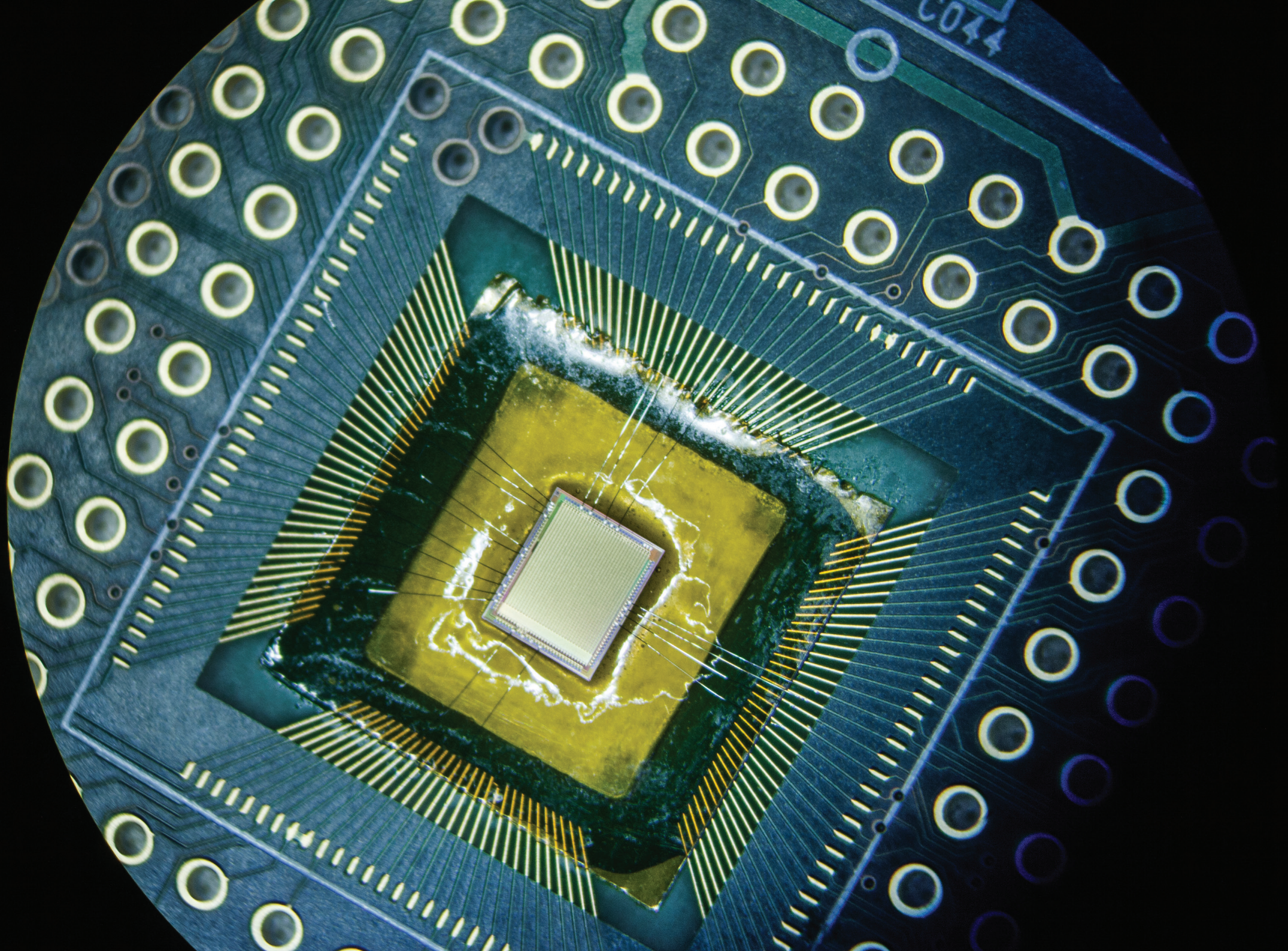

Cooling

- Add no material:
Cool with **gaseous Helium**
(low scattering, high mobility)
- $\sim 150 \text{ mW/cm}^2$ - total 2 kW
- Simulations: Need \sim **several m/s flow**

- Full scale heatable prototype built
- 36 cm active length
- No visible vibrations

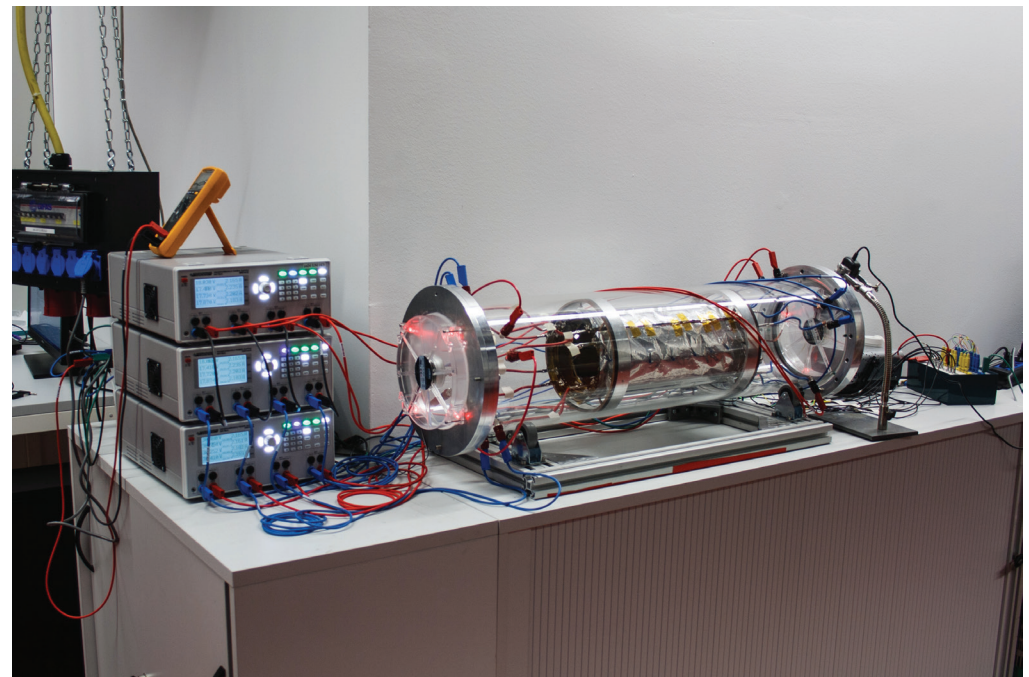
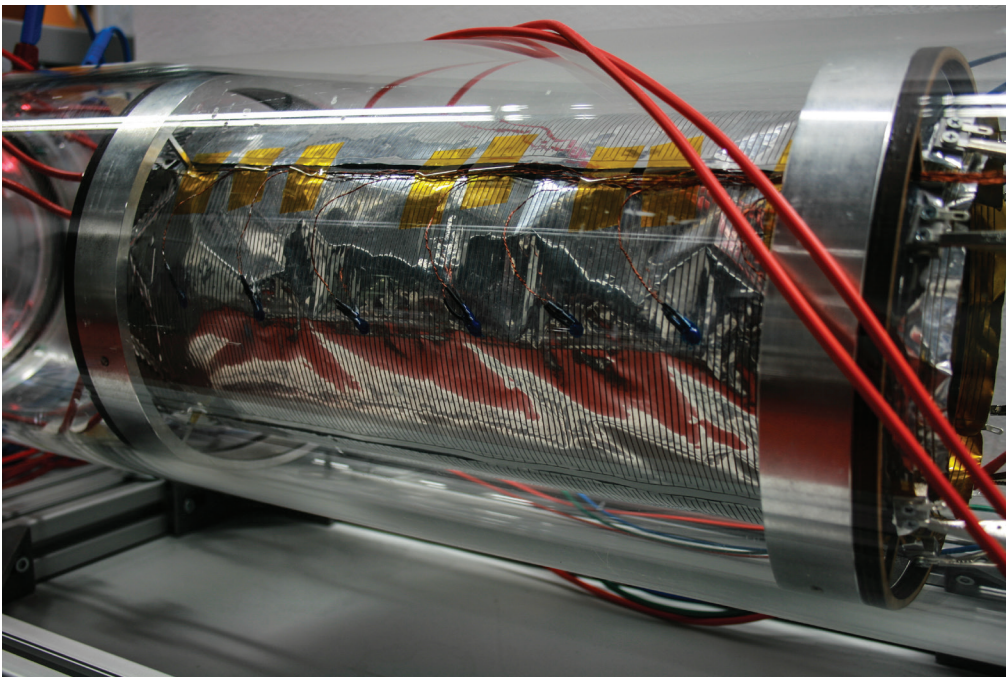



Cooling tests

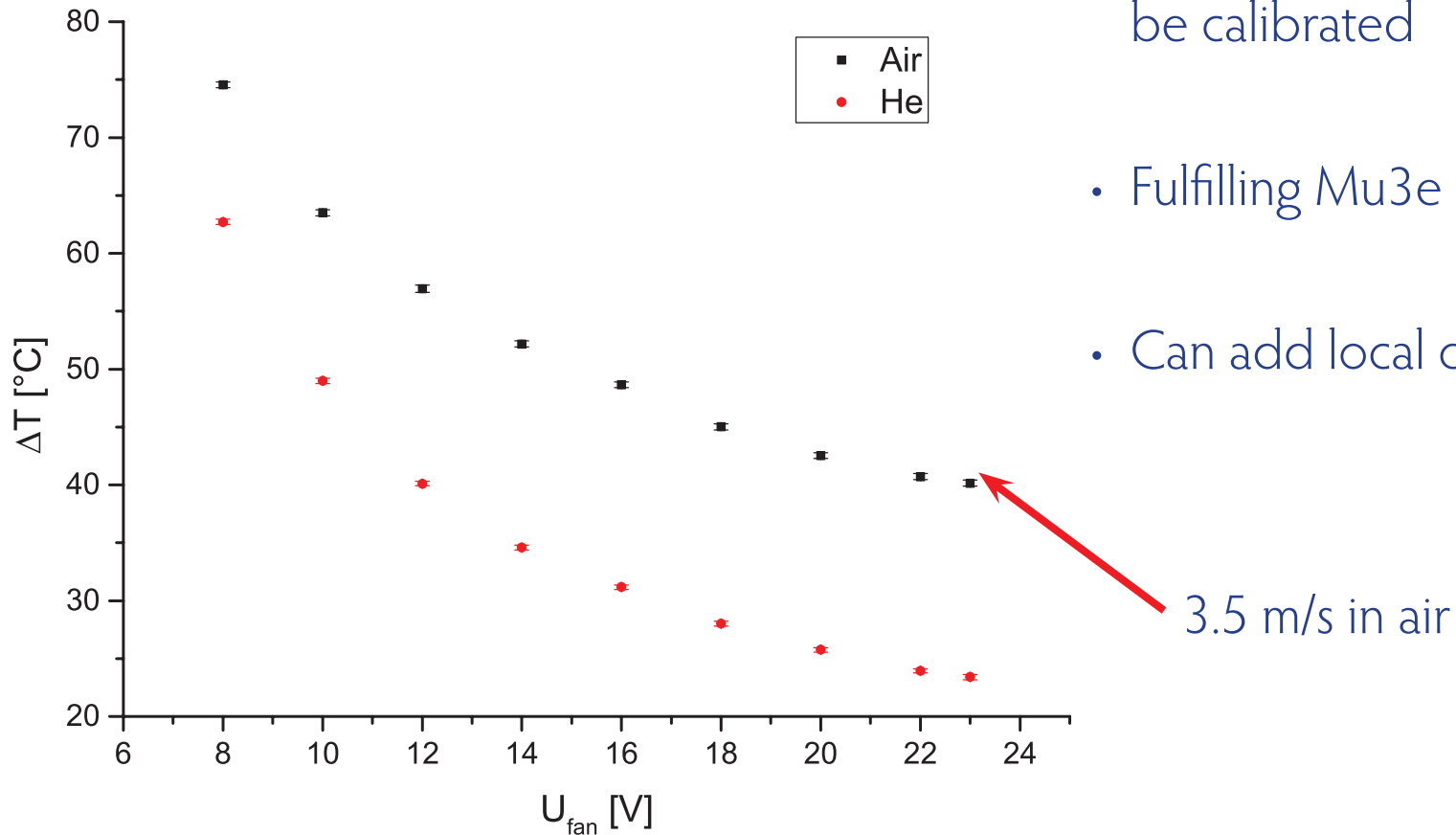

- Can keep gradients under 30°C over 36 cm with helium cooling
- Helium flow speed still needs to be calibrated
- Fulfilling Mu3e specs
- Can add local cooling

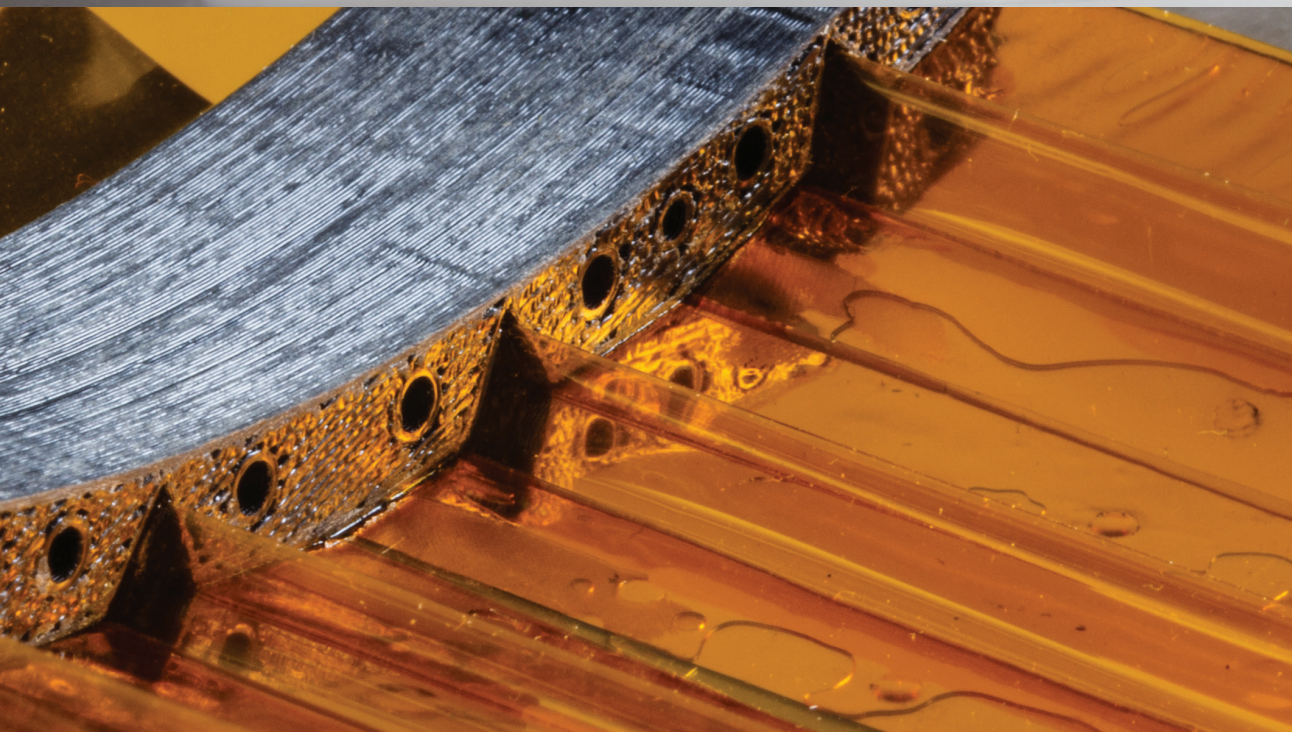



Momentum measurement

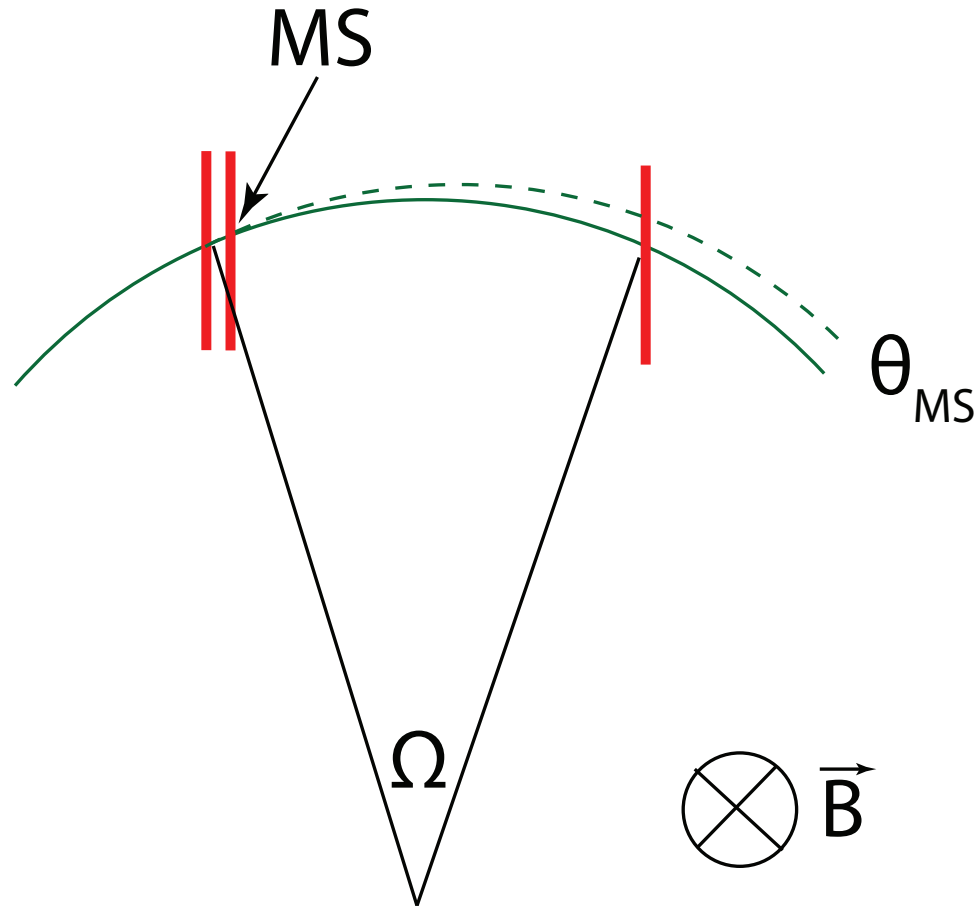

- 1 T magnetic field
- Resolution dominated by **multiple scattering**
- Momentum resolution to first order:

$$\sigma_{P/P} \sim \theta_{MS}/\Omega$$

- Precision requires large lever arm (large bending angle Ω) and low multiple scattering θ_{MS}

Precision vs. Acceptance

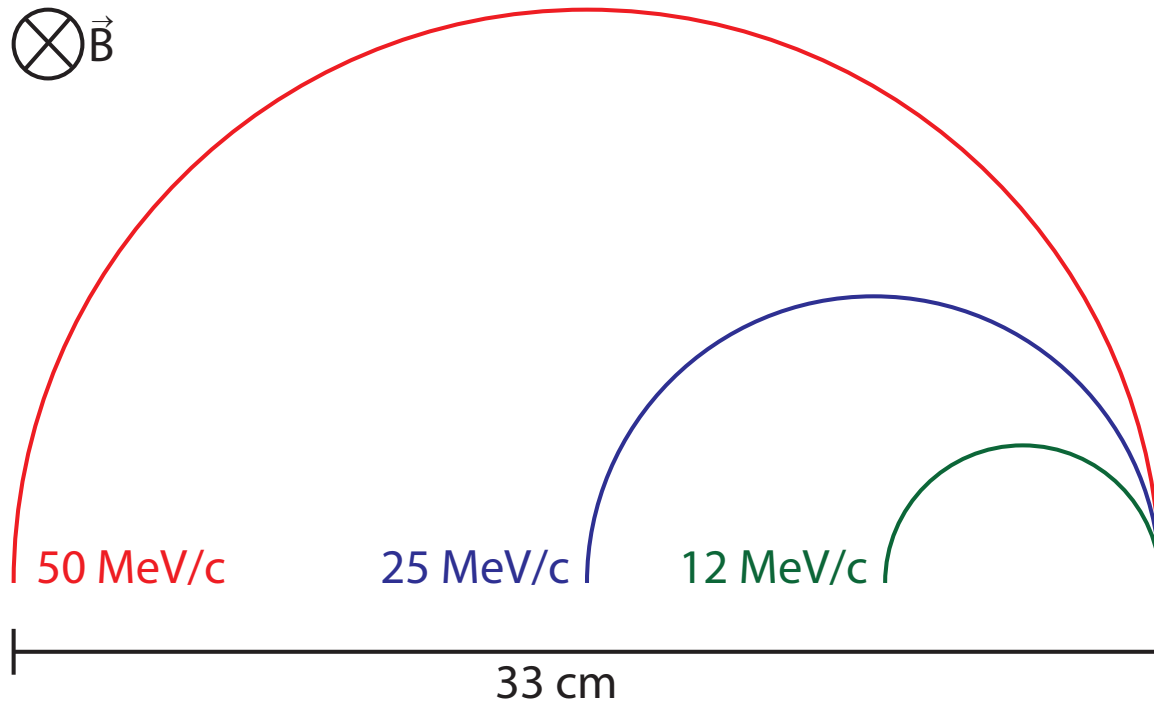

Precision vs. Acceptance

$\otimes \vec{B}$

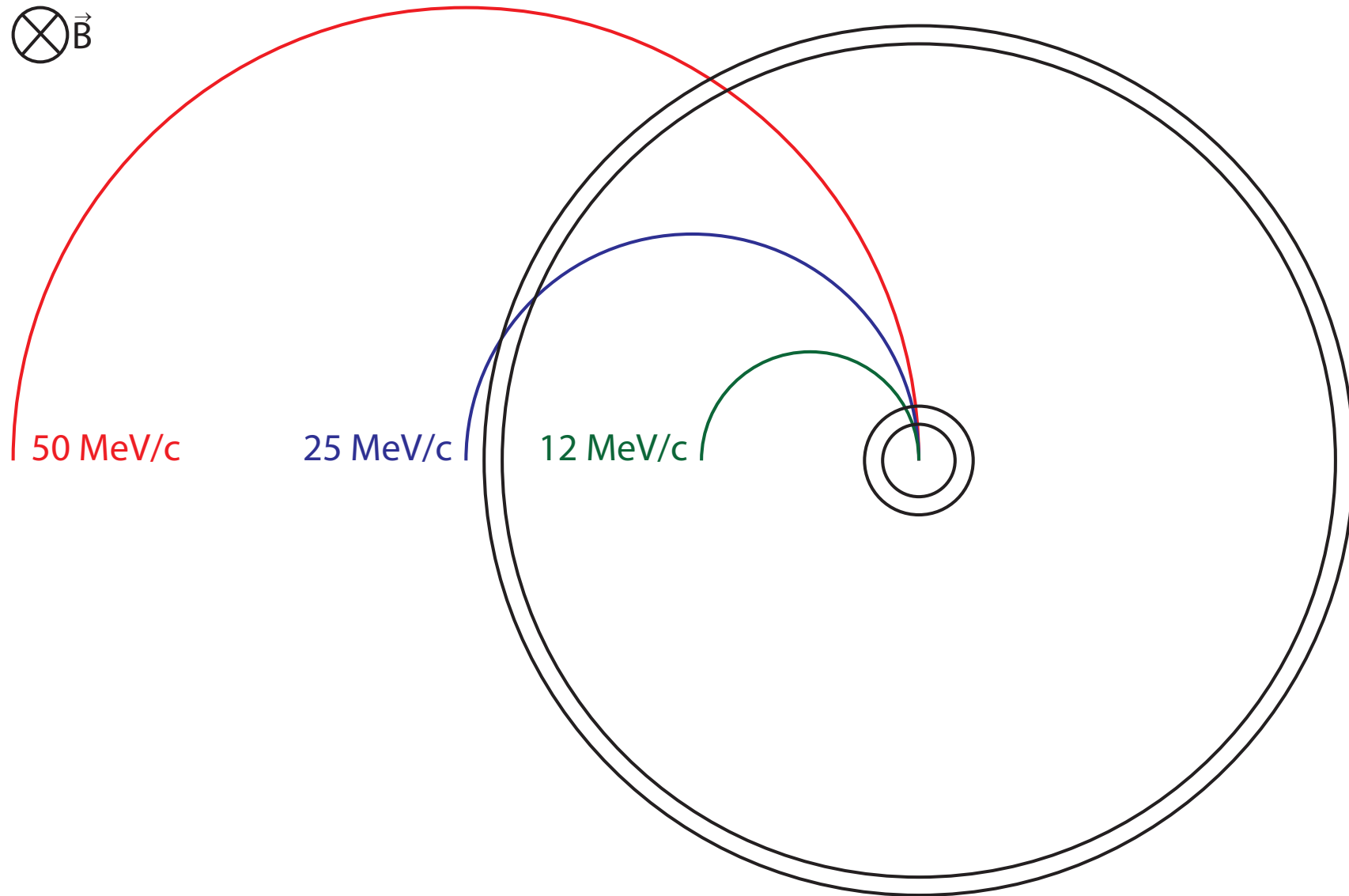

Precision vs. Acceptance

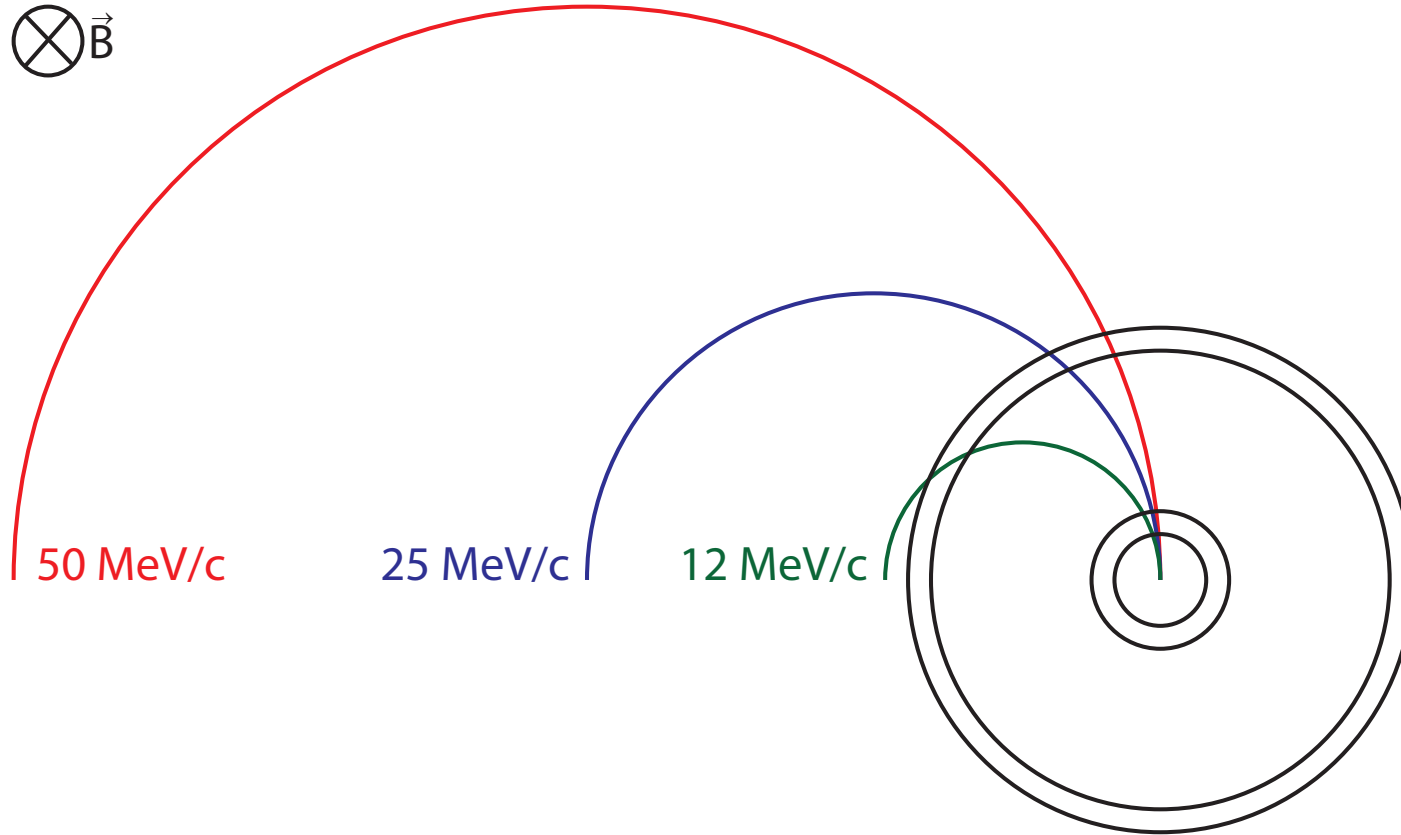

Precision vs. Acceptance

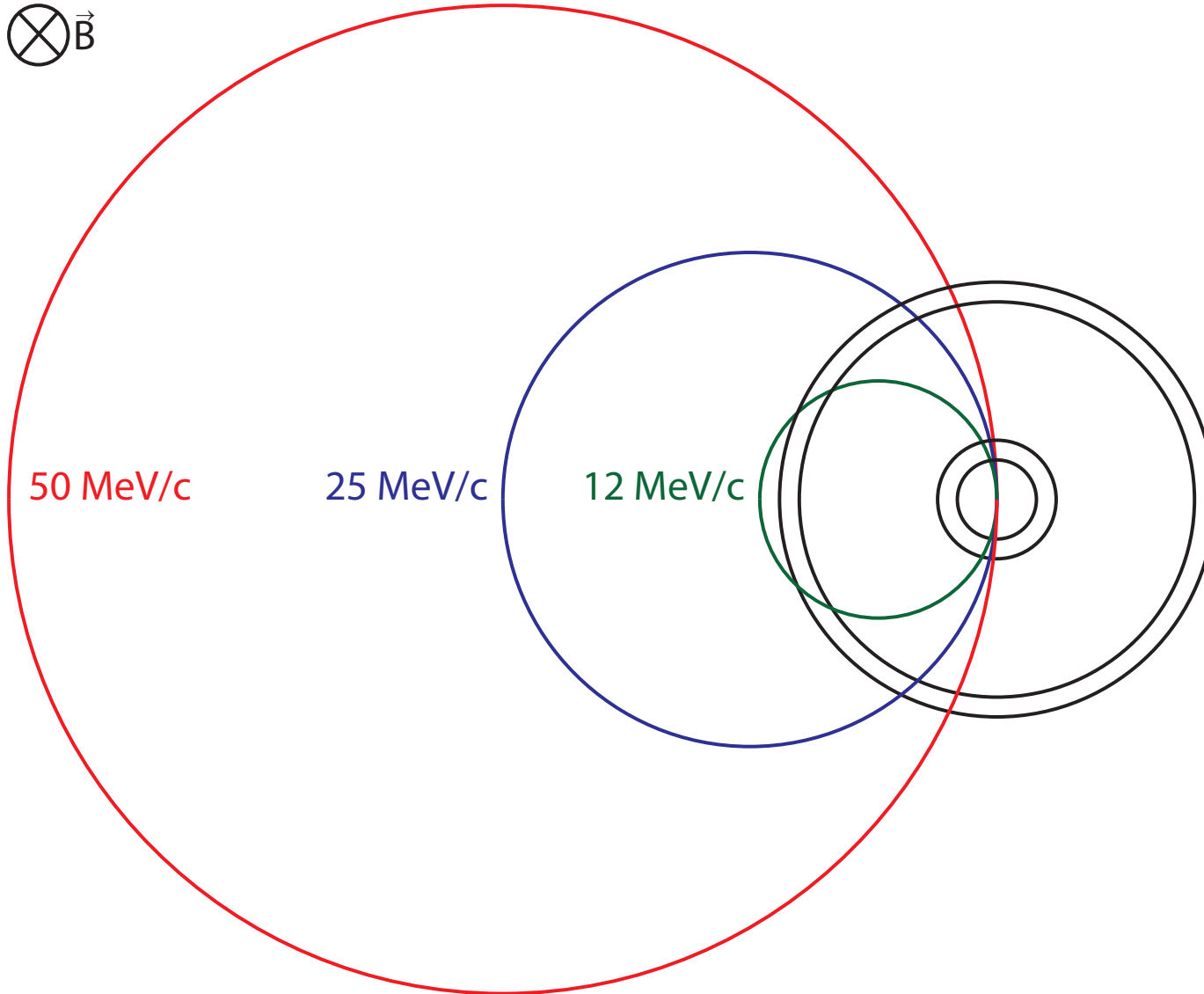

Precision vs. Acceptance

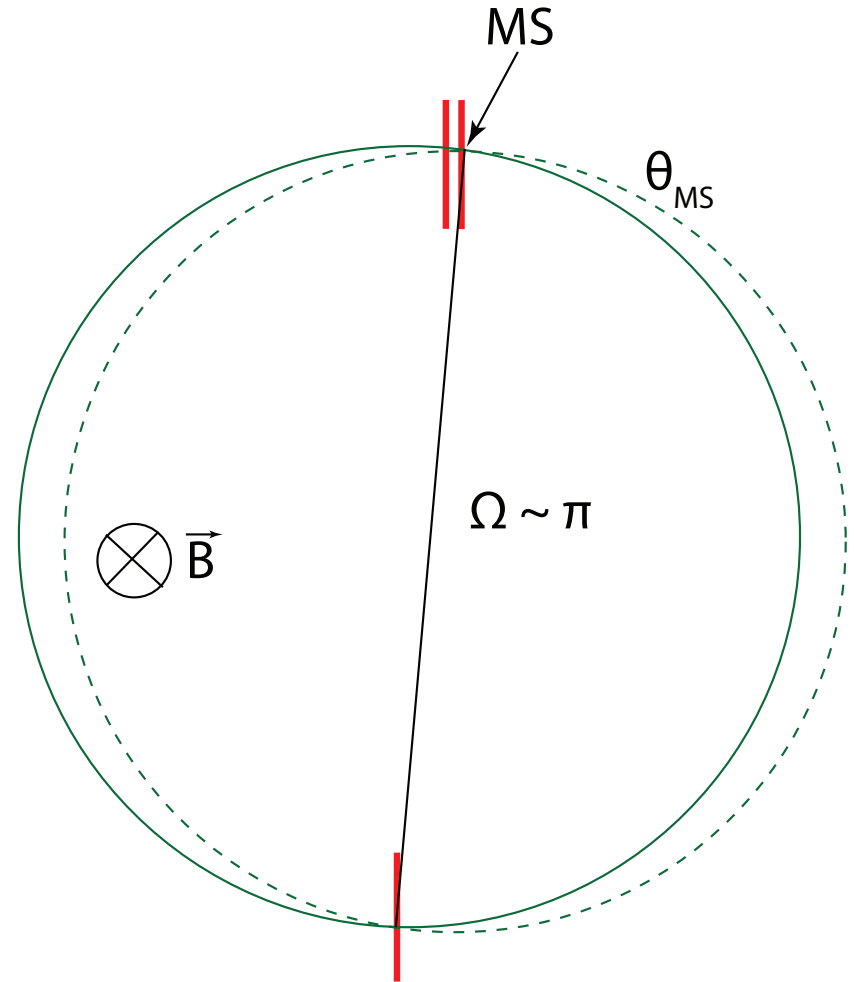
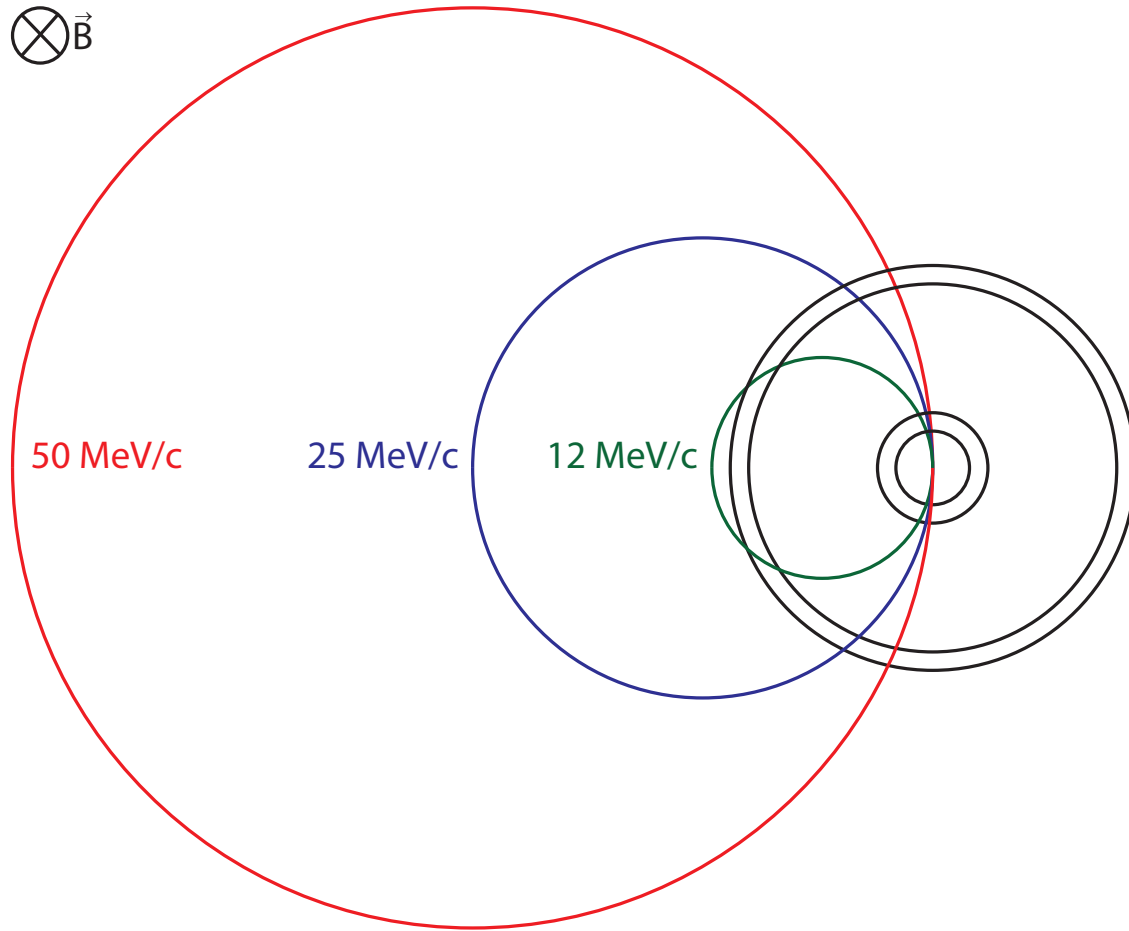



Detector Design

muon beam

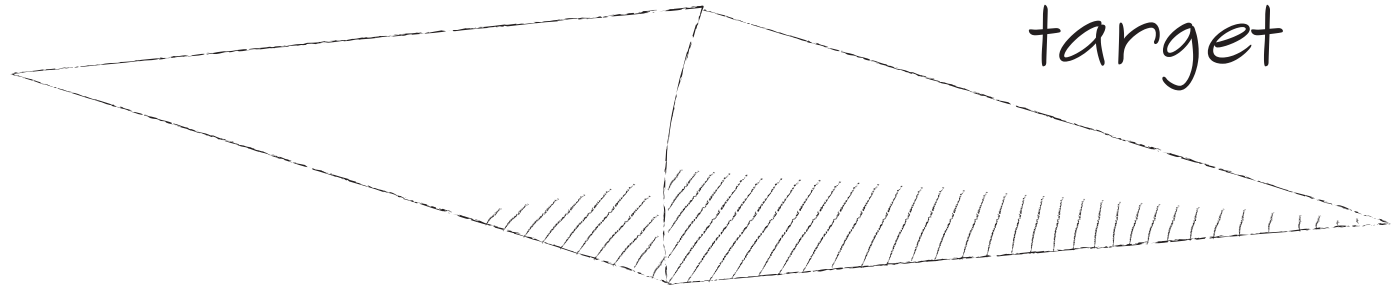
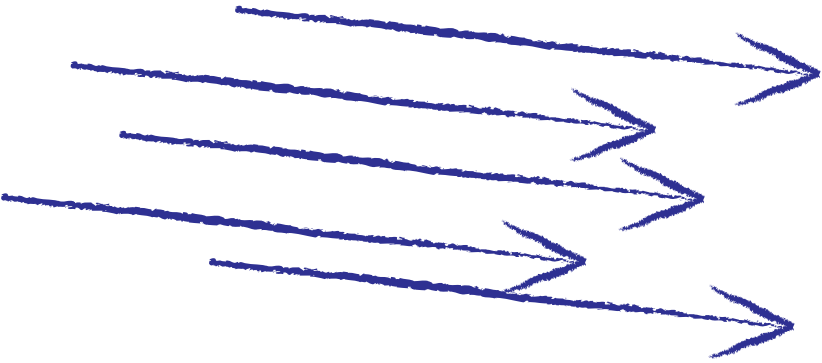



Detector Design

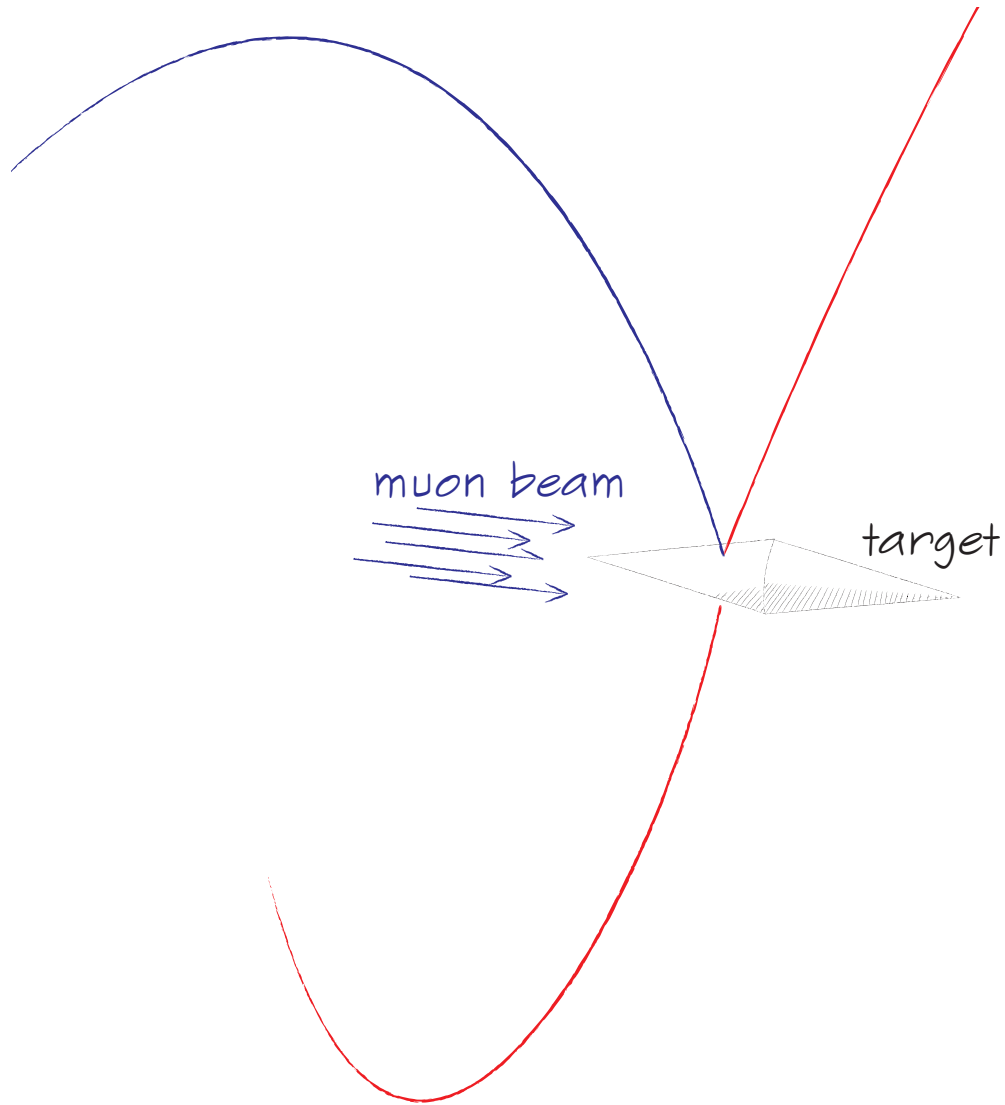



Detector Design

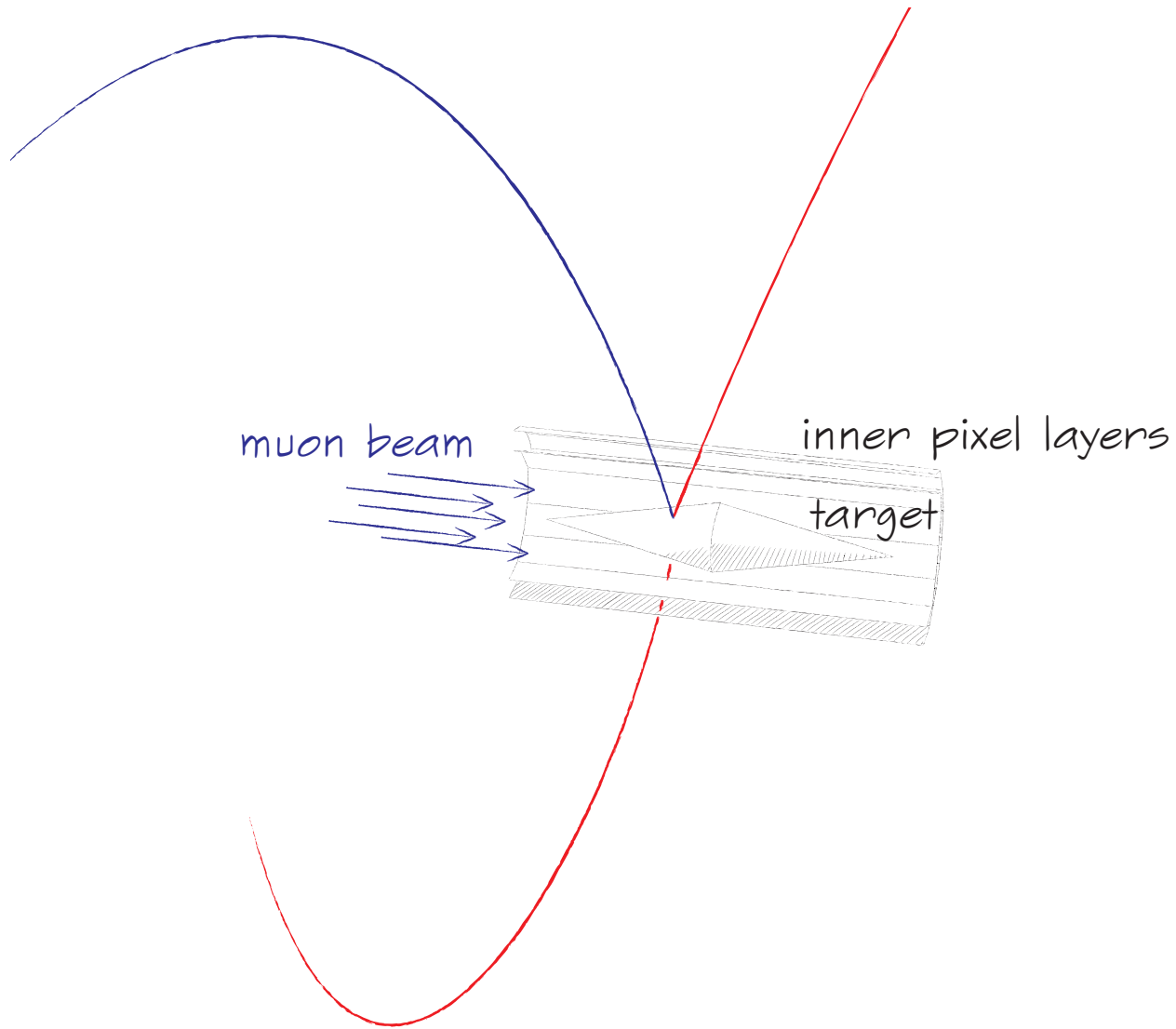



Detector Design

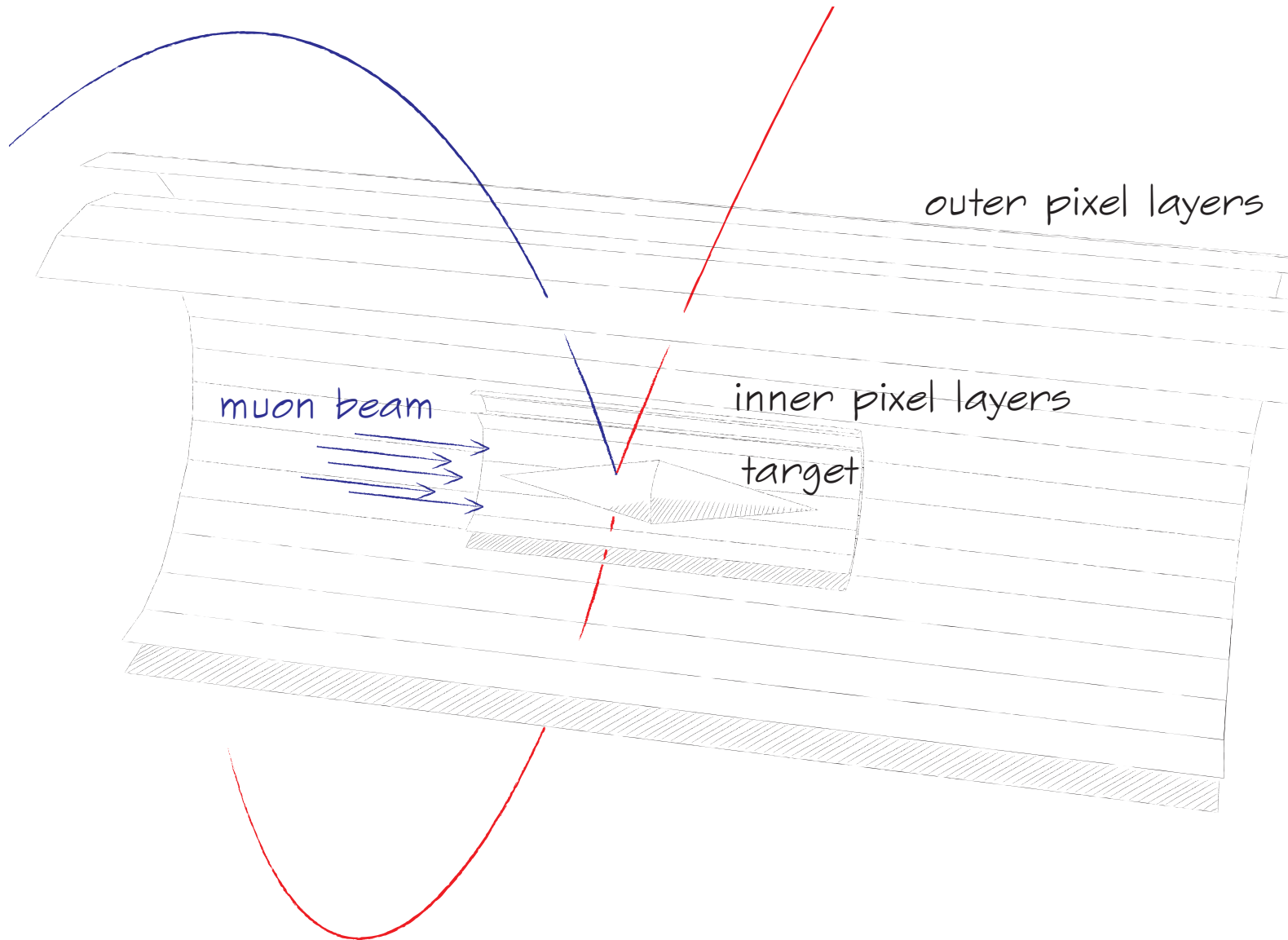



Detector Design

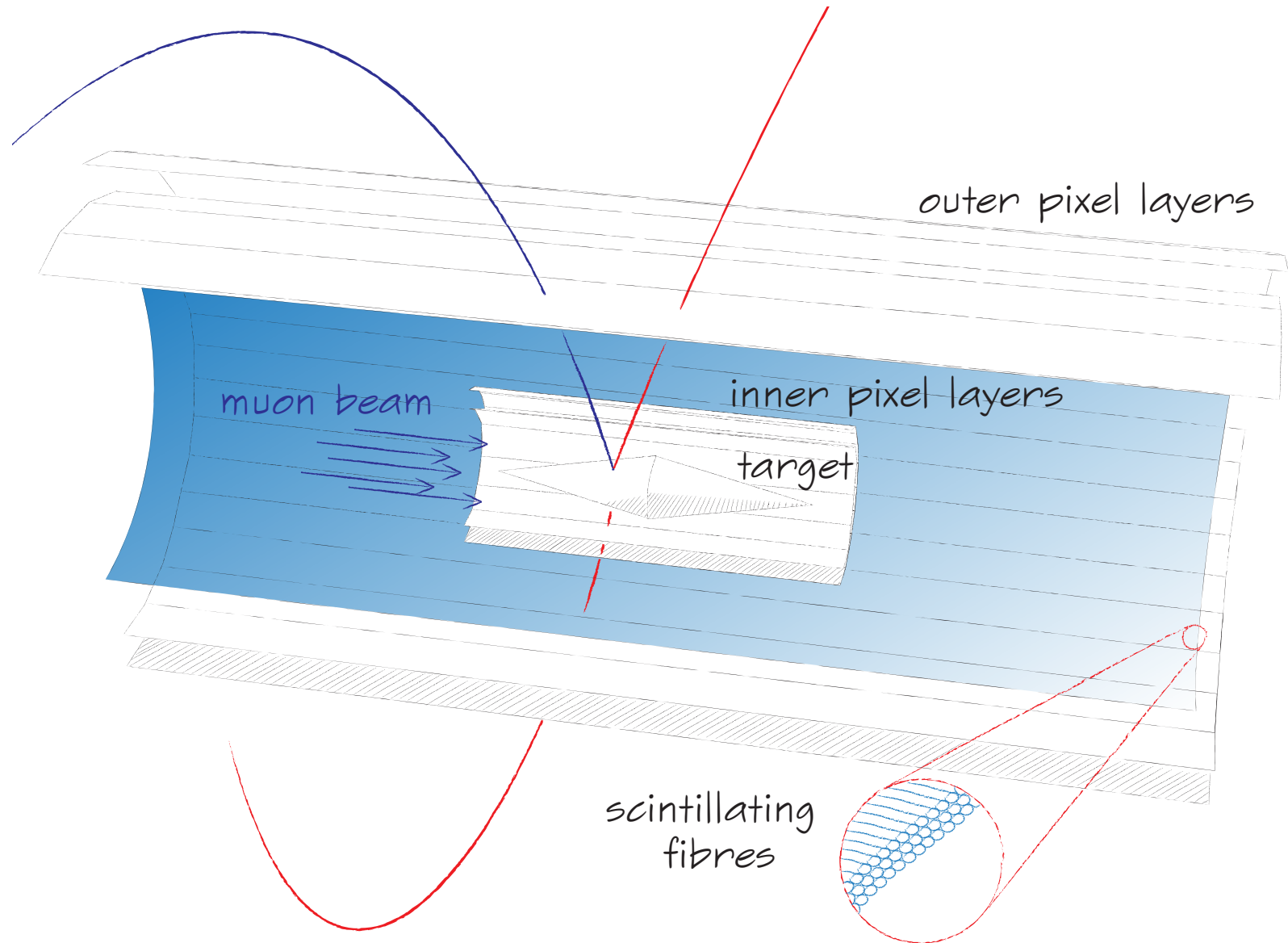



Detector Design

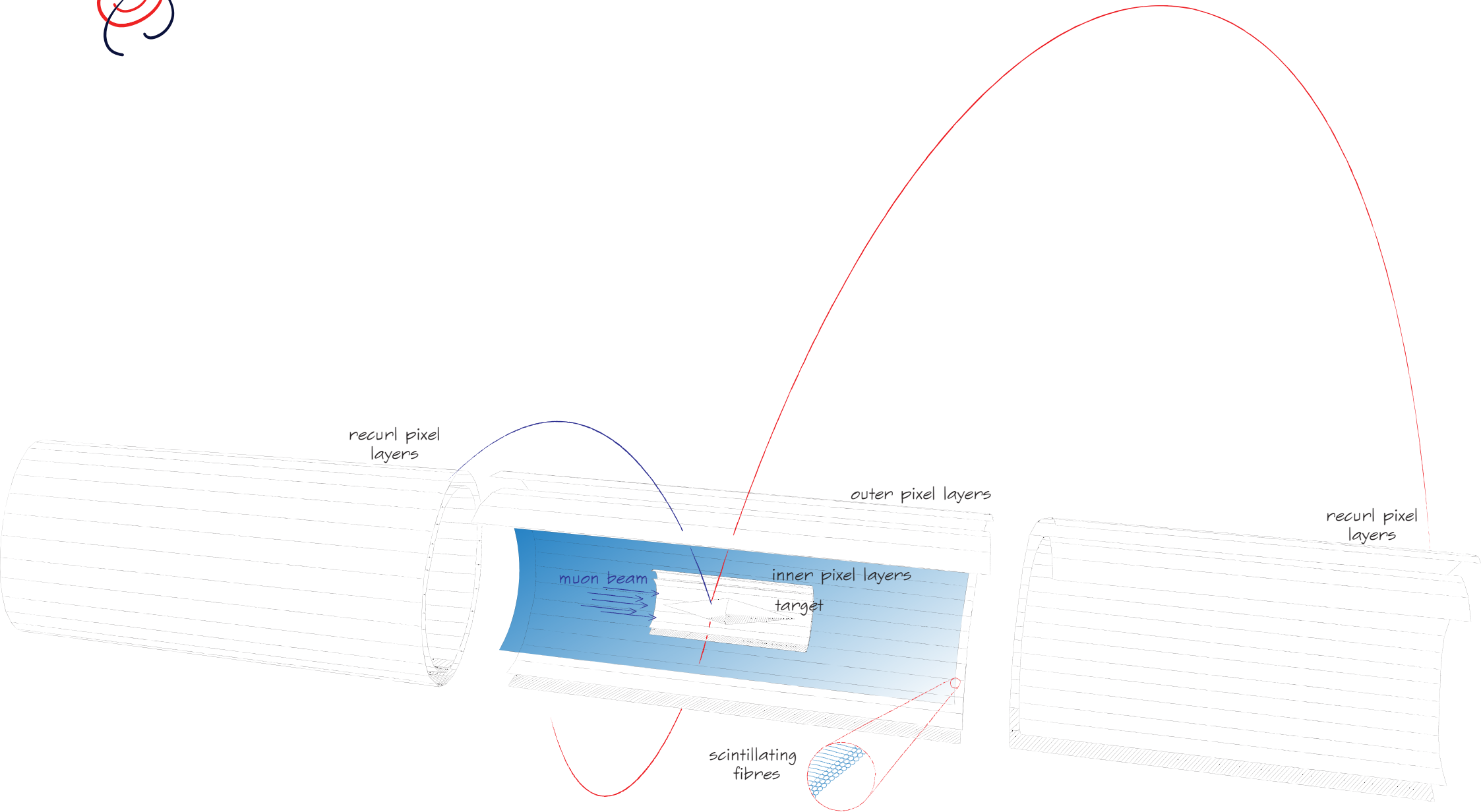



Detector Design

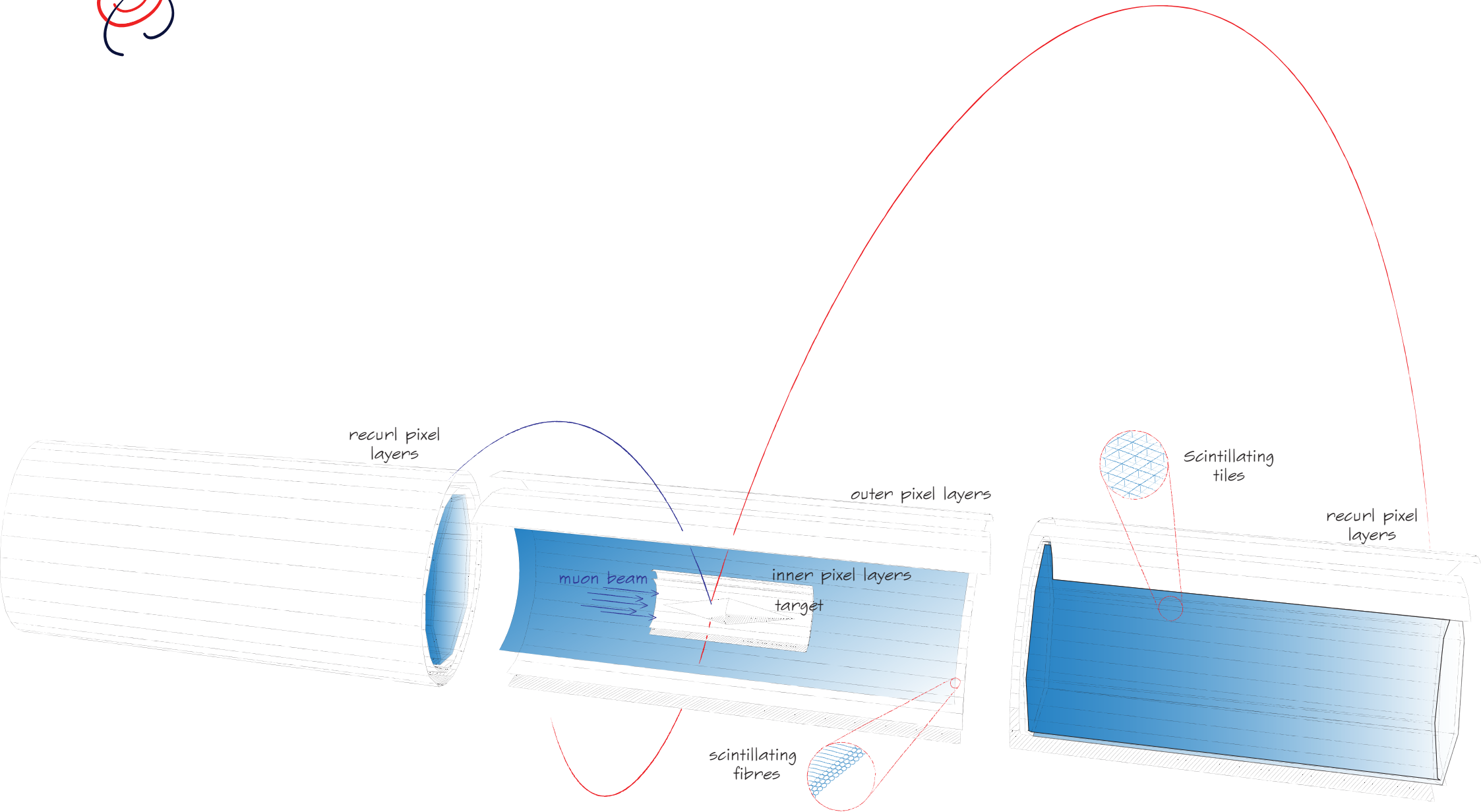



Detector Design

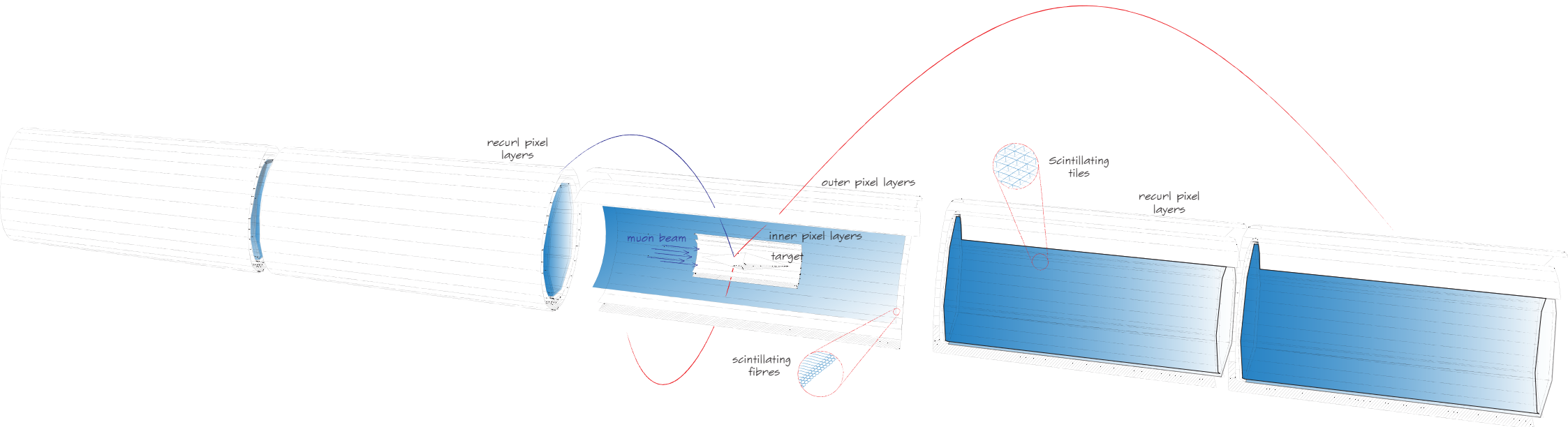



Timing measurements

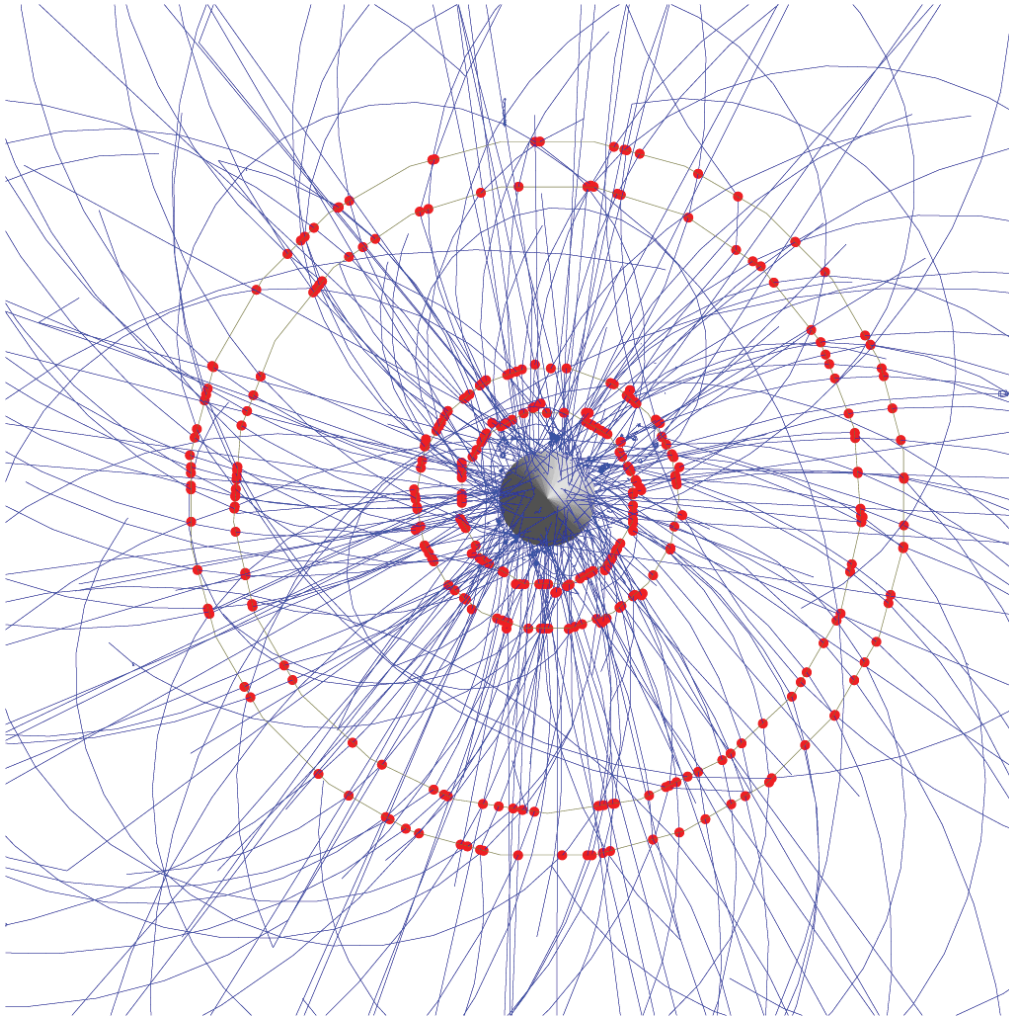

Pixels: $O(50 \text{ ns})$

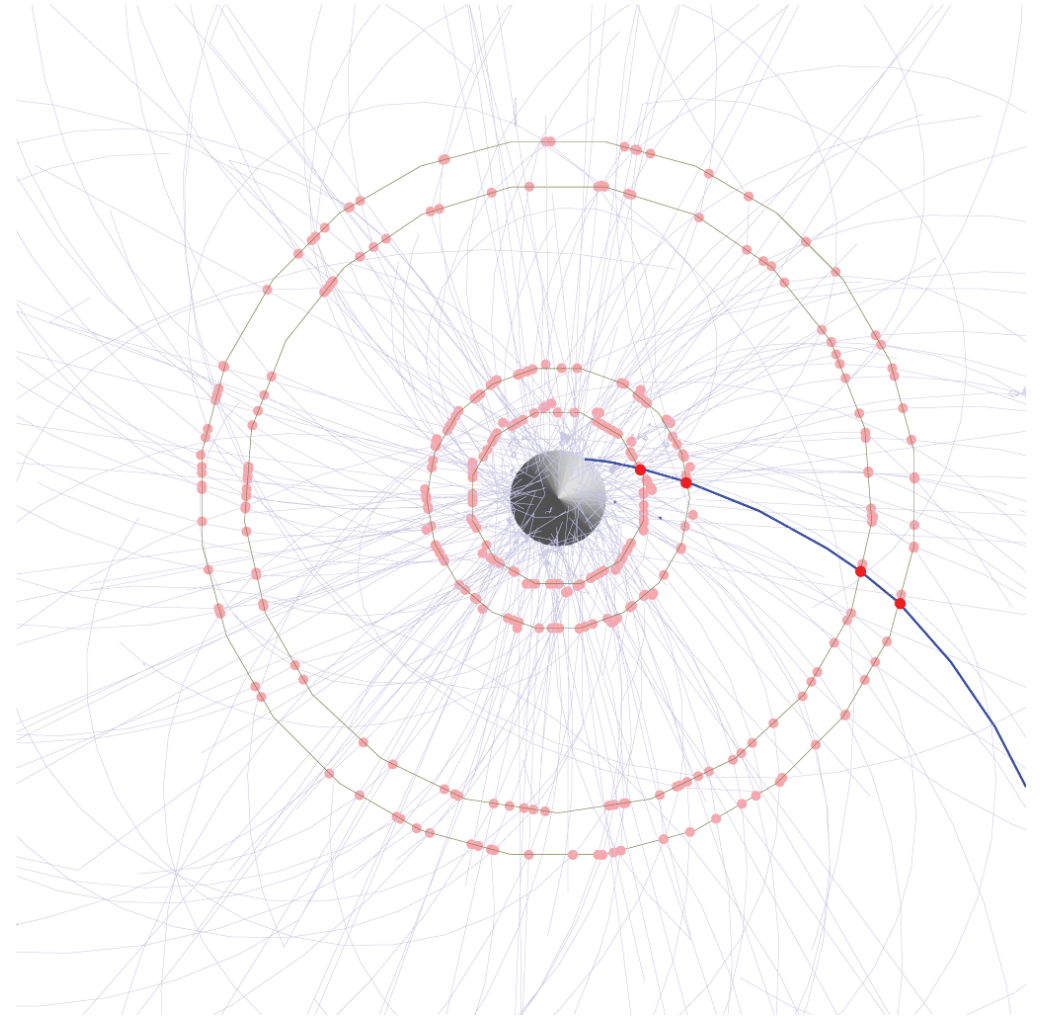

Scintillating fibres $O(1 \text{ ns})$;
Scintillating tiles $O(100 \text{ ps})$



Timing Detector: Scintillating Fibres

- 3-5 layers of 250 μm scintillating fibres
- Read-out by silicon photomultipliers (SiPMs) and custom ASIC (STiC)
- Timing resolution $\mathcal{O}(1 \text{ ns})$ (measured with sodium source)

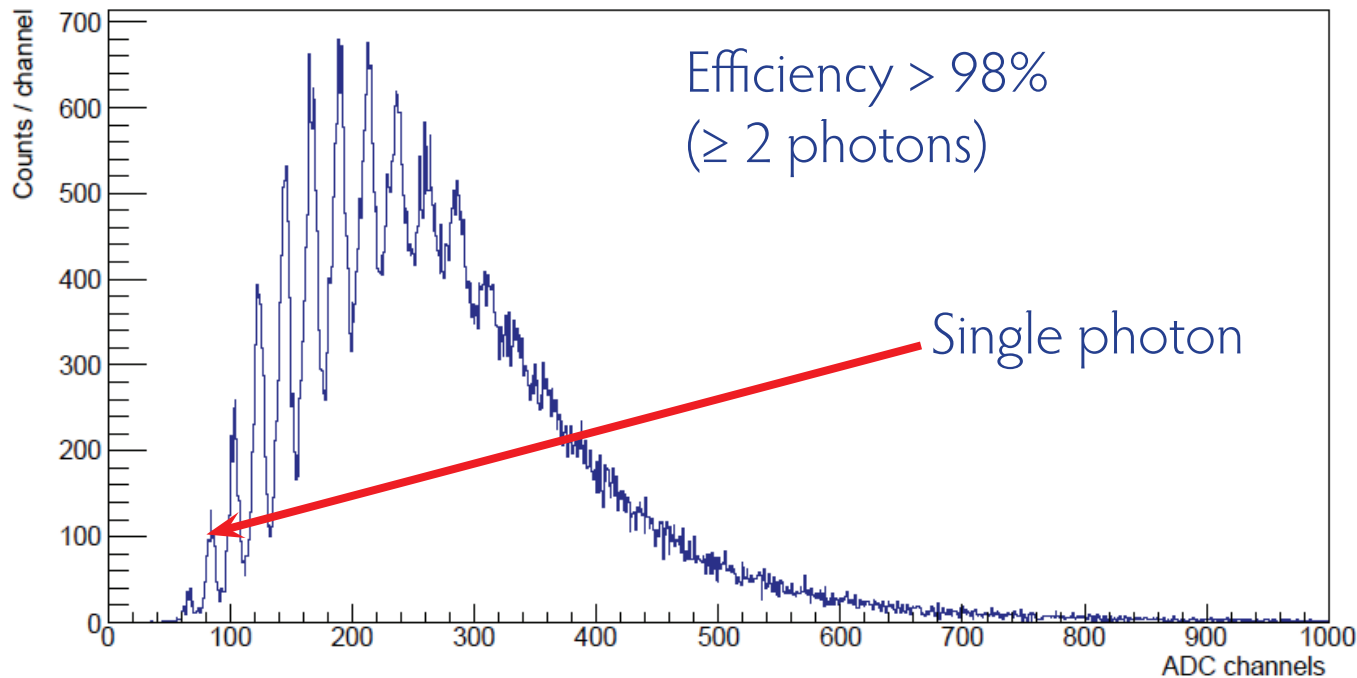
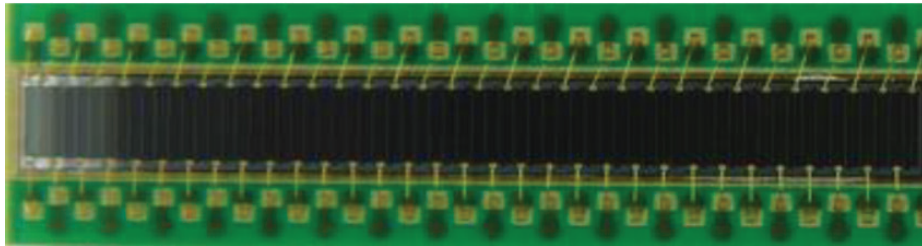



Timing Detector: Scintillating tiles

- $\sim 0.5 \text{ cm}^3$ scintillating tiles
- Read-out by silicon photomultipliers (SiPMs) and custom ASIC (STiC)

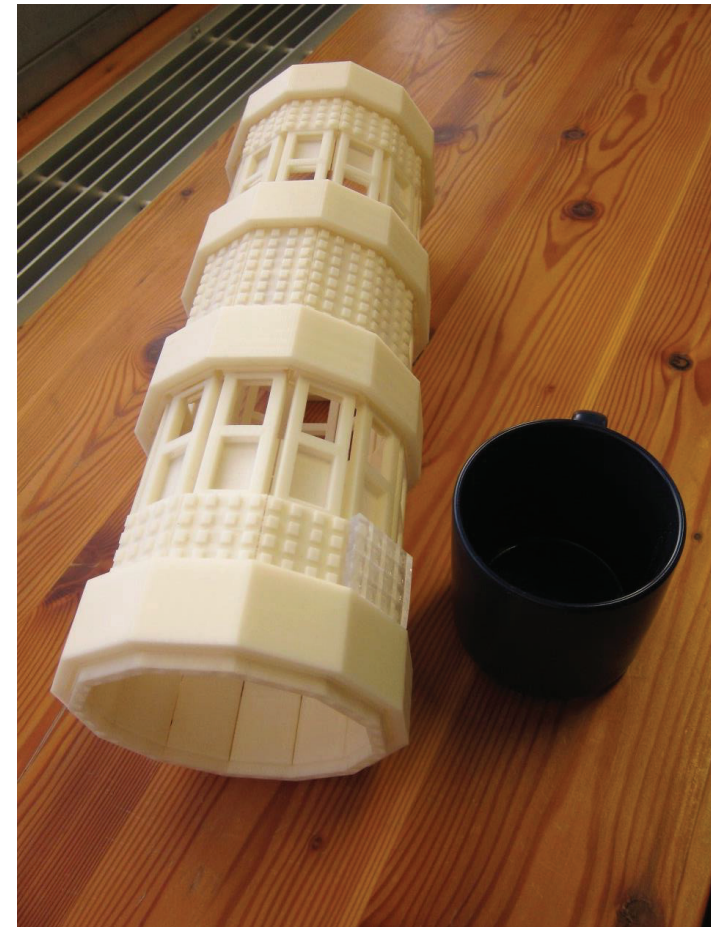
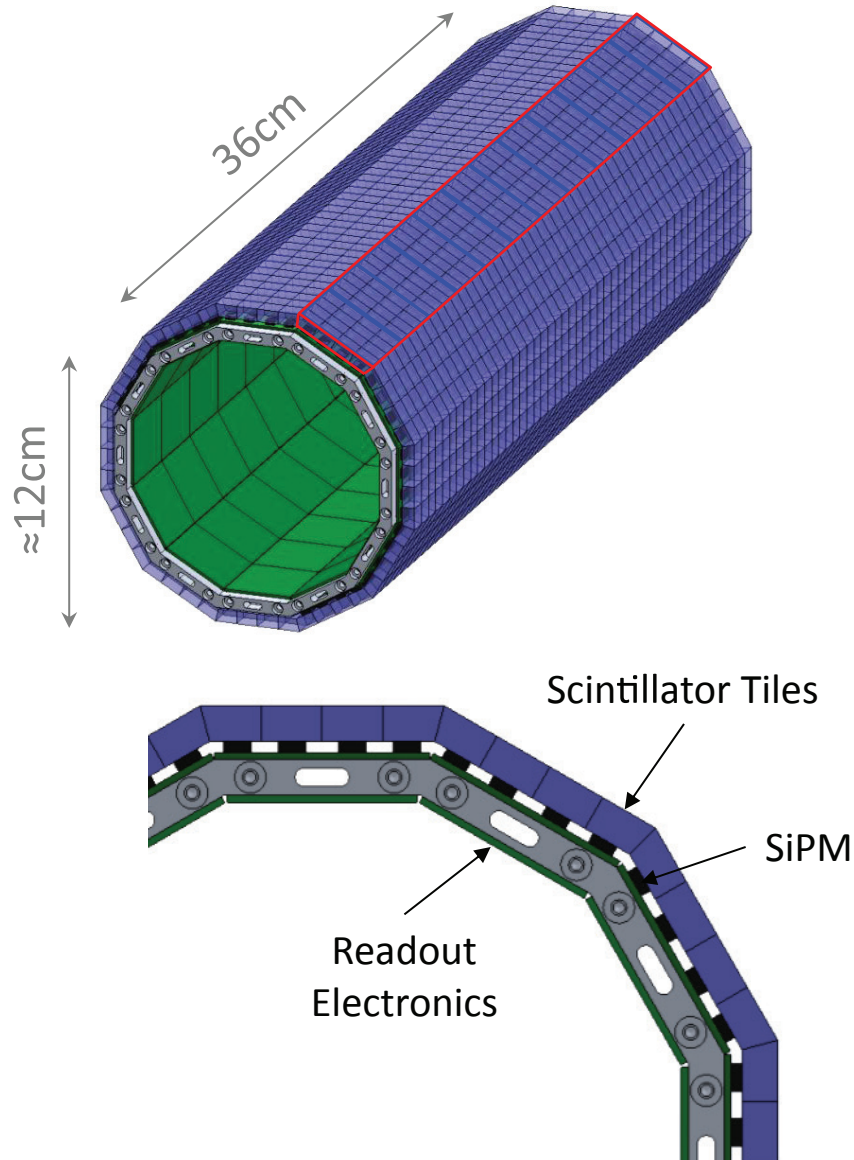



Timing Detector: Scintillating tiles

Front

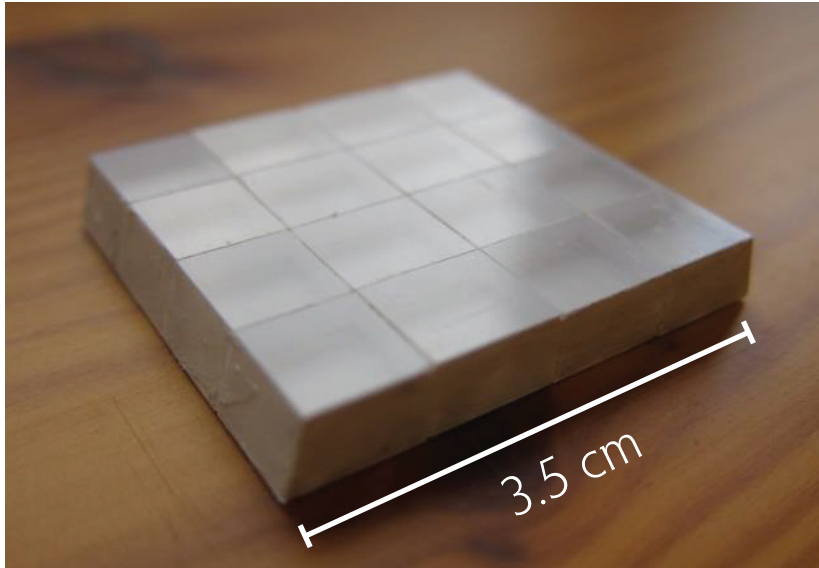

Back

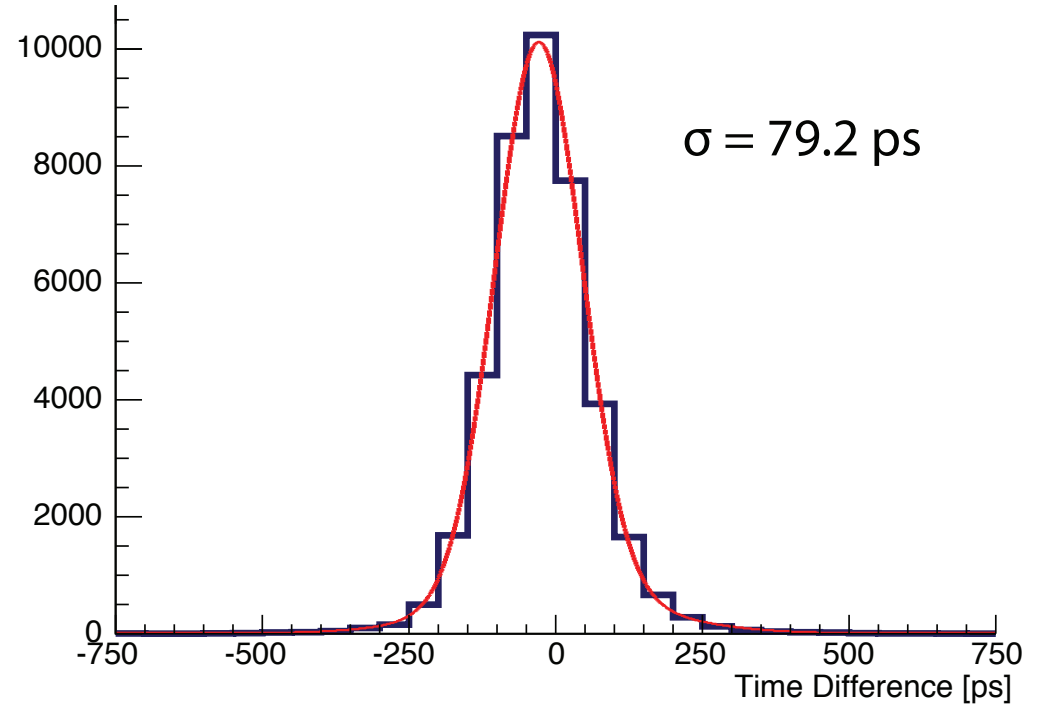

- Test beam with tiles, SiPMs and readout ASIC
- Timing resolution $\sim 80 \text{ ps}$



Data Acquisition

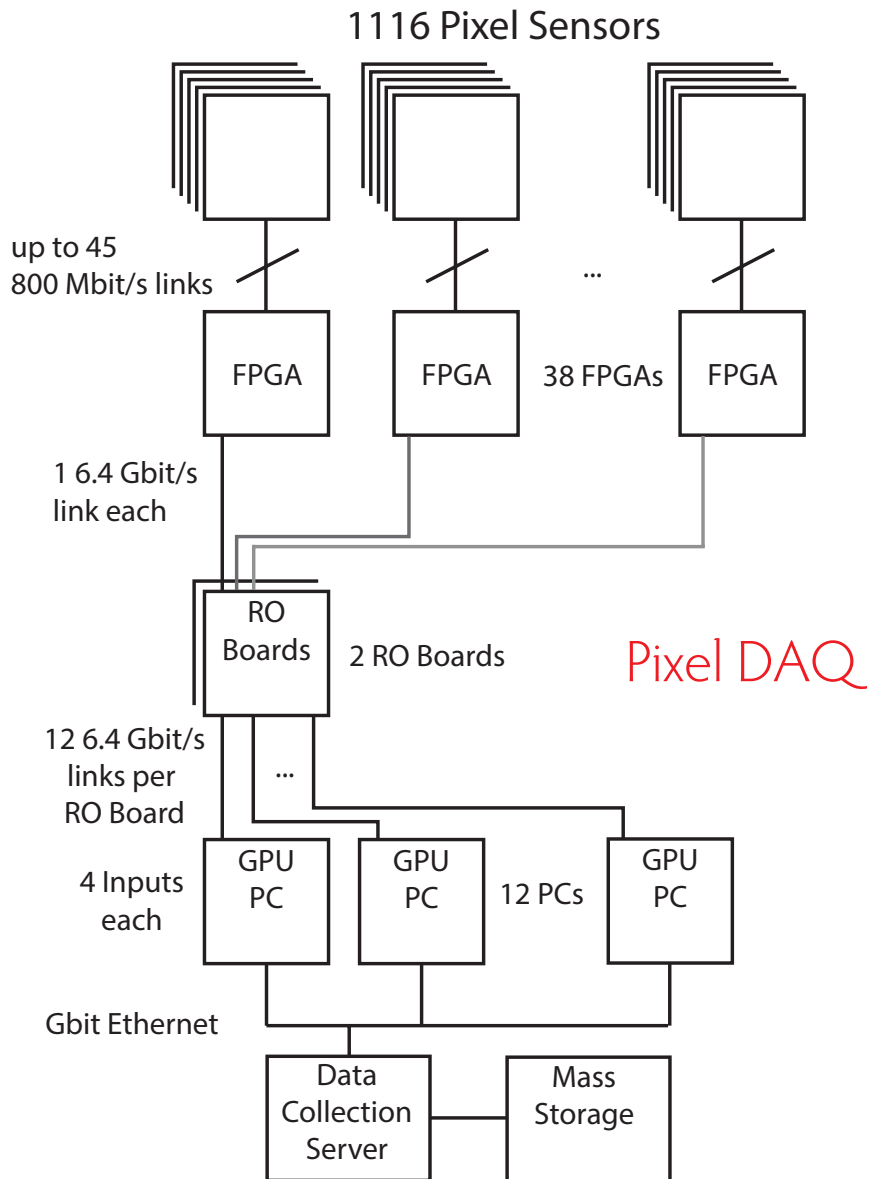

- 280 Million pixels (+ fibres and tiles)
- No trigger
- ~ 1 Tbit/s
- FPGA-based switching network
- O(50) PCs with GPUs

Online filter farm



Online software filter farm

- Continuous front-end readout (no trigger)
- ~ 1 Tbit/s
- PCs with FPGAs and Graphics Processing Units (GPUs)
- Online track and event reconstruction
- 10^9 3D track fits/s achieved
- Data reduction by factor ~ 1000
- Data to tape < 100 Mbyte/s



Simulated Performance

- 3D multiple scattering track fit
- Simulation results:
 - 280 keV single track momentum
 - 520 keV total mass resolution

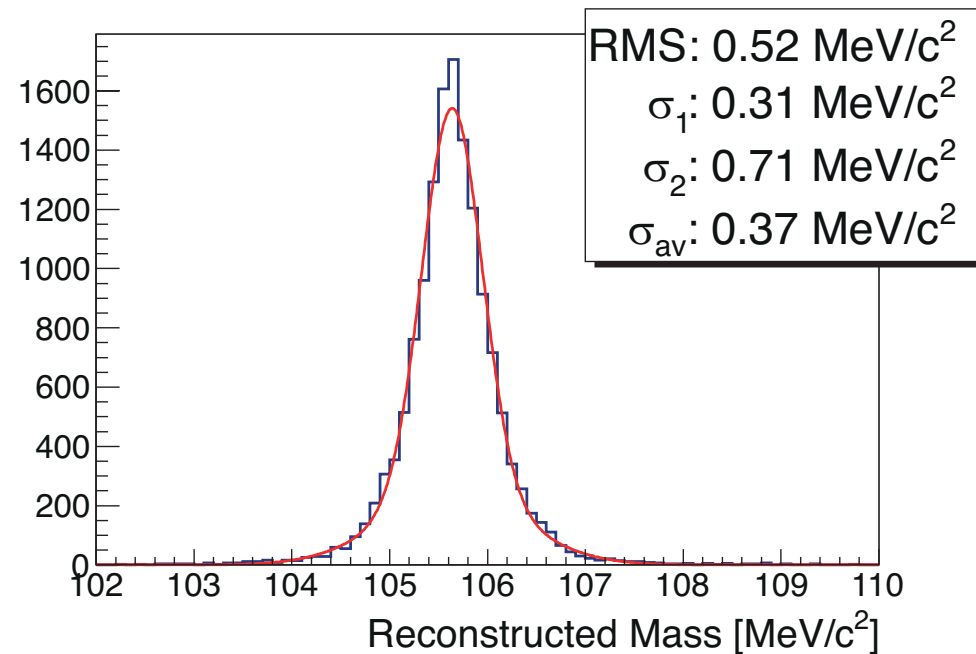
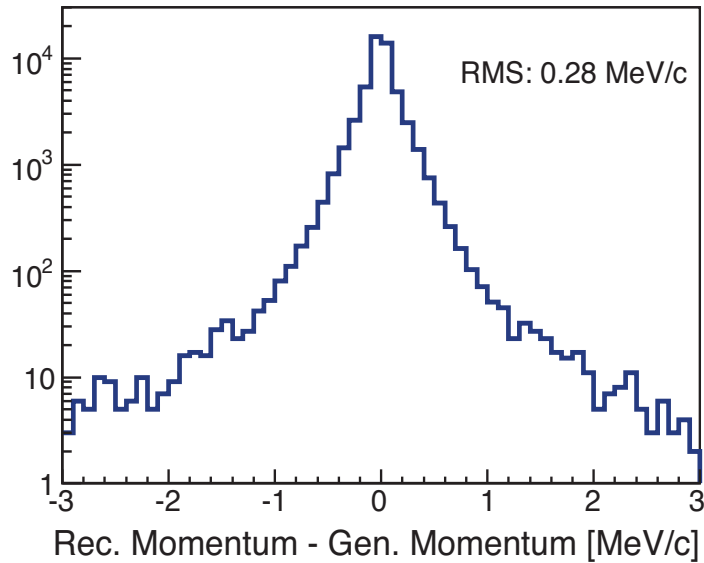



Simulated Performance

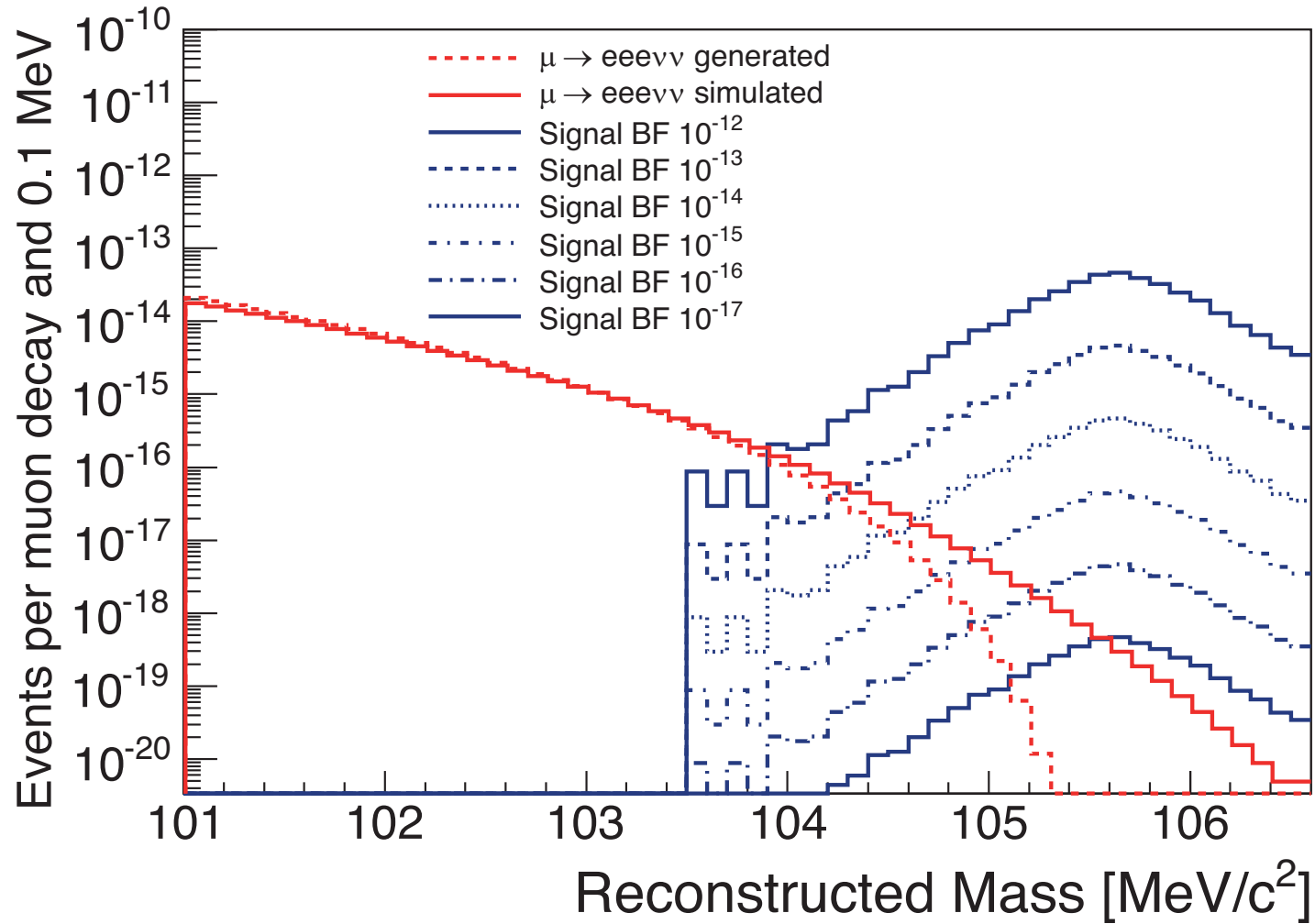



Sensitivity

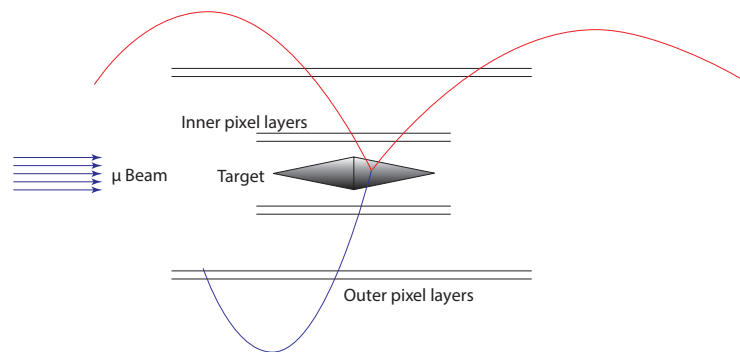
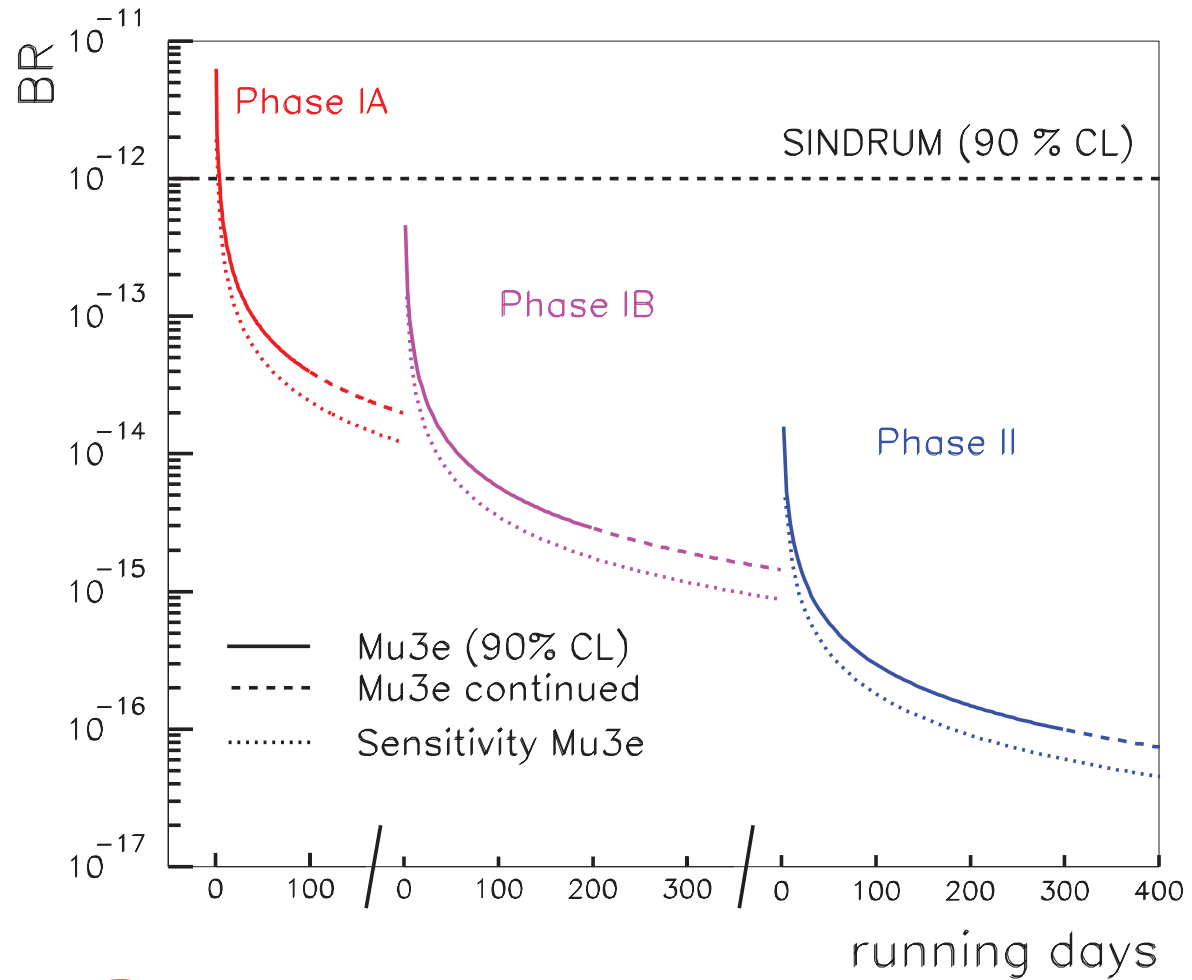

Phase IA: Starting 2016
 $2 \cdot 10^7 \mu/s$



Sensitivity

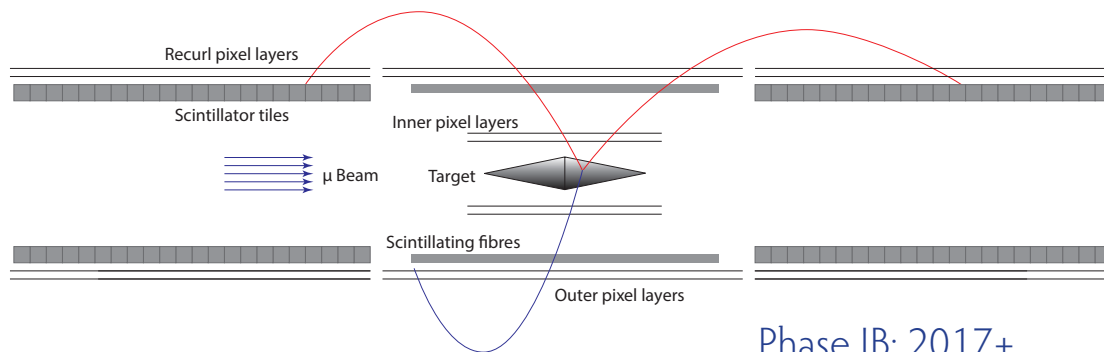
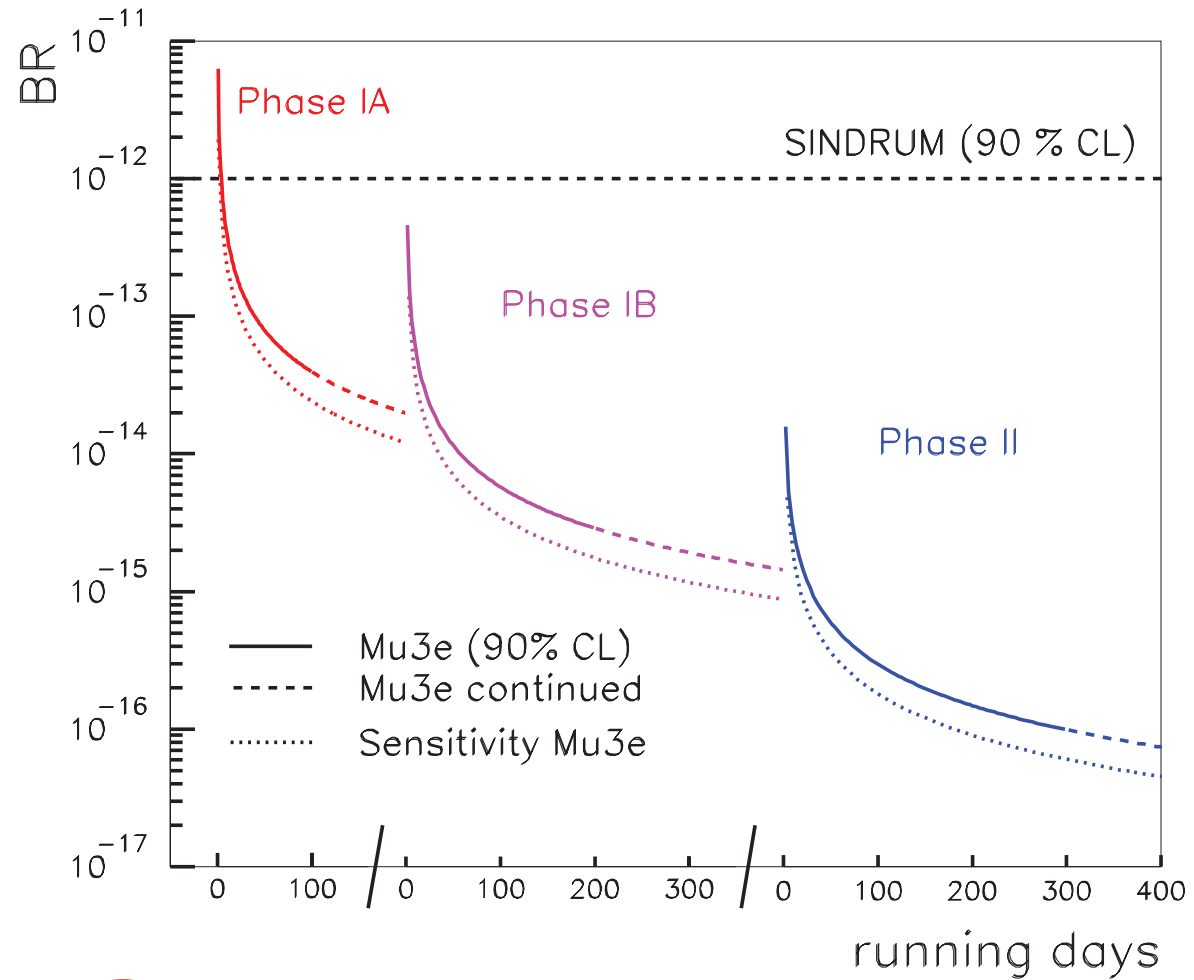

Phase IB: 2017+
 $1 \cdot 10^8 \mu/s$



Sensitivity

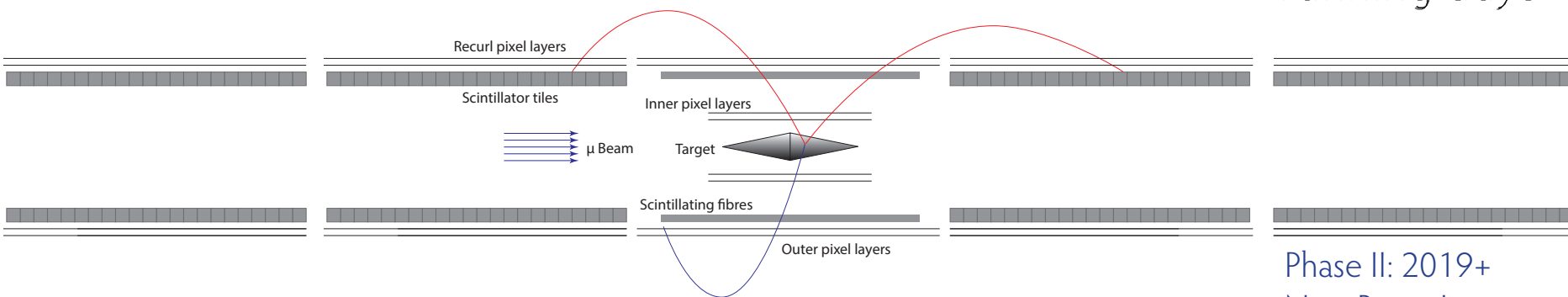
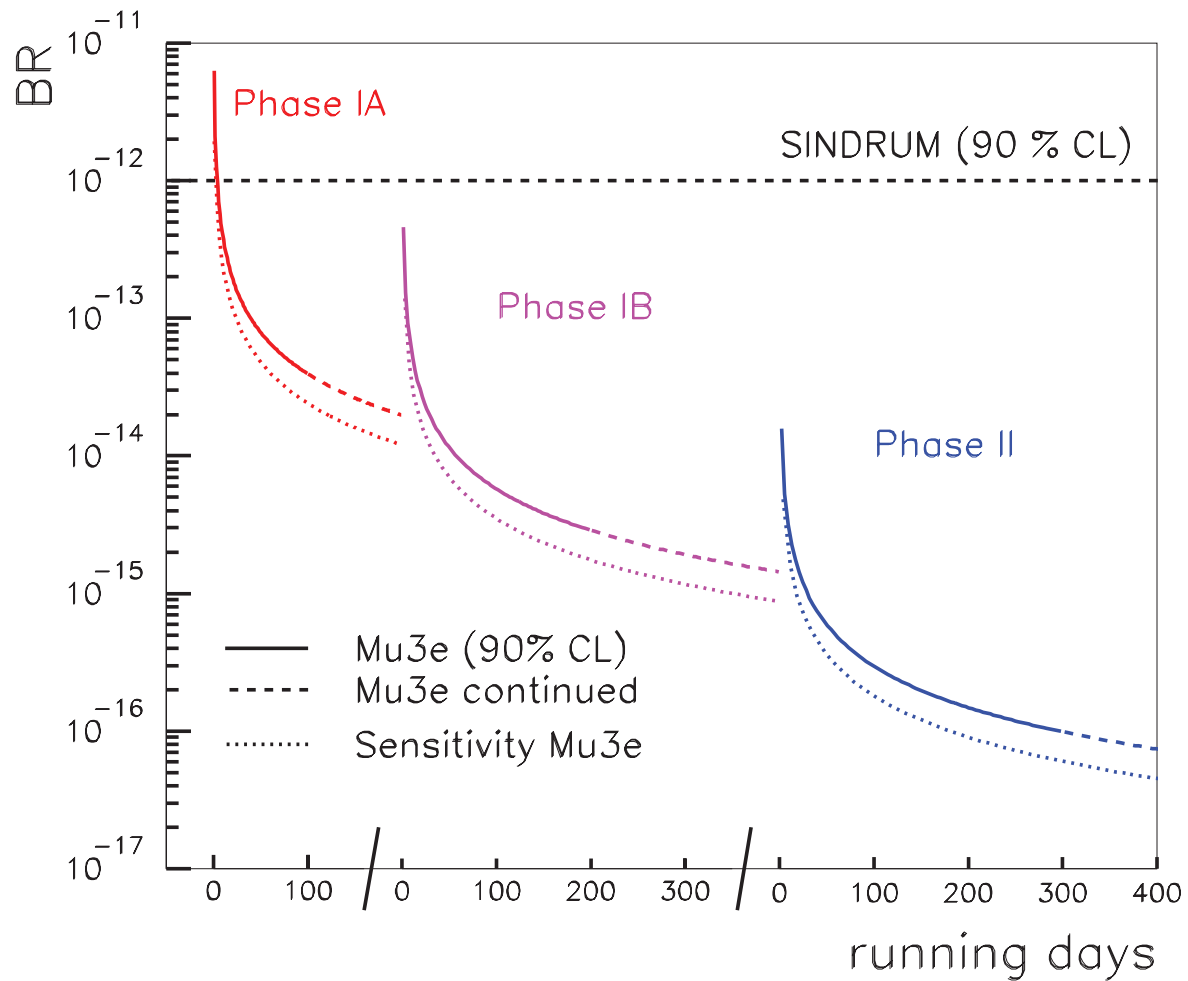

Phase II: 2019+
 New Beam Line
 $2 \cdot 10^9 \mu/s$

$\mu 3e$ Conclusion

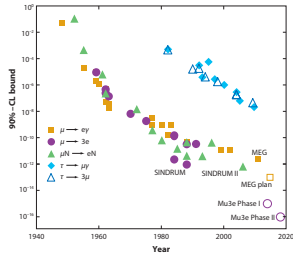

- Mu3e aims for $\mu \rightarrow eee$ at the 10^{-16} level

- First large scale use of HV-MAPS

- Build detector layers thinner than a hair

- Timing at the 100 ps level

- Reconstruct 2 billion tracks/s in 1 Tbit/s on ~50 GPUs

- Start data taking in 2016

- 2 billion muons/s not before 2019

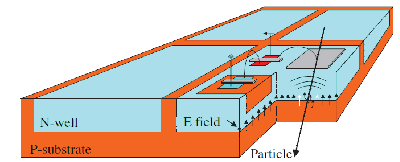



Backup Material





Radiation Hardness

- Requirements not as strict as at LHC

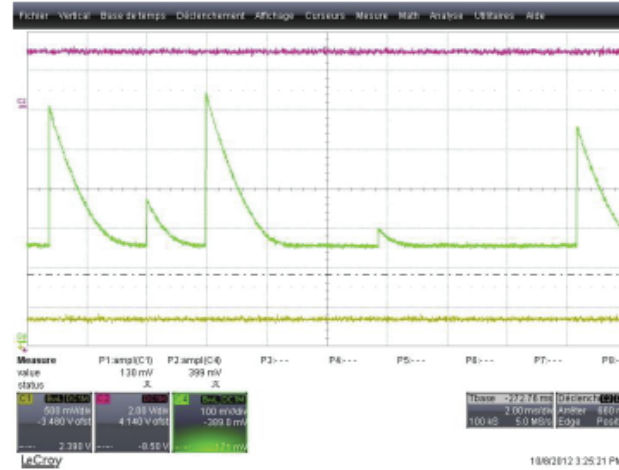
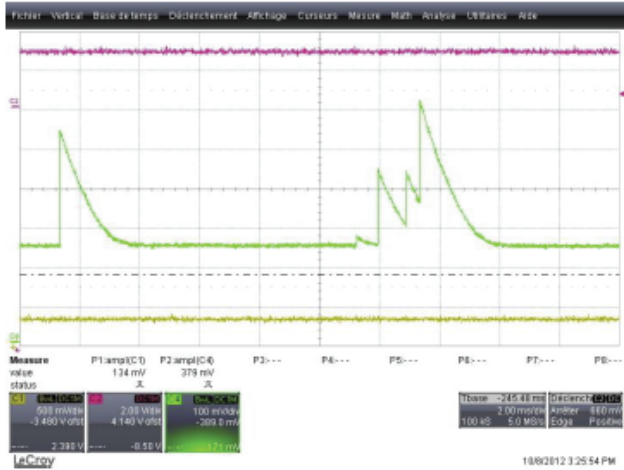

The chip works, particles are measured when the chip is in the beam: Output of the amplifier

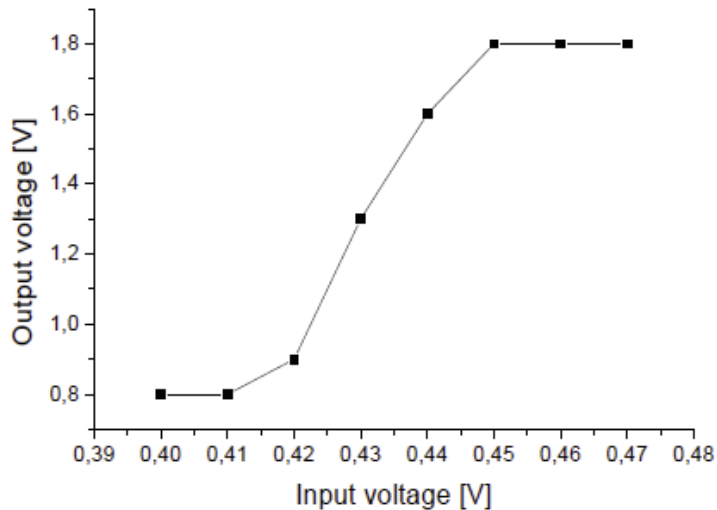

Comparator characteristics.

- Irradiation at PS
- After 380 MRad ($8 \times 10^{15} n_{eq}/cm^2$)
- Chip still working

(Courtesy Ivan Perić, RESMDD 2012)



MUPIX electronics

