

Internal Report
DESY M 98-11
October 1998



**Reports at the
XIX International Linear Accelerator Conference
LINAC 98**

**August 23 –28, 1998
Chicago, USA**

Deutsches Elektronen-Synchrotron DESY, Hamburg, Germany

DESY behält sich alle Rechte für den Fall der Schutzrechtserteilung und für die wirtschaftliche Verwertung der in diesem Bericht enthaltenen Informationen vor.

DESY reserves all rights for commercial use of information included in this report, especially in case of filing application for or grant of patents.

**"Die Verantwortung für den Inhalt dieses
Internen Berichtes liegt ausschließlich beim Verfasser"**

CONTENTS

Invited Talks

- A* J. Peters Review of Negative Hydrogen Ion Sources
High Brightness/High Current
- B* J. Rossbach, for the
TESLA FEL Collaboration The TESLA Free Electron Laser – Concept and Status
- C* D. Trines, for the
TESLA Collaboration Status of the TESLA Design
- D* H. Weise, for the
TESLA Collaboration High Gradient Superconducting RF Structures

Talks

- E* S. Choroba, J. Hameister,
S. Jarylkapov Performance of an S-Band Klystron at an
Output Power of 200 MW
- F* S. Choroba, J. Hameister,
M. Kuhn Performance of the Klystron Modulators at the
S-Band Test Facility at DESY
- G* M. Dohlus, H. Hartwig,
N. Holtkamp, A. Jöstingmeier Design of a HOM Broadband Absorber for TESLA
- H* M. Dohlus, N. Holtkamp,
A. Jöstingmeier Systematic Design of an S-Band Pillbox-Type
RF Window
- I* M. Dohlus, N. Holtkamp,
A. Jöstingmeier Application of the Mode Matching Technique to the
Analysis of Waveguide Arrays
- J* A. Gamp, S. Goloborodko,
M. Hüning, A. Kholodnyi,
M. Liepe, T. Plawski,
K. Rehlich, T. Schilcher,
S.N. Simrock, Y. Tchernouosko Experience with the Control of the Vector Sum at the
TESLA Test Facility
- K* A. Gamp, M. Liepe, T. Plawski,
K. Rehlich, S.N. Simrock Design of the RF Phase Reference System and
Timing Control for the TESLA Linear Collider
- L* M. Hüning, S.N. Simrock System Identification for the Digital RF Control System
at the TESLA Test Facility
- M* M. Hüning, T. Schilcher,
S.N. Simrock Requirements for the RF Control of the Vector Sum for
Superconducting Proton Linacs
- N* H. Imsieke, A. Kholodnyi,
S.N. Simrock Time Delay Compensation for the Digital RF Control
at the TESLA Test Facility

O C.-M. Kleffner, N. Holtkamp,
M. Nagl, H. Poggensee,
J. Peters, A. Schempp

Operation of the Upgraded H⁻ - Injection System of the
Linac III at DESY

P M. Liepe, S.N. Simrock

Adaptive Feed Forward for the
Digital RF Control System at the TESLA Test Facility

Q W.-D. Möller, for the
TESLA Collaboration

The Performance of the 1.3 GHz Superconducting
RF Cavities in the First Module of the
TESLA Test Facility Linac

PERFORMANCE OF THE KLYSTRON MODULATORS AT THE S-BAND TEST FACILITY AT DESY

S. Choroba, J. Hameister, M. Kuhn

Deutsches Elektronen-Synchrotron, DESY, 22603 Hamburg, Germany

Abstract

The klystrons at the S-band test facility at DESY require high voltage pulses of 550kV at a flat top pulse duration of 3 μ s, at a current of 700A and a repetition frequency of 50Hz. Two HV pulse modulators with a nominal power of 375MW were built. The design and results of the commissioning of the first system were described in [1]. The second system came into operation and was operated at an output power up to 475MW (610kV, 780A). In addition it was modified to investigate capacitor charging power supplies, which might be used in a linear collider tunnel. This type of power supply promises a better efficiency than the conventional resonant charging method and also saves space in the linear collider tunnel. This paper describes the operation experience with the HV modulators at the test facility especially with the second system. It reports the modifications, which were required to operate the modulator with the new type of HV power supply and presents results of the operation.

1 INTRODUCTION

The S-band test facility at DESY is a 400MeV electron linac, which serves for the development and evaluation of components which might be used for an S-band linear collider. Two pulse klystrons operating at 2.998GHz with a nominal output power of 150MW are installed at the test facility. The pulse duration is 3 μ s and the repetition rate 50Hz. In order to generate the microwave power of 150MW a klystron cathode voltage up to 550kV and a current up to 700A are required. The high voltage pulses of 3 μ s flat top pulse duration are produced by line type modulators. Although the resonance charging method, used in both modulators, is a well established and reliable technique to charge the capacitors of pulse forming networks, a new type of capacitor charging power supply, which is now available from different manufacturers, was installed at the second modulator. It can be used alternately with the existing resonance charging system. Constant current capacitor charging power supplies have a high efficiency and a compact size. Both are properties, which are especially desirable for modulators, which need to be installed in a linear collider tunnel, but of course are also of interest for other linear accelerators. The first modulator is in operation since three years and the second since one year. In the following we present a short

overview of the modulator system and report on our operation experience so far. After that we describe the modifications required to install the new charging power supply and present results of the measurements performed on the system.

2 LINE TYPE MODULATOR LAYOUT

Table 1 shows the parameters of the modulator and figure 1 shows the basic circuit diagram.

Table 1: Modulator parameters

Pulse Voltage	550 kV
Pulse Current	700 A
Flat Top Pulse Duration	3 μ s
Repetition Rate	50 Hz
Equivalent Square Wave Duration	4.8 μ s
Rise Time 10 - 90 %	700 ns
PFN	four lines parallel, each line ten sections
PFN Impedance	1.34 Ω
Total Capacitance	1.8 μ F
Capacitor Capacitance	45 nF
Coil Inductance	1.3 μ H
Charging Voltage	50 kV max.
Peak Current (primary side)	16 kA
Pulse Transformer Ratio	1 : 23

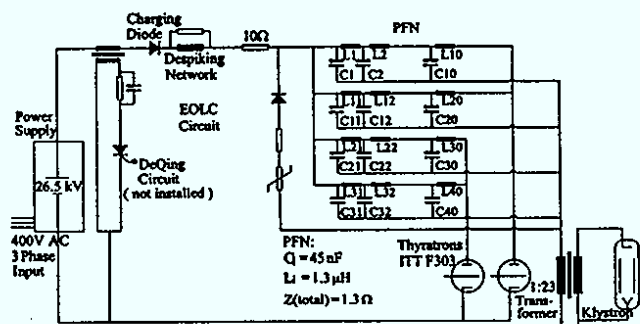

Figure 1: Basic circuit diagram

The pulse forming network is formed by four parallel lines of ten sections. They are discharged by two thyratrons, ITT F303, via the pulse transformer into the klystron. There is a slight positive mismatch between the pulse forming network and the klystron. The capacitors of the lines are charged by a resonant charging system consisting of a DC power supply (26.5kV, 5A), a charging choke of 16H and a charging diode capable to withstand

80kV. The PFN can be charged up to 50kV by a sinus half wave current of 17ms duration. This allows to operate the modulator at a repetition rate up to 50Hz. The DeQing system shown in the figure 1 was not installed, because the DC power supply has good regulation properties, which already allow a pulse to pulse variation smaller than 0.5%. Figure 2 shows typical waveforms at more than 500kV.

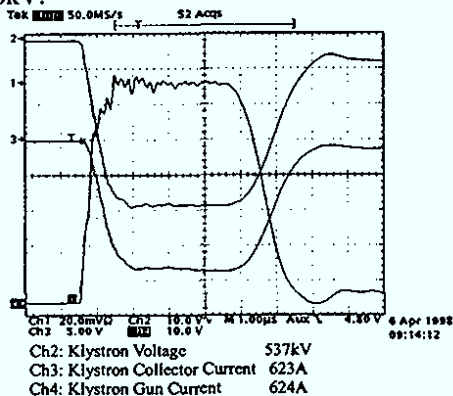

Figure 2: Typical waveforms

More detailed information can be found in [1].

3 OPERATION EXPERIENCE

At the beginning of operation electromagnetic noise generated by the modulators was a major concern. It entered the interlock system or other components and could lead to interruptions of the modulator operation. In the worst case it could even muddle up the thyatron driver trigger logic and damage components in the driver, especially the drivers thyristor switches. Since the source of noise could not be eliminated, we installed RC filters in the drivers and also in other components, which were affected by the noise. This solved our problem and allowed to operate without interruptions.

It is necessary to control the thyatrons reservoir voltage carefully. Otherwise the situation can occur, that instead of firing both thyatrons simultaneously, the thyatrons fire at different times or in the worst case one thyatron fails to fire. This does not harm the klystron, but leads to large thyatron grid spikes and can damage the thyristor switches in the driver circuits.

Besides these we had no major problems.

The klystron output power of 150MW could be reached with a cathode voltage of 550kV. With a PFN charging voltage of 50kV even 610kV could be achieved at the klystron. At this voltage an output power of 213MW could be extracted from the klystron. Since the klystron was developed for an RF power of 150MW at 3μs pulse duration and a repetition rate of 50Hz, we reduced the RF and HV pulse duration to 1μs and the repetition rate to 12.5Hz. The reduction in pulse width was accomplished by removing five capacitors per PFN line. At a flat top pulse duration of 1μs a maximum voltage of 610kV at 780A, which corresponds to a power of 475MW, was

achieved and could be handled without problems. Longer pulses might be even possible but have the risk of damaging the klystron or the modulator. Since we need the klystron to operate the test facility linac, we refrained from running at longer pulse width at this power level.

4 MODIFICATION

The second modulator was modified in order to investigate the properties of a constant current capacitor charging power supply. This type of power supply might be able to replace the resonant charging method. It charges a pulse forming line with a constant current to the desired voltage without the use of a charging choke. Maxwell (San Diego, USA) offers power supply modules up to a voltage of 50kV and a power rating of 10kJ/s. Modules can be connected in parallel to build one power supply with more output power. In a first stage we installed three modules, which are sufficient to operate the modulator at maximum peak power, but at a reduced repetition rate of 12.5Hz instead of 50Hz. In a later stage the new power supply could be upgraded to full average power by installing up to twelve modules in parallel. In the meantime the existing resonance charging system must be used, if operation at 50Hz repetition rate is required. Therefore all modifications of the existing modulator needed to be done in a way, which allows to switch easily between the two charging methods.

A freewheeling diode and two series resistors must be installed between the pulse forming network and the constant current charging power supply output. This is necessary, because the charging power supply must be protected from negative voltage at its output. In this case a current could flow through the power supply rectifier diodes, which might exceed their capabilities. Negative voltage at the power supply output arise during fault conditions like klystron arcing or PFN breakdown and even also during normal operation conditions. The EOLC diode is not sufficient to protect the power supply, because it does not connect the power supply output and ground. We therefore installed a another diode at the thyatron side of the PFN. Figure 3 shows the diagram of the modified circuit.

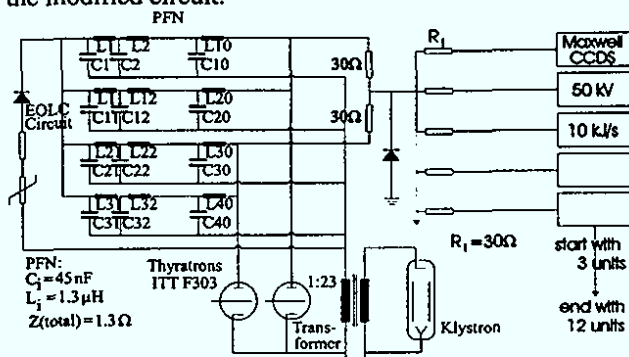

Figure 3: Diagram of the modified circuit

The protecting diode is made of 25 high voltage diodes in series (4kV each), each with a varistor in parallel. Two 30 Ω series charging resistors serve for the decoupling of the two thyratrons. This allows switching of both thyratrons at the same time. Each of the power supply modules has a separate output cable, which is terminated by a another series resistors. We did not combine the output of modules directly after the output and did not use just one cable and resistor instead of many, because this would have made it more difficult to install or remove modules for test purposes. For a set up, which does not require this flexibility, a connection with just one cable could of course be made. The protecting diode and the resistors were installed in the PFN cabinet.

The compact size of this new type of power supply makes it attractive if space availability is an important aspect, e.g. in the case of a linear collider tunnel. The size of each of the modules in use is 220mm high, 508mm long and 19 inch wide. All modules, which would be sufficient for a modulator operation at full average power, would fit in two 19 inch racks. This reduces the space required by the existing DC power supply and the charging unit by about a factor of ten.

Another motivation to test the new type of power supply results from the efficiency demands of a linear collider. The existing resonance charging method has an efficiency of 88% for the charging path from the mains to the PFN, partly caused by the DC power supply efficiency and partly caused by ohmic and eddy current losses due to the charging choke. We measured the efficiency of the power supply at various output voltage settings. At the maximum voltage of 50kV it reaches 93%. Even if one includes the losses in the series charging resistors, the efficiency for the charging path from the mains to the PFN is still 91.5%.

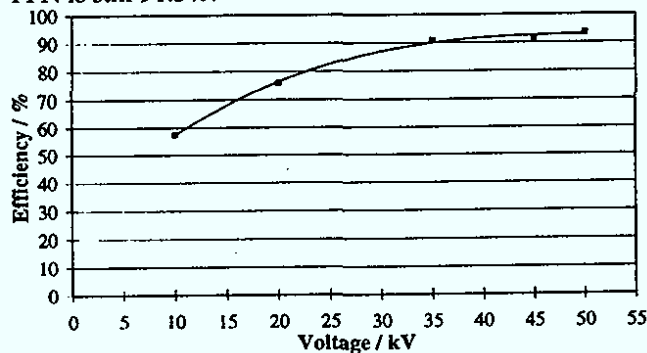

Figure 4: Charging power supply efficiency versus PFN voltage

The pulse to pulse variation was measured in the same way as for the resonance charging method by superposing 1500 klystron voltage pulses. The variation did not change significantly, and is still smaller than 0.5%.

An important aspect for a linear collider is the impact of the modulator power supplies on the line. Therefore we measured the voltage and the current of each of the input

phases and calculated the input power of each phase. Figure 5 shows the linear ramp of the PFN voltage and the power extracted from the three phases of the mains. It is basically a picture one would expect from a three phase double way rectifier, which has do provide a linear increasing output power. This process is repeated with the modulators repetition rate. The power consumption from the mains is not constant and in case of a large number of modulators would probably disturb the mains. Further development to limit this effect is required.

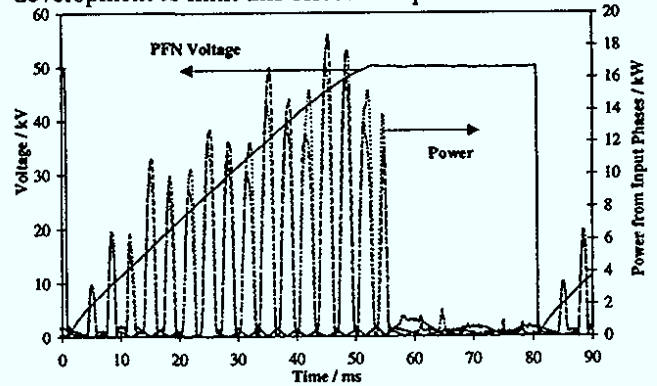

Figure 5: Charging voltage and power extracted from the three phases of the mains during one charging cycle

More detailed information about the modification of the second modulator can be found in [2].

5 CONCLUSION

The high voltage pulse modulators at the S-band test facility are in operation at nominal conditions of 550kV at 3 μ s pulse duration and a repetition rate of 50Hz. The second system can be even operated at a higher power level up to 475MW (610kV, 780A) at 1 μ s pulse duration and 12.5Hz repetition rate. The operation of the modulators is reliable, but the thyatron reservoir voltage setting needs careful control and adjustment. A new type of charging power supply was installed at the second system. It has a high efficiency and is of compact size, which makes it attractive for linear collider applications. Its reaction to the mains was investigated, but further work is necessary to limit disturbing effects to the mains.

6 REFERENCES

- [1] S. Choroba, M. Bieler, J. Hameister, Y. Chi, A 375MW Modulator for a 150MW Klystron at the S-Band Linear Collider Test Facility at DESY, Proceedings of the XVIII International Linear Accelerator Conference, Linac96, Geneva, Switzerland, 26 -30 August, 1996, P 785-787
- [2] S. Choroba, J. Hameister, M. Kuhn, "Operation of a HV Pulse Modulator at the S-Band Test Facility at DESY with a Constant Current Capacitor Charging Power Supply", to be published in the Proceedings of the 1998 Third Modulator-Klystron Workshop, SLAC, Stanford, June 29 - July 2, 1998