

REAL-TIME BEAM LOADING COMPENSATION FOR SINGLE SRF CAVITY LLRF REGULATION

I. Rutkowski, M. Grzegorzółka WUT, Warsaw, Poland
 L. Butkowski, C. Schmidt, DESY, Hamburg, Germany
 M. Kuntzsch, HZDR, Dresden, Germany

Abstract

Stable and reproducible generation of a photon beam at Free Electron Lasers (FELs) necessitates a low energy spread of the electron beam. A low level radio frequency (LLRF) control system stabilizes the RF field inside accelerating modules. An electron beam passing through the cavity induces a voltage proportional to the charge and the cavity shunt impedance. The feedback loop tries to compensate for the perturbation after the accelerating gradient drops. The delay and high gain result in an overshoot or oscillations during transients. A feed forward signal can be applied to act on the plant simultaneously with the RF feedback. It can be generated off-line based on system characteristics and beam parameters or on-line using information obtained from the beam diagnostic systems. In the latter scheme fluctuations of the beam current are accounted for in real-time using an open-loop (feedforward) controller. The bunch charge detection scheme and its implementation is described. This paper describes results of the tests performed on the ELBE (Electron Linac for beams with high Brilliance and low Emittance) radiation source at the HZDR (Helmholtz-Zentrum Dresden-Rossendorf) facility using a MTCA.4-based LLRF control system.

INTRODUCTION

Stable and reproducible generation of a photon beam at Free Electron Lasers (FELs) necessitates a low energy spread of the electron beam. A low level radio frequency (LLRF) control system stabilizes the RF field inside accelerating modules. An electron beam passing through the cavity induces a voltage proportional to the charge and the cavity shunt impedance. For an SRF cavity with a high loaded quality factor (Q_L) compensation of the beam loading may require more RF power to be provided than is required to sustain the field gradient in the cavity, making it a major source of distortion of the RF field. Waveforms from a MTCA.4-based digital LLRF system using only a PI feedback controller are shown in Fig. 1 (gain in arbitrary units).

The doubling time of the integral controller is significantly longer than the pulse length (4 ms). Increasing the gain decreases the static error during the beam pulse, but results in transient oscillations (see Fig. 2). A feed forward signal can be applied to act on the plant simultaneously. It can be generated off-line based on system characteristics and expected beam parameters or on-line using information obtained from the beam diagnostic systems. It has been demonstrated [1] that real-time beam loading compensation

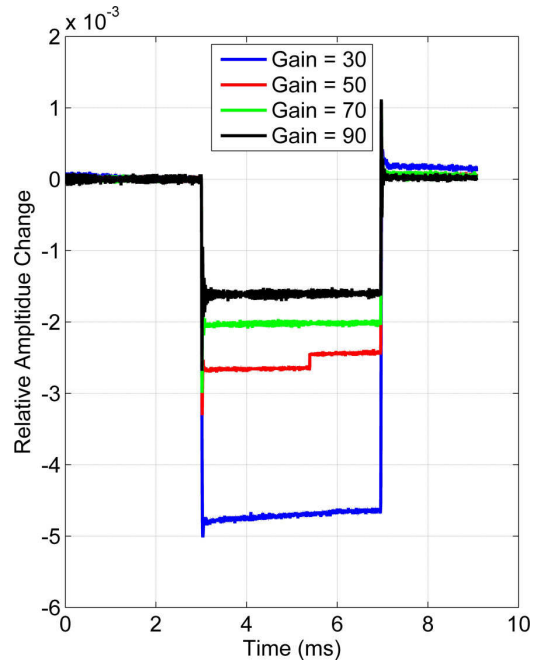

Figure 1: Response of a LLRF system using only a PI feedback controller to a beam pulse.

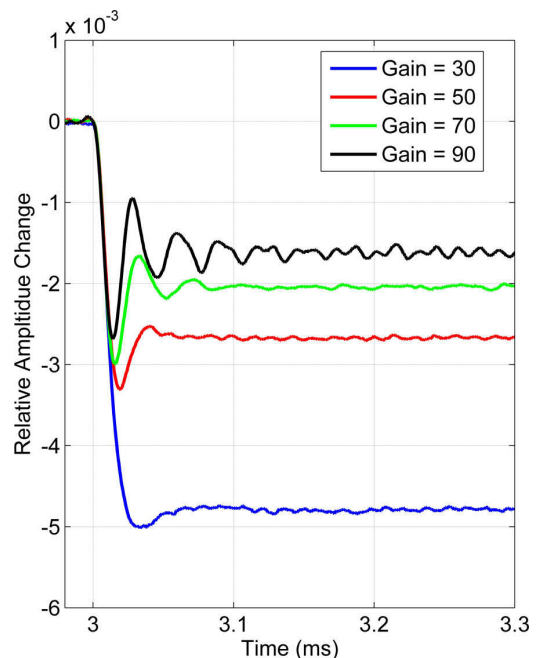

Figure 2: Response of a LLRF system using only a PI feedback controller to a beam pulse (zoom in during beam rise).

Pre-Press Release 23-Oct-2015 11:00

Copyright © 2015 CC-BY-3.0 and by the respective authors

(BLC) scheme reduces the bunch-to-bunch energy spread compared to control scheme using the PI controller only.

DETECTION HARDWARE

The bunch charge can be detected using various instruments. For real-time operation a non-destructive scheme is necessary. At ELBE facility an Integrating Current Transformer (ICT) is used. The signal at the output of the ICT is broadband and has low amplitude, resulting in low SNR. A high-gain, wideband amplifier is used to condition the signal. Very short rise and fall times make direct sampling of the signal impractical.

For beam-loading compensation only the information about signal's amplitude is necessary. A peak hold detector with a reset circuit can be used to sample the amplitude. The precise timing information is lost, but requirements for an analog-to-digital converter (such as bandwidth, maximum sampling speed, and aperture jitter) are lessened. The block diagram of the circuit used in this project is shown in Fig. 3.



Figure 3: Block diagram of the peak detector.

The input signal charges a capacitor through a fast Schottky diode and a series 50 Ohm resistor which provides matching during signal transients. The voltage in the capacitor is buffered using a low input bias current operational amplifier. A fast bipolar junction transistor discharges the capacitor after the peak value is sampled. The discharge signal is synthesized from the accelerator's reference signal and shifted by appropriate number of cycles. Waveforms of the peak detector's output signal sampled by a high-speed real-time oscilloscope for various bunch charges are presented in Fig.4.

For charge below 30 pC the signal is disturbed by strong oscillations during the first 15 ns after the rising edge. The transfer function of the system (voltage -> bunch charge) was characterized by relating the mean value of the signal (in time period 35 to 45 ns) to the known bunch charge using linear regression (Fig. 5).

The estimated model equals

$$Q = 0.1044 \frac{pC}{mV} * (V + 158.13)(mV) \quad (1)$$

The charged (Q) is lineary proportional to the measured voltage (V) with a roughly 158 mV offset. The maximum

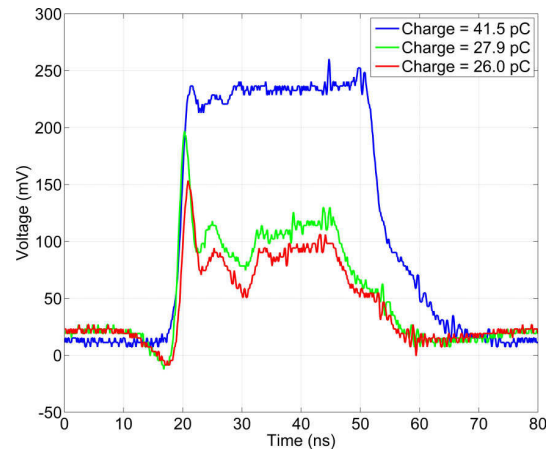

Figure 4: Detector's output signal.

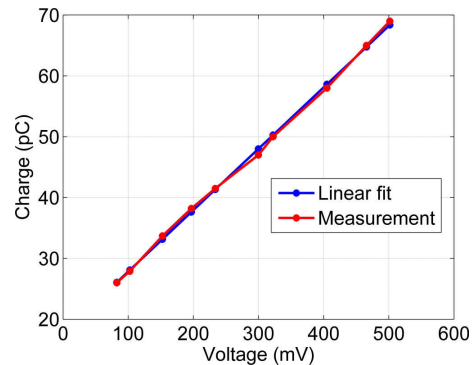

Figure 5: Characteristic of the bunch charge detection subsystem.

estimation error is 0.73 pC and mean absolute estimation error is 0.41 pC. The measurements prove the detection subsystem can be considered linear.

FIRMWARE

The charge detector output signal feeds the MTCA.4-based single cavity LLRF regulation system [2]. This system consist primarily of an Advanced Mezzanine Card digitizer SIS8300-L2¹ and an analog Rear Transition Module DRTM-DWC8VM1².

An outline of the controller's algorithm is given in Fig.6. First, the RF feedback loop is described. Sampled IF signals from ADCs are fed into delay blocks, allowing coarse time alignment of different channels. In the next step IQ demodulation and calibration are performed. A programmable IIR filter is typically used as a low-pass or band-gap, limiting the detector noise and suppressing undesired spectral components like other pass-band modes of the cavity. The calculated error signal is fed to the feedback controller, the output of which is limited, before being combined with feed-forward signal. The drive signal is then scaled and rotated to compensate the slow drifts of the system, providing the controller with constant operating conditions. Finally, offset compensation is performed.

Raw ADC samples of the bunch charge detector output signal are fed into a block detecting the maximum and mini-

¹ <http://www.struck.de/sis8300-12.html>

² <http://www.struck.de/dwc8vm1.html>

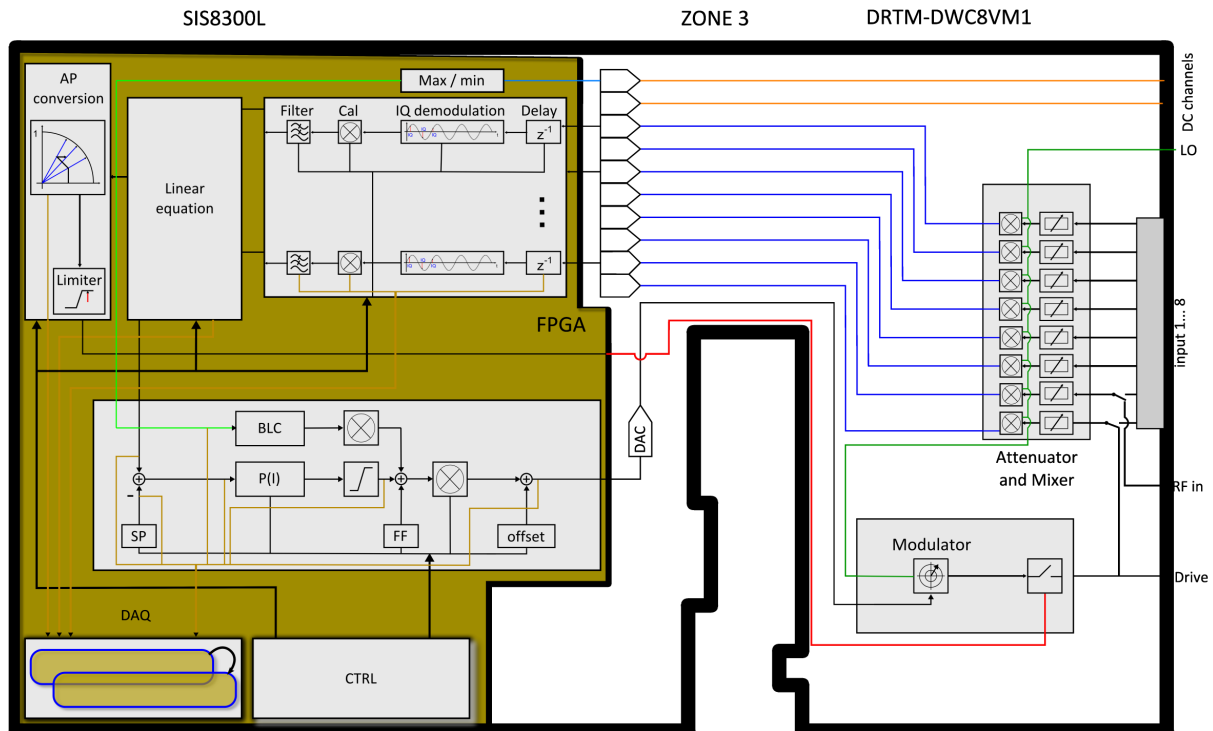

Figure 6: Hardware and firmware block diagram of the LLRF controls.

imum values. The amplitude (difference between max and min values) is multiplied by a gain coefficient. The next step is the rotation on the IQ plane. This signal is combined with feedforward and feedback signals before the output rotation.

TESTS

Measurements of the MTCA.4-based digital LLRF system using a PI feedback controller and the real-time BLC are shown in Fig. 7 (gain in arbitrary units). The beam pulse shape is similar to the one presented in Fig. 1 and 2.

Gain factor and rotation angle were chosen experimentally. The system response to beam rise is smooth, with no visible distortions. After the beam disappears, the RF field oscillates starting with the initial spike independent of the PI controller gain as visible in Fig. 7.

CONCLUSION

The addition of the real-time BLC to the LLRF system improves the system response to beam transients. Further development is needed to improve hardware (offset reduction by using different type of peak detector) and implement new algorithms in software (automated estimation of gain factor and rotation angle). The field oscillation at the end of the beam-body should be reduced.

REFERENCES

[1] E. Vogel, et al., "Beam loading compensation using real time bunch charge information from a toroid monitor at FLASH," in *Proc. of the 22nd Particle Accelerator Conf.*, Albuquerque, New Mexico, USA, pp. 2074-2076, June 2007.

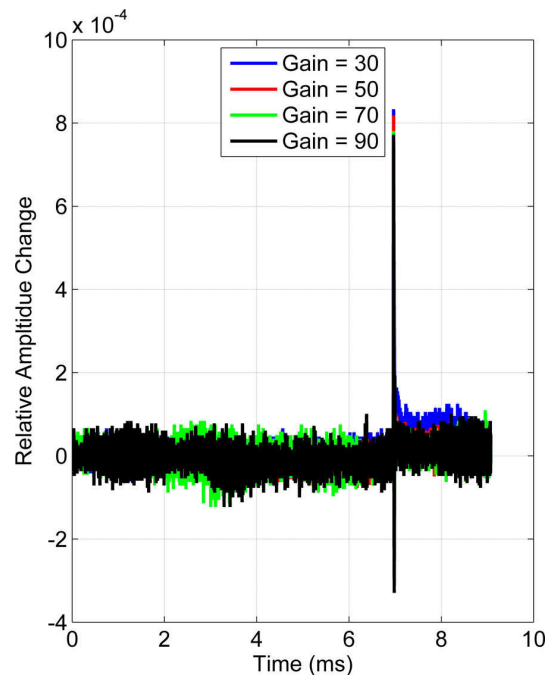

Figure 7: Response of a LLRF system using the PI feedback controller and the real-time BLC to a beam pulse.

[2] I. Rutkowski, et al., "MTCA.4-based digital LLRF control system for CW SRF Linacs," submitted for publication.