

PROJECT "PETRA"

G.-A. Voss and K. G. Steffen

Deutsches Elektronen-Synchrotron DESY, Hamburg, Germany

The PETRA project being constructed at Hamburg is a 19 GeV electron-positron storage ring that surrounds the DESY laboratories at a length of 2.3 km. The ring has an eightfold symmetry, and there will be up to 4 bunches circulating in each ring (Fig. 1). Four short straight sections will be initially used for experiments. Of the four long straight sections, two (N and S) will hold the rf accelerating structure, and two (E and W) will later be also available for experiments. The corresponding 6 experimental halls are already being constructed. Injection will be at 7 GeV from the DESY synchrotron, using the DORIS storage ring as an intermediate beam collector.

Lattice, Optics

One octant of the machine consists of a normal separate function cell structure in the arc, surrounded by half a short and half a long straight section of about 25 m and 46 m length, respectively. The normal cell is shown in Fig. 2. The last cell at each end of the arc is modified in order to facilitate dispersion matching and provide space for injection magnets. The cells around the center of the arc, normally six of them, are powered as a periodic FODO-channel, while the quadrupoles toward the ends of the arc have different strengths for matching the dispersion to become identically zero in the short and in the long straight sections. This is necessary to avoid an excitation of synchrotron-betatron coupling resonances by the rf cavities and a separation of the two beams at the interaction point if the cavities are asymmetrically distributed and the radiation loss between cavities is non-negligible.

By varying the focusing strength in the normal cell, the dispersion can be varied in a wide range while still keeping it matched to the zero dispersion straight sections. In an effort to explore the limits of variable tune, several optics were developed and tested in particle tracking programs. Momentum compaction was varied by a factor of 7, and emittances by a factor of 30. Typical examples are given in the following table:

amplitude functions at I.P.	vert.	0.27 m	0.3 m	0.31 m
	hor.	2.7 m	4.2 m	5.0 m
max. dispersion in normal cell		6.3 m	2.1 m	0.5 m
momentum compaction		$7.5 \cdot 10^{-3}$	$3.3 \cdot 10^{-3}$	$1.0 \cdot 10^{-3}$
natural beam emittance (rad·m)		$37 \cdot 10^{-10}$	$7.9 \cdot 10^{-10}$	$1.2 \cdot 10^{-10}$
max. amplitude functions		< 250 m		

replacing for example, four of the standard bending magnets. Each of these units consists of 3 dipole magnets of alternating polarity which give a strong local bending to the beam and thus increase the damping rates and the beam emittance.

In the long straight sections, beam envelopes are kept small by a sequence of quadrupoles which, in the two rf sections, are interlaced with the rf cavities. In order to avoid excessive Q-shifts by bunch-bunch interaction in the center of these sections, the ratio of amplitude functions is made there about equal to the ratio at the experimental interaction points.

Special weak bending magnets will be installed at each side of the short experimental straight sections; they serve to reduce, by a factor of 6, the critical energy of the synchrotron light that shines from the bending magnets into the interaction region. There remains, however, the comparable synchrotron radiation background from the large interaction region quadrupoles.

In initial PETRA operation, the free straight section length for experiments will be 15 m. The large aperture quadrupoles on either side will be spaced 4 m apart from each other, giving room for a pair of electrostatic separators. These separators produce a local beam bump and bypass the beams at injection. Similar pairs of separators will be installed in the long straight sections, also.

In searching for the optimum sextupole configuration for chromaticity compensation, the variation of the working point in a momentum range of $\pm 1\%$ was minimized by varying the strengths of 4 different families of sextupoles. Then, by adding two more groups of sextupoles, the stable machine acceptance was optimized, using a particle tracking program.

In order to study the effect of magnet errors on the vertical dispersion and beam emittance, an optics simulating program was developed that, in the presence of sextupoles, finds the horizontal and vertical closed orbit displacement, determines the coupled linear optics along this closed orbit and calculates the emittance for each of the two betatron oscillation modes in the coupled machine.

Magnets, Installation

All PETRA magnet cores are made of punched steel laminations, 1.5 mm thick. They are stacked between precision contoured end plates on a stacking fixture. After compressing the stack, a steel shell is welded onto its outside, bonding it into a self-supporting unit. The end plates carry chamfers for linearizing the integrated end field, as determined by model measurements. As an exception, only the sextupole magnet has no end plates, and its core stacks are glued instead of welded.

The magnet coils are made of hollow aluminium conductor, insulated with a mylar- or glass fibre-epoxy compound.

Fig. 3 shows the bending magnet cross section. It is a C-magnet with parallel pole faces carrying a shimming nose at each side. The pole width is 200 mm and the gap height is 70 mm. The 3 sheets forming the supporting box are welded to the laminations only at the front side of the magnet, thus introducing no thermal stresses into the sensitive part of the yoke.

The 4 quadrants of the standard quadrupole magnet are separately stacked, welded, assembled with the coil and then bolted together, being centered by dowels. Thus, the magnet can be split in halves for inserting the vacuum chamber. The diameter between poles is 100 mm.

The high beta quadrupoles have an aperture of 160 mm and are of similar design. However, their quadrants are welded together, and the vacuum chamber must be inserted through the aperture.

The sextupole magnet is, after relative alignment, rigidly attached to the quadrupole and can also be split in halves for vacuum chamber insertion.

In the ring, the bending magnets are supported on two screws at each end. The quadrupole-sextupole units have their own stand that supports them at 3 points. Transverse alignment of all magnets is done by laser

magnets are moved in on special trolleys.

All cables, current leads and cooling water pipes are supported along the outer tunnel wall. Magnet power distribution is done with aluminum bus bars. There are about 20 magnet circuits that can be independently powered. The total magnet power at 19 GeV is 5-6 MW. All major power supplies are available from existing DESY facilities.

Vacuum

In designing the vacuum chamber, great care has been taken to present a smooth inner surface contour to the beam. This is necessary since, with a bunch length as small as 3 cm, all discontinuities in the chamber would lead to higher order mode losses that would cause local heating and would quickly add up to consuming an excessive fraction of the total rf power. Furthermore, they might induce phase instabilities. Therefore, prototypes of all beam line components are being tested by the so-called wire measurement. In this measurement, a 60-100 ns pulse is passed through the sample chamber on a wire along the beam line, and the degradation of this pulse permits to calculate the higher order mode losses and the longitudinal wall impedance.

The vacuum chamber in the normal cell, made of extruded aluminum alloy, is shown in Fig. 4. It has 3 separated apertures: the central aperture for the beam, the outer cooling water channel for the synchrotron light absorption, and the inner aperture for distributed ion sputter pumping. In the bending magnet, the wall between the pumps and the beam is perforated by spark erosion. On the other hand, in the region of the quadrupole and sextupole the pumping section is out of. Thus it is possible to extend a single vacuum chamber, 7.2 m long, through a complete half cell, with no steps seen by the beam and with no interruption in the cooling water channel. Even the electrostatic beam position monitor plates are carefully hidden in the chamber wall.

The design of the chamber joints presents a particular problem; they must be smooth, give good rf contact and permit a longitudinal motion of several cm. We have chosen a solution that consists of two forged and carefully machined aluminum parts which slide into each other over an rf contact spiral. On the outside, a stainless steel bellow is welded between the aluminum collars, using a special welding technique developed at DESY.

The machine will be subdivided into vacuum sections by 32 gate valves. In the open position, these valves will carry a dummy simulating the chamber contour. The total installed pumping speed will be 250 000 l/sec, of which more than half is due to distributed pumping. The distributed pumps will work at energies as small as 3 GeV; this is achieved by building part of the pumping cells with an increased diameter. 250 holding pumps with a pumping speed of 30 l/sec will be distributed around the ring. Provisions for baking the chamber at 150°C are being made, but we expect that glow discharge cleaning will normally be sufficient for reaching the working pressure in the range of 10^{-9} to 10^{-8} torr. The expected lifetime of the beam is 4-10 hours.

Radiofrequency system

The frequency of the PETRA rf system is 500 MHz, leading to a theoretical bunch length of the order of 3 cm. With such short bunches, the parasitic higher order mode losses are rather severe, and it has therefore been seriously discussed whether we should go to an 80 MHz rf system instead. A detailed comparison of the two systems, however, shows that, for a total power of 4.4 MW, the cost of the 80 MHz system is 50 % higher and the gain in luminosity is very small. It has been found that the higher order mode (h.o.m.) losses in the rf cavities are not as high as originally assumed. Including a correction factor for the beam aperture, more recent calculations predict, in agreement with wire measurements, an effective h.o.m. impedance of $R_{h.o.m.} = 1.2 \text{ M}\Omega$ per cell at 500 MHz. The total h.o.m. impedance of the remaining vacuum chamber is estimated to be 75 M Ω .

unit is made of copper, electron beam welded, and consists of 5 inductively coupled cells. The unit is fed from the middle and has 2 tuning plungers. An aluminum prototype was tested up to 140 kW c.w. without multipactoring. The rf accelerating unit is shown in Fig. 5.

The total rf power of 4.4 MW is generated by 8 narrow band klystrons with an efficiency of 60 %. In feeding the cavities, the power from 2 klystrons is added, passed through a 1.2 MW circulator and is then distributed by a waveguide system into up to 16 accelerating units. In the fully equipped ring, there will be up to 64 accelerating units with a total shunt impedance of 1200 M Ω .

Luminosity

The PETRA rf system will be built up in 3 stages. In autumn 1978, when the assembly of the ring will be completed, there will be 16 cavity units installed with an available total power of 2.2 MW, leading to a maximum energy of 15 GeV (Fig. 6). In 1979, we will have 32 cavity units installed at full power, giving a maximum energy of 17.5 GeV. The later addition of another 32 cavity units will finally move the maximum energy up to 19 GeV.

Assuming that, below the rf limit, the beam emittance is kept at a constant value of $2.4 \cdot 10^{-7}$ rad·m, using wiggler magnets or variable tune, the luminosity rises with the square of the energy and, with 32 cavity units, reaches its maximum value of $0.8 \cdot 10^{32} \text{ cm}^{-2} \text{ sec}^{-1}$ at an energy of 14.5 GeV. At this energy, with 4 bunches and 17 mA per bunch in each beam, 60 % of the total power goes into the beams, 22 % are cavity losses at 500 MHz, and the remaining 18 % are higher order mode losses in the cavities and the ring. Going to higher energies, the rf-limited branches of the luminosity curves assume that the number of bunches per beam gradually decreases from 4 to 1. The corresponding branch for an 80 MHz system is also shown in Fig. 6.

Injection, Controls

At the injection energy of 7 GeV, the damping time in PETRA is 100 msec, allowing injection only in every tenth synchrotron cycle. When using the DORIS storage ring as an intermediate positron collector, not only this factor of ten can be gained, but also another factor of 30 by having 30 bunches simultaneously filled and stored in DORIS. A fast kicker in DORIS - then operating at 2.2 GeV in a single ring mode - will re-transfer single accumulated bunches into the synchrotron where they will be accelerated to 7 GeV and then injected into PETRA. With programmed phasing and timing, any desired bunch sequence can thus be filled in PETRA. For the maximum current of 70 mA, the positron filling time is less than 5 minutes. Experimental work at DORIS will continue, being not severely affected by the PETRA injection.

All PETRA controls will be handled by a central computer system that is linked to substations in the halls through a serial data acquisition system (SEDAC). Some analog signal switching will also be controlled by this system. Power supplies, as in DORIS, will be varied by presetting slopes and applying a common clock line. The central computer site comprises three "Nord 10" computers and three identical consoles with colour display, tracker ball and knob, touch panel and key board. There will be a high speed data link with the central DESY computing facility.

Status

The PETRA proposal was submitted in November 1974, and the project was authorized in October 1975. The construction is now well under way and in accord with the planned completion of machine

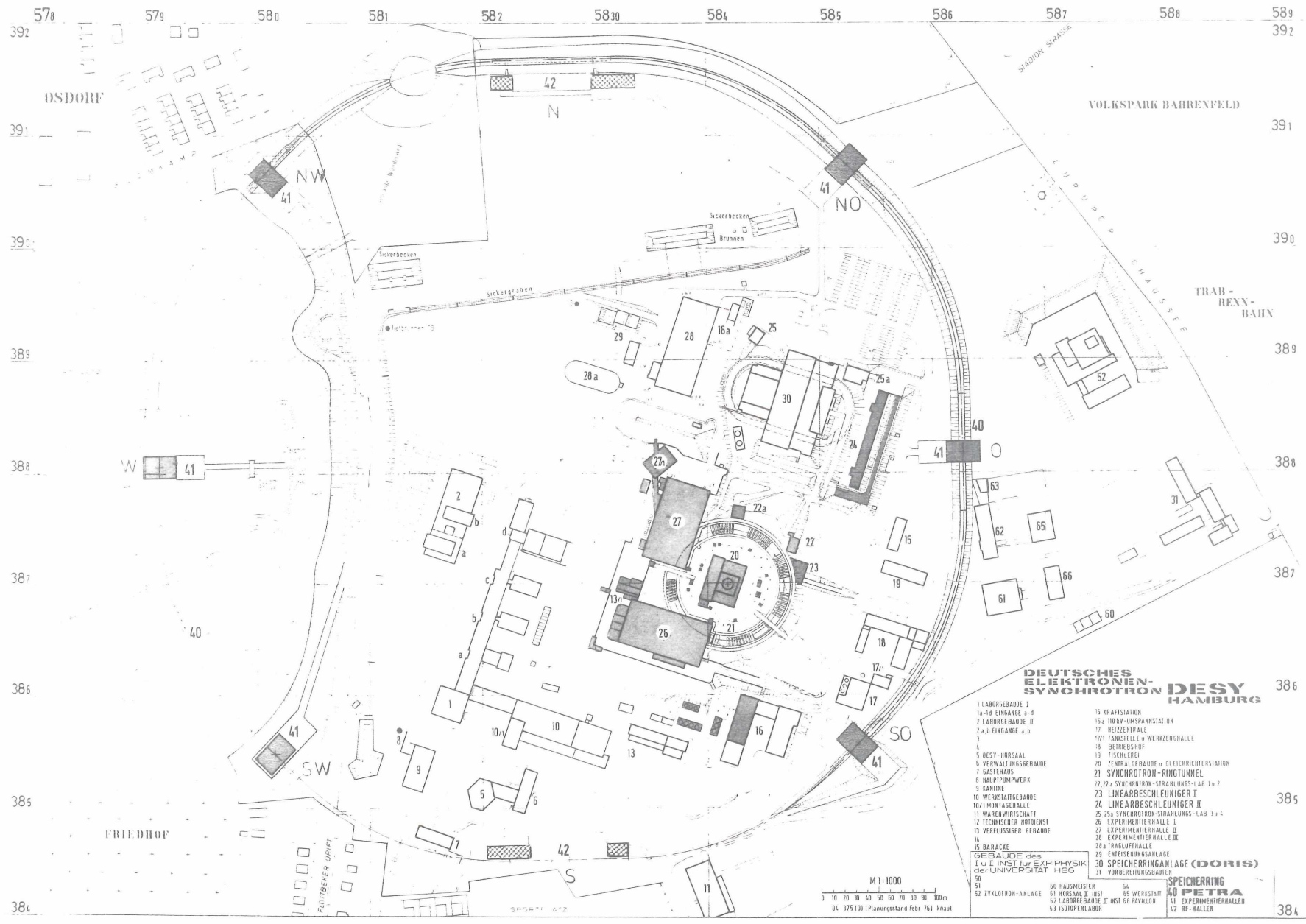

- DEUTSCHES ELEKTRONEN-SYNCHROTRON DESY HAMBURG**
- 1 LABORGEBAUDE I
 - 1a-1d EINGANGE a-d
 - 2 LABORGEBAUDE II
 - 2a,b EINGANGE a,b
 - 3
 - 5 DESY-HORSAAL
 - 6 VERWALTUNGSGEBAUDE
 - 7 GASTHAUS
 - 8 HAUPTPIPPWERK
 - 9 KANTINE
 - 10 WERKSTÄTTENGEBAUDE
 - 10/1 MONTAGEHALLE
 - 11 WARENWIRTSCHAFT
 - 12 TECHNISCHER WIRTSCHAFT
 - 13 VERFLUSSIGER GEBAUDE
 - 14
 - 15 BARACKE
 - 16 KRAFTSTATION
 - 16a 110 kV-UMSPANNSTATION
 - 17 REZEPTPISZE
 - 17/1 TANKSELLE u. WERZEUGHALLE
 - 18 BETRIEBSHOF
 - 19 TISCHLEGER
 - 20 ZENTRALGEBAUDE u. GLEICHRICHTERSTATION
 - 21 SYNCHROTRON-RINGTUNNEL
 - 22, 22a SYNCHROTRON-STRAHLUNGS-LAB 1 u. 2
 - 23 LINEARBEACHTLUNGER I
 - 24 LINEARBEACHTLUNGER II
 - 25 25a SYNCHROTRON-STRAHLUNGS-LAB 3 u. 4
 - 26 EXPERIMENTIERHALLE I
 - 27 EXPERIMENTIERHALLE II
 - 28 EXPERIMENTIERHALLE III
 - 29a TAGELUFTHALLE
 - 29b ERHEBUNGSANLAGE
 - 30 SPEICHERRINGANLAGE (DORIS)
 - 31 VORBEREITUNGSBÄNKE
 - 32 ZYKLOTRON-ANLAGE
 - 33 ISOPIPELABOR
 - 34
 - 35
 - 36
 - 37
 - 38
 - 39
 - 40
 - 41
 - 42
 - 43
 - 44
 - 45
 - 46
 - 47
 - 48
 - 49
 - 50
 - 51
 - 52
 - 53
 - 54
 - 55
 - 56
 - 57
 - 58
 - 59
 - 60
 - 61
 - 62
 - 63
 - 64
 - 65
 - 66
- GEBÄUDE des I u. II INST f.ur EXP. PHYSIK der UNIVERSITÄT HAMB.**
- SPICHERRING PETRA**
- 40 EXPERIMENTIERHALLEN
 - 41 EXP. HALLEN
 - 42 RP-HALLEN

Fig II 1

cell length 14 400

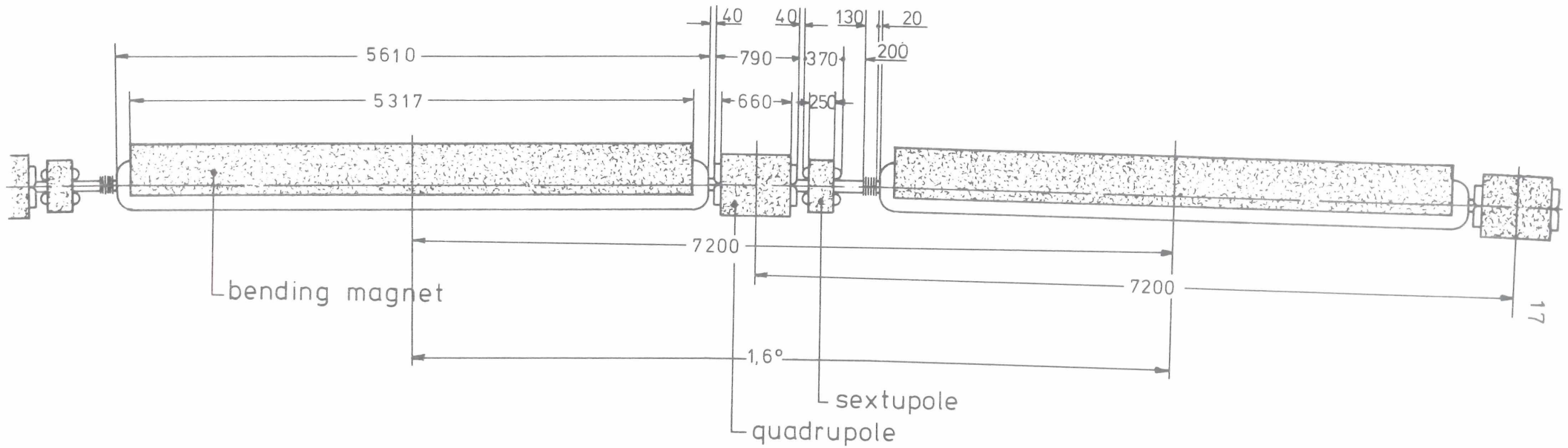

bending radius 192,05m

normal cell in PETRA

1 : 50

Fig IV.0 2

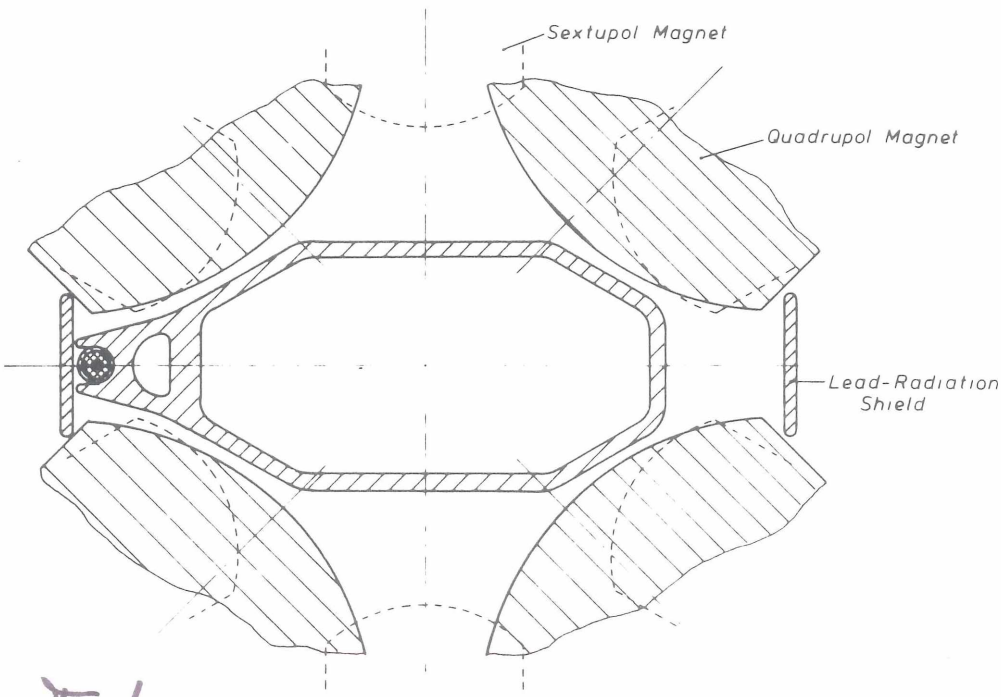
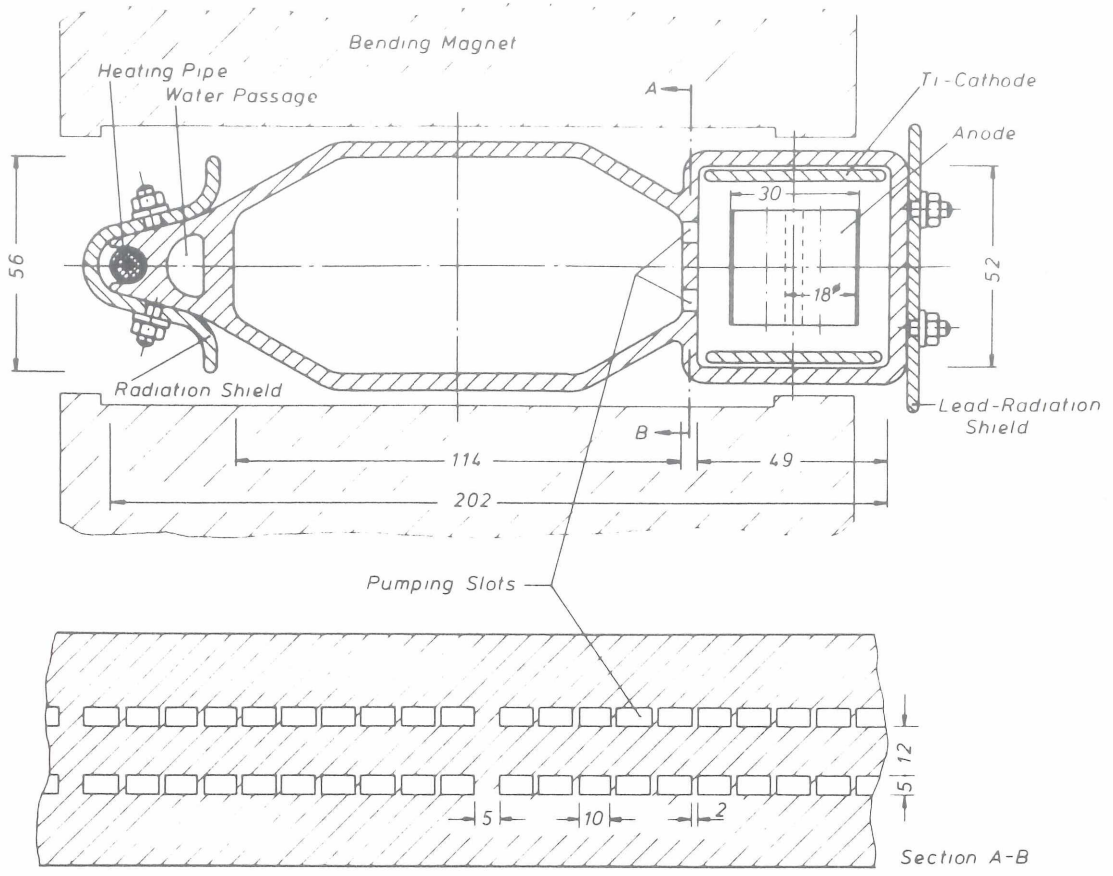
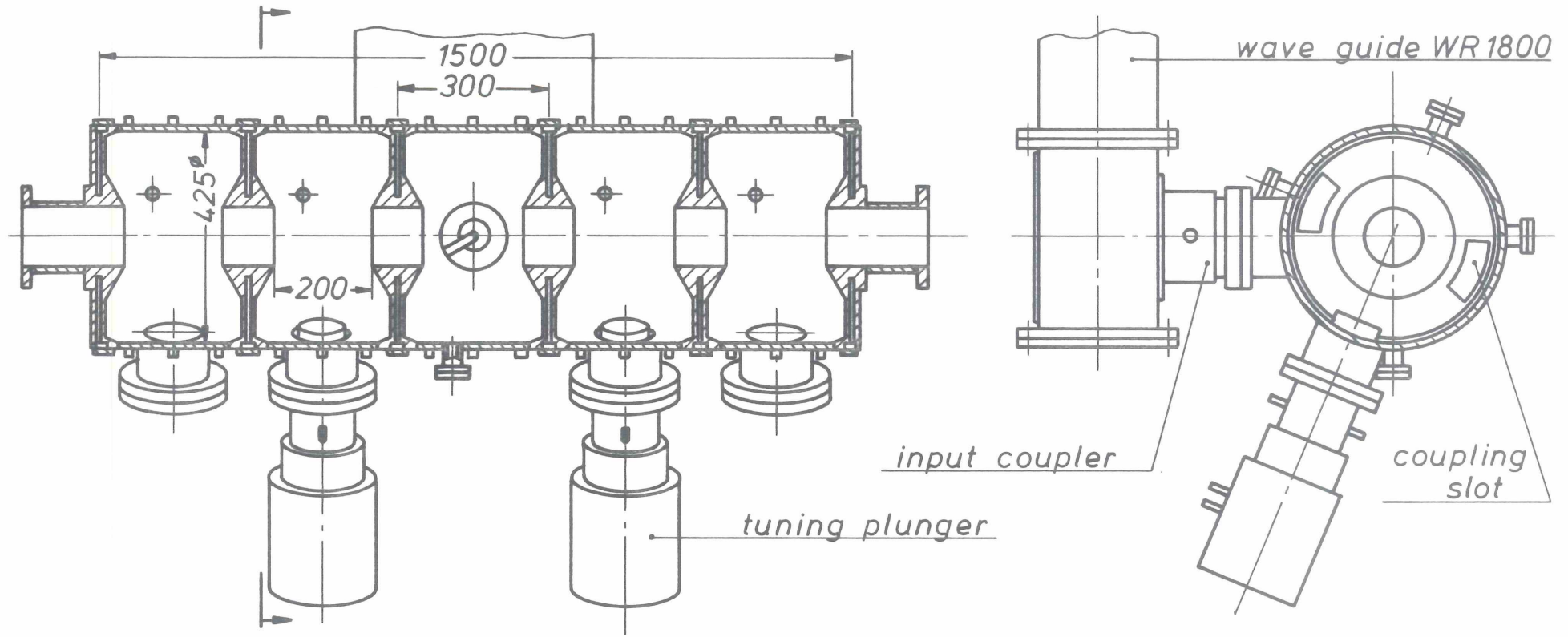

Fig. 4

Fig. V.1.

Cross Sections of the Vacuum-Chamber in the Magnets



PETRA Accelerating Structure

Shunt impedance $R_p = \hat{U}^2 / 2P_c = 12,5 \text{ M}\Omega/\text{m}$

Quality factor $Q_o = f_c / 2\Delta f = 33\,000$

Coupling $k = (f_o - f_\pi) / f_c = 1,07\%$

Tuning range $\Delta f_t = \pm 1 \text{ MHz}$

Material of structure: OFHC-copper

Tuning: inductive plunger

No. of tuning plungers: two

Coupling: two inductive slots

Input coupler: coaxial window

Fig. 5

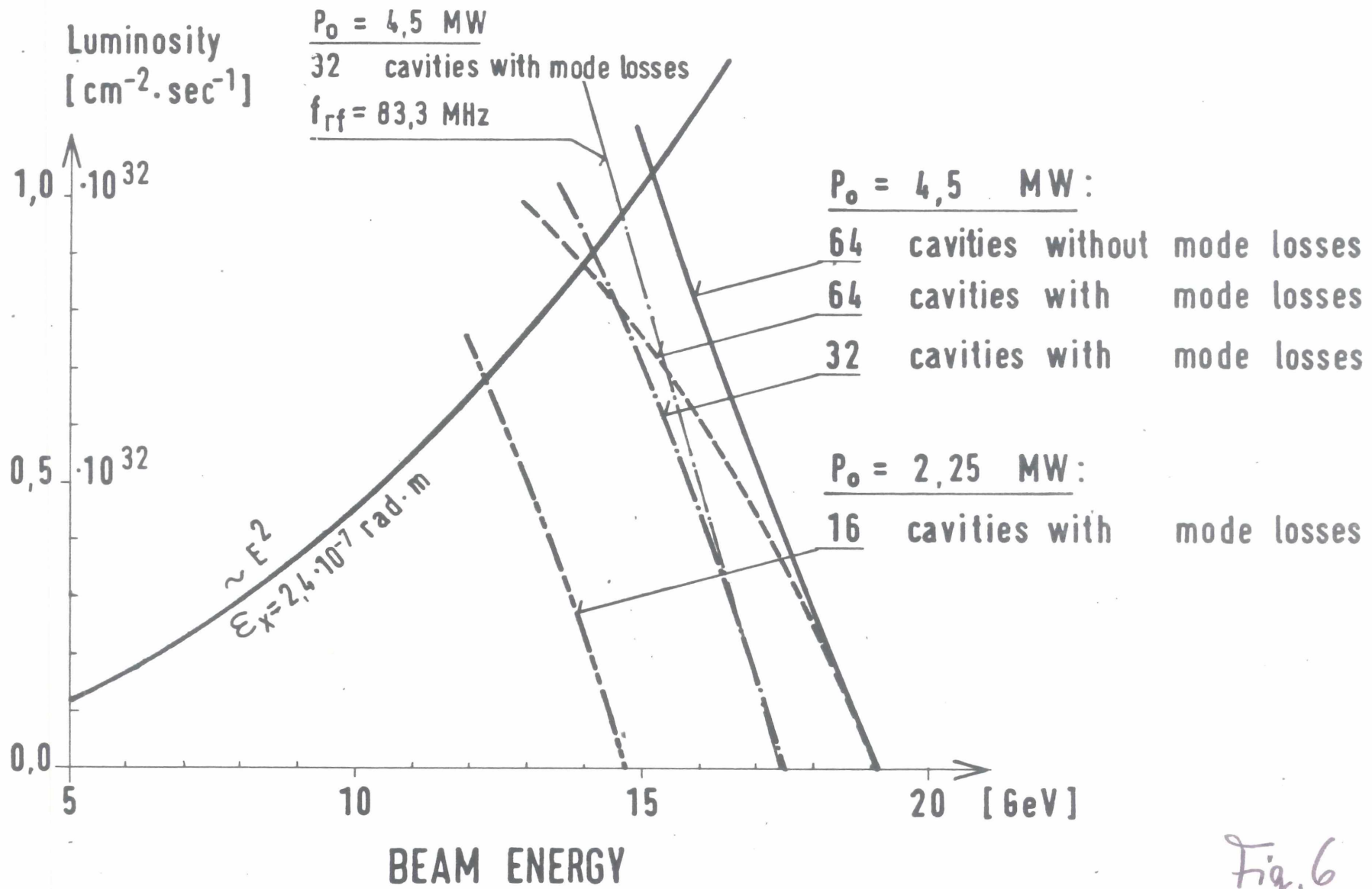

Fig. 6