

FEMTOSECOND TIMING DISTRIBUTION FOR THE EUROPEAN XFEL

C. Sydlo*, F. Zummack, M. K. Czwalinna, M. Felber, T. Lamb,
S. Schulz, Ch. Gerth, H. Schlarb, DESY, Hamburg, Germany
S. Jablonski, Warsaw University of Technology, Warsaw, Poland

Abstract

Accurate timing synchronization on the femtosecond time-scale is an essential installation for time-resolved experiments at free-electron lasers (FELs) such as FLASH and the upcoming European XFEL. To date the required precision levels can only be achieved by a laser-based synchronization system. Such a system has been successfully deployed at FLASH and is based on the distribution of femtosecond laser pulses over actively stabilized optical fibers. Albeit its maturity and proven performance this system had to undergo a major redesign for the upcoming European XFEL due to the enlarged number of stabilized optical fibers and an increase by a factor of up to 10 in length. The experience and knowledge gathered from the operation of the optical synchronization system at FLASH has led to an elaborate and modular precision instrument which can stabilize polarization maintaining fibers for highest accuracy as well as economic single mode fibers for shorter lengths. This paper reports on the laser-based synchronization system focusing on the active fiber stabilization units for the European XFEL, discusses the most recent performance results, which already meet the stringent requirements for operation.

INTRODUCTION

The optical synchronization system for the European XFEL will adopt to the greatest possible extent the proven and reliable system from FLASH. The long term experience with the optical synchronization system at FLASH has led to numerous enhancements and deeper understanding of the issues involved in such a complex and sensitive precision arrangement. Consequently, for the European XFEL an inimitable possibility arises to incorporate all the gathered knowledge from the bottom up into a new benchmark setting synchronization system.

A schematic representation of the synchronization system is shown in Figure 1. The master-oscillator (MO) distributes a stabilized 1.3 GHz reference to which the master laser-oscillator (MLO), with a repetition rate of 216.7 MHz (a sixth of the MO frequency), is locked. While this MLO lock still employs a simple homodyne scheme at FLASH, the locking of the MLO at the European XFEL will benefit from a more robust and drift-free approach [1]. The stabilized pulse train from the MLO is split into multiple channels and guided to the individual link stabilization units (LSUs) through the free-space distribution (FSD). Each LSU actively stabilizes the effective length of its assigned optical link fiber, which can be conveniently guided through the entire FEL to stations obliged to femtosecond timing stability.

The optical synchronization supplies 12 stations the stabilization of the RF reference [1], 7 laser-to-laser locking stations (L2L) [2] and 7 stations with direct usage of the pulse train for bunch arrival-time measurement (BAM) [3]. One notable feature in this optical synchronization system is the slave laser-oscillator (SLO) at the end of the FEL. A sub-synchronization will be located in the experimental hall at the end of the beamlines to facilitate all the synchronization needs for the pump-probe lasers on-site. Additionally, it will stabilize all stations between 2.1 km and the end of the experimental hall. Hence, two more links with a length of 3.5 km are provided for SLO to MLO locking. On the one hand this serves as a redundancy improving reliability and robustness. On the other hand these two long links can be cross-correlated in-situ for diagnostics providing numbers for the actual synchronization accuracy. One more LSU is included in this planning to reserve space for later use yielding 24 LSUs in total for the main synchronization.

The latest status of the LSUs deployed at FLASH is described in [4], while a redesigned LSU has been introduced in [5] and is shown in Figure 2.

MEASUREMENTS

Set-up

The set-up for measuring the residual error of the fiber-link stabilization is kept as close as possible to the operation conditions at the European XFEL. A 1.3 GHz signal source is used as the Master-Oscillator (MO) to lock the Laser-Oscillator at its repetition frequency of 216.7 MHz, which is a sixth of the 1.3 GHz. The 200 fs pulses of the MLO centred around an optical wavelength of 1553 nm are distributed to the Link-Stabilization-Unit (LSU) and the out-of-loop (OOL) optical cross-correlator (OXC). The LSU is connected to 3.6 km of polarization maintaining fiber (PMF) with a partly reflecting fiber mirror at its end, which reflects a part of the light back to the LSU for timing detection. The transmitted part is fed into the OOL-OXC for timing error measurement. All components are placed in a climatized laboratory except for the fiber. The fiber is installed in a large hall at the DESY campus next to the laboratory to emulate completely uncontrolled ambient influence. As temperature and humidity do influence optical fibers [6] only such a test environment can guarantee proper test conditions. Identical to the installation in the European XFEL only the 3.6 km PMF is subjected to changes of temperature and humidity. All complementary fibers such as the dispersion compensating fiber, the piezo fiber stretcher, erbium doped fiber amplifier, etc., are left in the climatized laboratory. The deviation between the fiber length of 3.6 km and the European XFEL length of 3.4 km is

* cezary.sydlo@desy.de

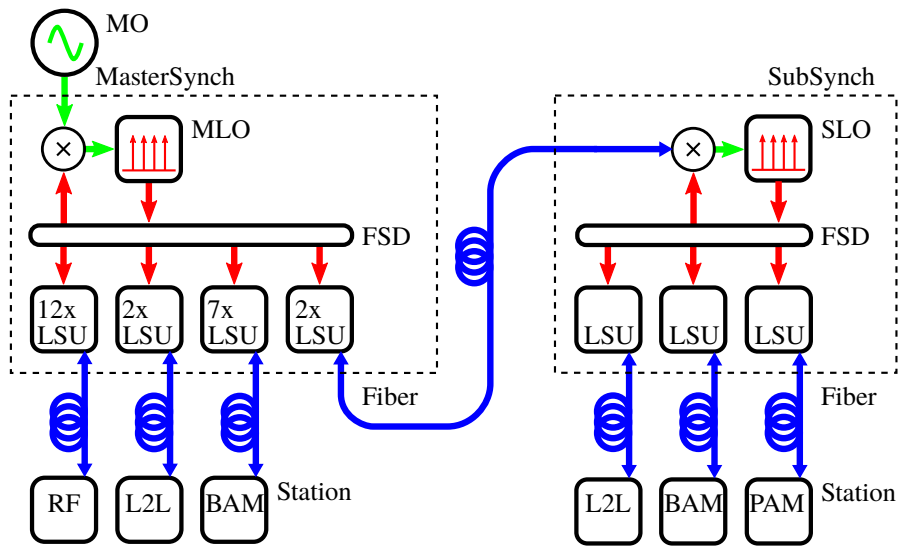

Figure 1: Schematic representation of the optical synchronization system for the European XFEL. The master synchronization will be located close to the injector and stabilize all stations up to 2.1 km. Also the slave laser oscillator of the sub-synchronization will be synchronized in the experimental hall 3.4 km downstream. All the stations between 2.1 km and the experimental hall will be synchronized from there.

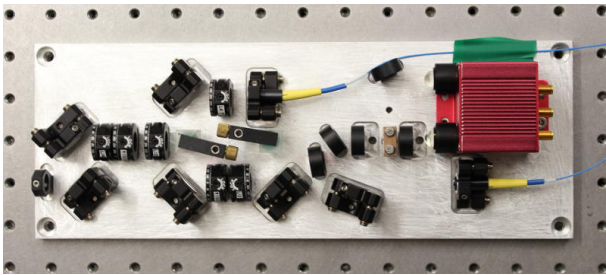

Figure 2: Laboratory prototype of the new Link Stabilization Unit for the European XFEL. This very prototype has been deployed for the stabilization of the 3.6 km link and the corresponding out-of-loop timing error measurements.

chosen to account for the fiber cabling paths. Consequently, the overall fiber length is longer and the response time of the fiber link is about $40 \mu\text{s}$ in total. A schematic of the set-up is depicted in Figure 3.

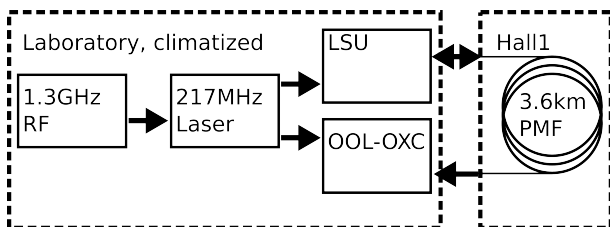

Figure 3: Schematic of the used setup to measure out-of-loop timing error. The Master-Oscillator (MO) delivers a stable 1.3 GHz signal to lock the Master-Laser-Oscillator at a sixth of its frequency. The Link-Stabilization-Unit (LSU) stabilizes the 3.6 km PMF, which is installed in an adjacent hall. The residual error is measured out-of-loop (OOL) with an Optical Cross Correlator (OXC).

Discussion of results

The set-up described before has been aligned, calibrated and measured for about one day. The measurement results are shown in Figure 4. Most noticeable from 25 h of operation is the large jitter of about 15 fs peak-to-peak (Gray color).

The residual drift observed over this time range has been calculated by a convolution of the raw data with a Hanning-window of 1 h full length and is about 8 fs represented by the black colored curve in Figure 4. The standard deviation for the raw data is calculated to 3.3 fs while subtracting the drift it reduces to 2.8 fs.

Especially the work on this drift is quite delicate as these levels of timing error are easily obtained from temperature and humidity dependence of pretty much everything. Table 1 contains temperature and relative humidity coefficients of materials which are commonly used in optics set-ups. These numbers already suggest that even small temperature variations can very easily cause the observed drifts. For this reason an optical table made out of superinvar (compare Table 1) has been installed in the synchronization room of the European XFEL to reduce these effects. However, tests in the laboratory do not benefit from this type of material as standard steel tables are used there. Also, for these lengths of stabilized fibers another effect has been observed. The temperature of the fiber does not only affect its effective length, but also its chromatic dispersion [7]. This effect changes the optical pulse shapes in the OXCs and therefore affects timing detection. Distinguishing between all these temperature effects on the femtosecond level has become a quite tedious task. Nevertheless, this work is ongoing and promises to further enhance the timing stability.

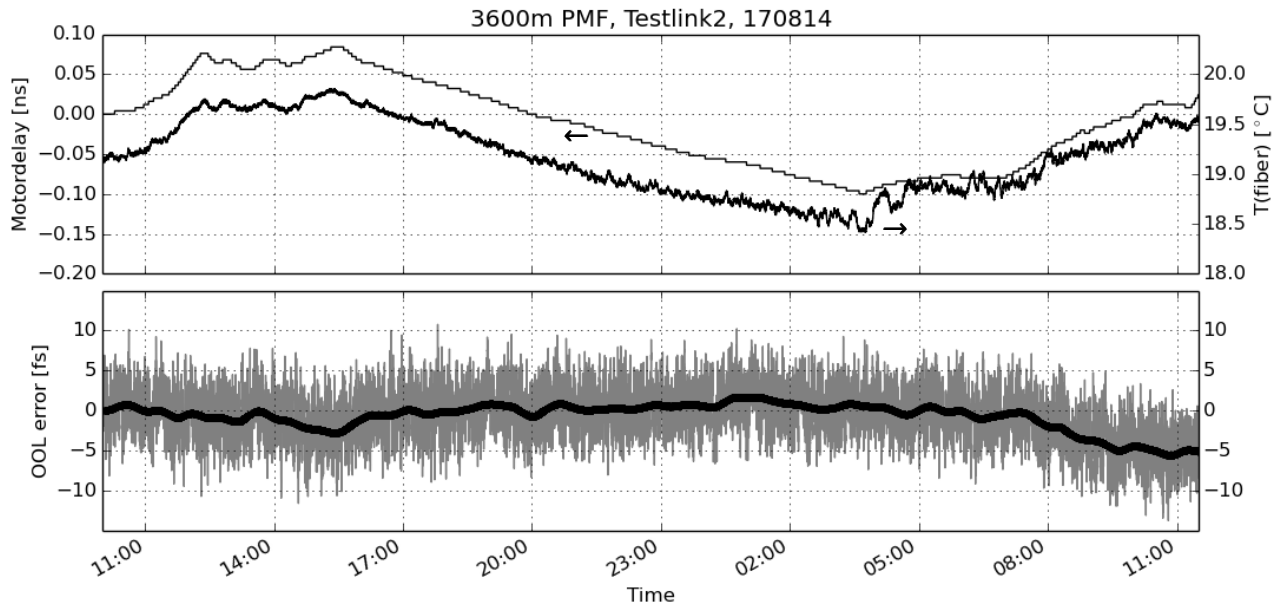

Figure 4: In the top graph the compensated length change of the fiber and the corresponding temperature is shown. The delay is given for one-way and therefore represents the drift of 3.6 km polarization maintaining fiber. The steps in this curve are 1.2 mm or 4 ps for each motor tuning step. The lower graph presents the measured residual out-of-loop timing error at the end of the stabilized fiber. Gray color shows the raw data, while the black line is a convolution with a Hanning-window of 1 h full length to distinguish between jitter and drift.

Table 1: Temperature and humidity influence of various materials

Material	Temperature fs / K / m	Rel. humidity fs / %RH / m
Aluminum	≈ 77	-
Steel [8]	33	-
SMF28e [6]	40	2.5
Furukawa PSOF [6]	3.2	0.4
Air (at 1550nm)	3	0.03
Superinvar [8]	<1	-

CONCLUSION

The results presented in this work are already well in agreement with the synchronization requirements for the European XFEL. We obtained jitter levels of 15 fs peak-to-peak and overall 3.3 fs RMS over 25 h. The design state for the LSUs has already been frozen and is ready for production.

However, for each systematic error there is also a systematic solution. The limits of achievable synchronization errors with reasonable complexity are not reached yet. Further work will concentrate on these limits to be prepared for potentially increased requirements in the future.

REFERENCES

- [1] T. Lamb et al., “Femtosecond Stable Laser-to-RF Phase Detection for Optical Synchronization Systems”, IBIC 2013, Oxford, Sept. 2013, TUPC33, <http://www.JACoW.org>
- [2] S. Schulz et al. “Femtosecond-precision synchronization of the pump-probe optical laser for user experiments at FLASH”, Proc. SPIE 8778, Advances in X-ray Free-Electron Lasers II: Instrumentation, 87780R (May 3, 2013); doi:10.1117/12.2021572
- [3] M.K. Czwalinna et al. “New Design of the 40 GHz Bunch Arrival Time Monitor Using MTCA.4 Electronics at FLASH and for the European XFEL”, IBIC 2013, Oxford, Sept. 2013, WEPC31, <http://www.JACoW.org>
- [4] F. Zummack et al., “Status of the Fiber Link Stabilization Units at FLASH”, IBIC 2013, Oxford, Sept. 2013, MOPC33, <http://www.JACoW.org>
- [5] C. Sydlo et al. “Development Status of Optical Synchronization for the European XFEL”, IBIC 2013, Oxford, Sept. 2013, WEPC31, <http://www.JACoW.org>
- [6] M. Bousonville “Fiber Drift Measurement”, DESY Internal Measurement Protocol, 2011, DESY, Hamburg, Germany
- [7] Hamp et al. “Temperature dependence of chromatic dispersion in optical fiber”, IEEE PHOTONICS TECHNOLOGY LETTERS, VOL. 14, NO. 11, NOVEMBER 2002
- [8] Newport Corporation, <http://www.newport.com>