

POWER SUPPLIES TRANSIENT RECORDERS FOR POST-MORTEM ANALYSIS OF BPM ORBIT DUMPS AT PETRA-III

G. K. Sahoo[#], P. Bartkiewicz, A. Kling, B. Pawlowski
Deutsches Elektronen Synchrotron, DESY, Hamburg, Germany.

Abstract

PETRA-III is a 3rd generation synchrotron light source dedicated to users at 14 beam lines with 30 instruments. The storage ring is presently modified to add 12 beam lines. PETRA III was operated with several filling modes such as 40, 60, 480 and 960 bunches with a total current of 100 mA at electron beam energy of 6 GeV. The horizontal beam emittance is 1 nmrad while a coupling of 1% amounts to a vertical emittance of 10 pmrad. During a user run the Machine Protection System (MPS) may trigger an unscheduled beam dump if transients in the current of magnet power supplies are detected which are above permissible limits. The trigger of MPS stops the ring buffers of the 226 BPM electronics where the last 16384 turns just before the dump are stored. These data and transient recorder data of Magnet Power Supply Controllers are available for a post-mortem analysis. Here we discuss in detail the functionality of a Java GUI used to investigate the transient behavior of the differences between set and readout values of different power supplies to find out the responsible power supply that might have led to emittance growth, fluctuations in orbits or beam dumps seen in a post-mortem analysis.

INTRODUCTION

PETRA-III [1] is a 3rd generation synchrotron light source commissioned with electron beam energy of 6 GeV and 100mA stored current at betatron tune values of 36.12 and 30.28. The horizontal beam emittance is 1 nmrad while a coupling of 1% amounts to a vertical emittance of 10 pmrad. The machine is dedicated to users for experiments from 14 beam lines with 30 end-stations. The storage ring is presently being modified to incorporate 12 new beam lines including a Superlumi beam line from dipole radiation. PETRA operates with several filling modes, such as 40, 60, 480 and 960 bunches with a beam current of 100 mA. During the normal user operation, there are unscheduled beam dumps triggered by the Machine Protection System (MPS) [2, 3]. These triggered dumps may occur before or some times after the loss of beam. The reasons for beam loss due to the MPS are of course understood. But the loss of beam prior to the beam dump by the MPS or a sudden fall of beam current, are unexpected. In these cases the reason remains unidentified or in some cases undetected. However, although the beam is lost, it leaves its signature in its post-mortem data. These post-mortem data are huge and contain a lot of information which can be extracted and analyzed in a Java Web Application MEOC [4]. Here we discuss how the Power Supply Controller (PSC)

Transient Recorders are used in the post-mortem analysis to pin point the source of disturbance in magnet power supplies.

TECHNICAL OVERVIEW

All PETRA III magnets are driven by power supplies designed and manufactured at DESY (Fig. 1), controlled by intelligent PSCs [5].



Figure 1: PETRA-III power supply modules.

The PSC design is based on generic controller mezzanine boards (Fig. 2), designed also at DESY and widely used for other control purposes as well. The board consists of Freescale Coldfire (MCF5282) microcontroller and Altera FPGA (Flex EPF10K50), offering not only control and communication capabilities, but also enough resources needed for real time output current monitoring and transient recording.

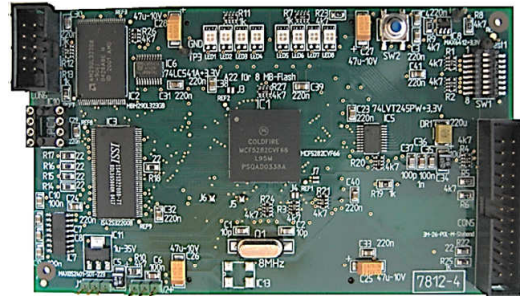

Figure 2: Generic Freescale Coldfire MCF 5282 based mezzanine card widely used for control purposes.

The 614 PSCs communicate over CAN buses (CANopen protocol [6]) with 20 front-end servers, running on PC104 Fanless Industrial Computers [7] with an embedded Linux operating system. The TINE [8, 9] network environment integrates the front-end servers with the PETRA-III control system and provides them access to central services, like data archiving, alarms and events recording systems (Fig. 3).

[#] Gajendra.Kumar.Sahoo@desy.de

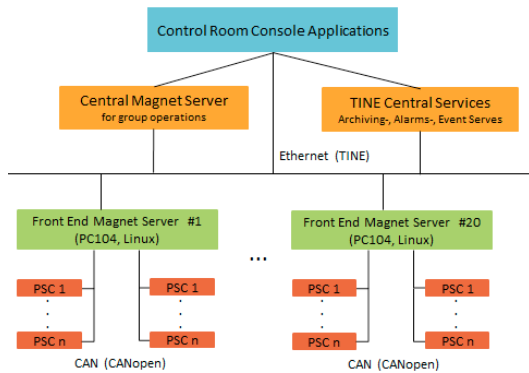

Figure 3: Schematic structural view of PETRA III magnet control system.

During a PETRA user run the circular buffer of length 20160, of which 16-bit words is filled every 500 microseconds with an averaged value of the difference between current set point and the measured current read back value. The number of samples used for averaging can be defined in range of 2 to 255. If the absolute value of the averaged difference is bigger than a configured threshold, the trigger is recorded. The local controller time is stored along with the trigger position, as well as the controller status bits. It is important that the local time of the PSC is synchronized with the front-end server time using the Time-stamp CANopen protocol, and the front-end server's time is synchronized with the global DESY control system time by TINE services. The trigger position within the circular buffer can be freely defined, making possible focusing on the recordings just before or just after the trigger. Since the transient recorder is designed to monitor transitions during a stable run and not during the machine energy ramp, the trigger is automatically disabled by the PSC while performing the change of power supply current. Additional parameters provide information about the trigger system activation, such as a time-delay following a ramp, in order to reject possible current fluctuations due to the magnet inductance.

At present all transient recorder parameters are set individually for each PSC using a dedicated client application. More sophisticated configuration tools, performing quick and convenient PSC group's configuration, are planned.

The front-end servers monitor periodically the status of all PSCs. For each triggered recorder the circular buffer content is transferred via the CAN bus to the server's memory and a Transient Recorder Event is sent to the TINE Event Server. In response to the event reception the Event Server fetches all copies of transient recorders buffers from the front-end servers and makes them available in the Archive System, where client applications can find them for further analysis.

GUI PSC TRANSIENT RECORDER

The Java GUI PSC Transient Recorder as shown in Fig. 4 is one of features in its main panels. The other panels are used to show the difference in set and read

back values, fast Fourier transforms, the Gaussian distribution, the Change of Events, as well as the Standard Out and Standard Error. There are provisions of choosing all PSCs, a particular type, or a particular PSC. The table shows the information associated with the PSC.

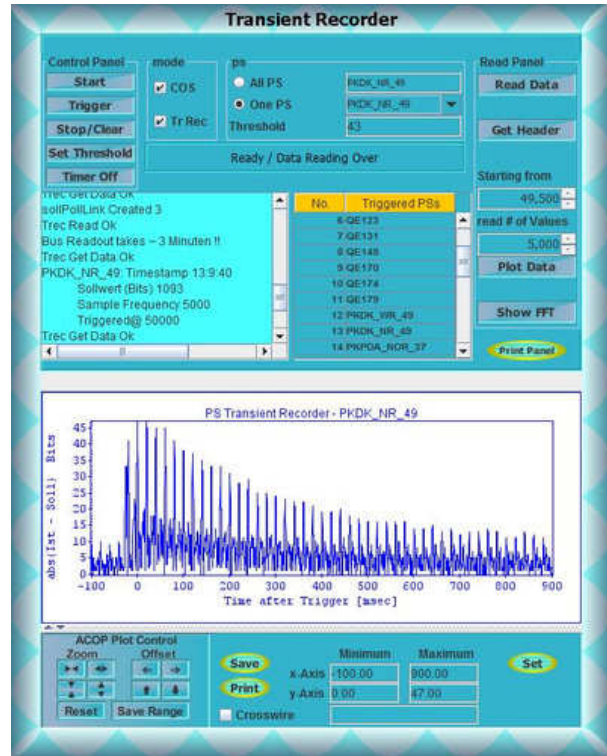

Figure 4: The graphics user interface of PSC Transient Recorder.

RESULTS AND DISCUSSIONS

Wrong Setting of Corrector Magnets

The orbit is corrected using slow orbit correction [10] based on the SVD algorithm employing 191 horizontal correctors, 187 vertical correctors and 226 BPMs. During normal user operation the golden orbit is maintained with additional 40 fast correctors on either plane using same algorithm. During the process of correction some correctors may set higher currents than desire leading to high orbit oscillations. This can also happen due to spikes in fast or slow corrector magnets. A small change in set current of any PS can be treated as the effect of an artificial corrector incorporated in it. So, in case of unknown beam dumps, the change in orbits in post-mortem data may be corrected choosing a few numbers of correctors. The MEOC is utilized to investigate the suitable corrector that might have perturbed the orbit beyond the interlock limits. For example, the event (Fri Mar 15 11:02:17 CET 2013) was due to the failure of the vertical corrector magnet PKVSU_SWL_46 which was receiving wrong set values due to spikes leading finally to a beam dump. You can see from Fig. 5 that the difference orbit was well corrected to zero using the same corrector.

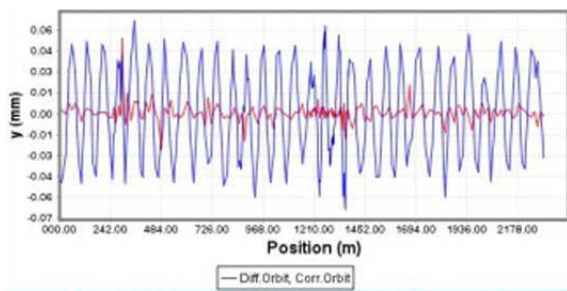

Figure 5: Vertical orbit correction for the Interlock Event on Friday 15 March 2013 at 11:02:17 which indicates that PKVSU_SWL_46 vertical corrector as the source of orbit perturbation.

Regulation Problems in PKVSX & PKVSU

There are 18 PKPDA type horizontal corrector magnets available as the back-leg windings in PDA type dipole magnets in the new DBA octant. These PSs are mostly trigger events in PSC Transient Recorders as the current controls in these are not good enough. Similarly, there are extra windings in sextupole magnets of S1, S3 and SDU to generate vertical correction coils. These coils are known as PKVSX (for S1, S3) and PKVSU (for SDU) type corrector magnet with a maximum of 55A, on 0.114mA/bit with a threshold of 240bits. But in operation many of these correctors are powered at less than 10A at which the controls do not work properly. Thus many of these PSs are frequently triggered in PSC Transient Recorders

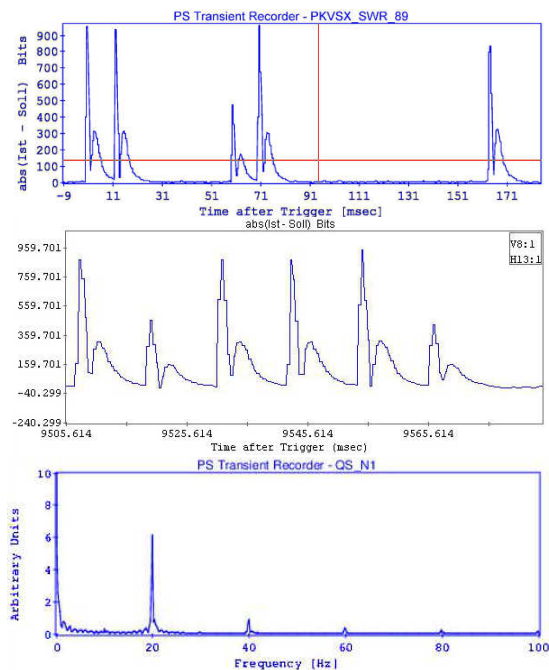

Figure 6: (a) The transients in the PS PKVSX_SWR_89, (b) The transients in the PS PKVSU_SWL_46 recorded in Transient recorders where the difference in between set & read back current is ~1000bits and (c) shows the frequency spectrum of the transients in PS QS_N1.

It is also noticed that the PSC associated with the quadrupole magnet Q4K_R is very often triggered. Some of the observations are shown in Figure 6 where the transients are much above the threshold limits of the respective power supplies.

CONCLUSION

The present PSC Transient Recorder is utilized to monitor the transients in 614 PSs of PETRA III electron storage ring. All the PSs are manually put in active mode which are triggered when the difference in read and set values are larger than the thresholds of respective PSCs. This is used with post-mortem analysis of BPM beam dumps to find the responsible PS that disturbs stability or causes loss of beam. We are currently developing auto triggers which would utilize circular buffers in the continuous monitoring of PSC transients in order to improve stability and reliability of PETRA III operation.

ACKNOWLEDEMENTS

The authors gratefully acknowledge and would like to thank for the initial contributions by Steve Herb; and Rainer Wanzenberg and Reinhard Bacher for their constant encouragements and guidance.

REFERENCES

- [1] K. Balewski, W. Brefeld, et al., "PETRA III: A new high brilliance synchrotron radiation source at DESY", EPAC-2004, Lucerne, 2004, pp.2302-2304.
- [2] T. Lensch, M. Werner, "Machine Protection System for PETRA III", Proceedings of DIPAC09, Basel, Switzerland, pp 351-353, 2009.
- [3] http://ttfinfo.desy.de/petra/show.jsp?dir=/2011/17/29.04_a&pos=2011-04-29T15:26:23
- [4] G.K. Sahoo, K. Balewski, A. Kling, "Post-Mortem Analysis of BPM-Interlock Triggered Beam Dumps at PETRA-III", PCaPAC 2012, Kolkatta, pp 43-45.
- [5] B. Pawlowski, private communication.
- [6] <http://www.can-cia.org/index.php?id=canopen>
- [7] http://www.pc104.org/pc104_specs.php
- [8] P.K.Bartkiewicz, P. Duval "TINE as an accelerator control system at DESY", Measurement Science And Technology, 18 (2007) pp 2379-2386
- [9] <http://tine.desy.de>
- [10] G.K. Sahoo, K. Balewski, et al., "Closed orbit correction and orbit stabilization scheme for the 6 GeV synchrotron light source PETRA III", EPAC-2004, Lucerne, 2004, pp.2302-2304.