

HIGHER ORDER MODE COUPLERS FOR NORMAL CONDUCTING DORIS 5-CELL CAVITIES

B. Dwersteg, E. Seesselberg, A. Zolfaghari
 Deutsches Elektronen-Synchrotron DESY
 Notkestrasse 85
 D-2000 Hamburg 52, W. Germany

Abstract

The beam intensity of the DORIS e^+e^- storage ring is limited to about 100 mA average circulation current as a result of instabilities driven by higher order rf cavity modes. Thus an investigation has been made of the higher order mode impedances of the DORIS rf accelerator cavities. These cavities are the same as the normally conducting inductively coupled 500 MHz 5-cell structures used in PETRA. The results of the investigation were applied for the construction of inductive and capacitive attenuation antennae corresponding to specific mode spectra and mode impedances. The antennae must fit into the existing 35 mm pick up flanges of the cavities and in spite of these size and position limitations they must be efficient in reducing the shunt impedances of the dangerous modes.

Introduction

Originally the DORIS e^+e^- storage ring was equipped with single cell cavities. Operation at 2.5 GeV with beam intensities up to 500 mA was made possible by providing the cavities with mode damping antennas.¹ To increase the DORIS energy to 5.6 GeV the single cell cavities were replaced by PETRA 5-cell 500 MHz cavities. The maximum beam intensity with these cavities is about 100 mA circulating current. The limitation is given by Higher Order Mode (HOM) resonances excited by the particle beam and superimposed to the fundamental mode accelerating field. HOM's can cause beam instabilities if their frequency coincides with a spectral line of the beam rf spectrum and if at the same time HOM shunt impedance RS is high enough. This impedance is defined in the same way as the fundamental mode shunt impedance:

$$RS = U_{\text{HOM}}^2 / 2 P_{\text{HOM}}$$

Reducing the impedances of the dangerous HOM's will shift the DORIS intensity limitation to higher values.

Short Description of the DORIS Cavity

The DORIS cavity shown in Fig. 1 is the same as the PETRA 5-cell structure.² The fundamental mode shunt impedance is 18 M Ω . Test power level is up to 200 kW. Continuous operation power is possible up to 125 kW (Fig. 1).

The pick up flanges are the only possibility of inserting mode damping elements without occupying the pumping flanges. Pick up openings of only 35 mm and given angular and axial positions (Fig. 1) are limitations for the effectivity of mode damping. The small size allows neither an integrated antenna absorber system¹ nor big antennas. It is not possible to optimize the antenna positions in order to couple to the highest field of HOM's. An impedance reduction by a factor two or three for the most dangerous modes seems already a reasonable first goal since currents higher than 400 or 500 mA may already overheat some components of the DORIS vacuum system.

HOM-Investigation

The first HOM investigation step was done by application of a computer program URMEI³ to the 5-cell cavity geometry. More than 100 resonance modes were found by this computation in the range between 500 and 1900 MHz.

The inductive coupling slots of the structure could not be taken into the computation. Nevertheless the main results showed reasonable agreement with reality: The modes with the highest computed impedances showed the highest measured impedances too. Maximum frequency differences between computation and measurement were 30 MHz.

Table 1 shows a comparison of computations against measurements of the most dangerous HOM's.

Tab. 1

Frequency [MHz]		Type	Shunt Impedance [k Ω /m]	
Compu- tation	Measure- ment		Compu- tation	Measure- ment
756.2	730.1	TM011	2330	406
756.3	730.7	TM011	935	53
852.3	831.7	TM110	4100	455
853.1	834.1	TM110	1350	69
1021	1010.2	TM111	8340	89

The differences between impedance values can be explained by the fact, that the real cavity is not rotation symmetrical and doesn't have equal cells as assumed in the computation and its Quality Factor is lower than theoretical value.

Fig. 1

PETRA ACCELERATION
 STRUCTURE
 USED IN DORIS

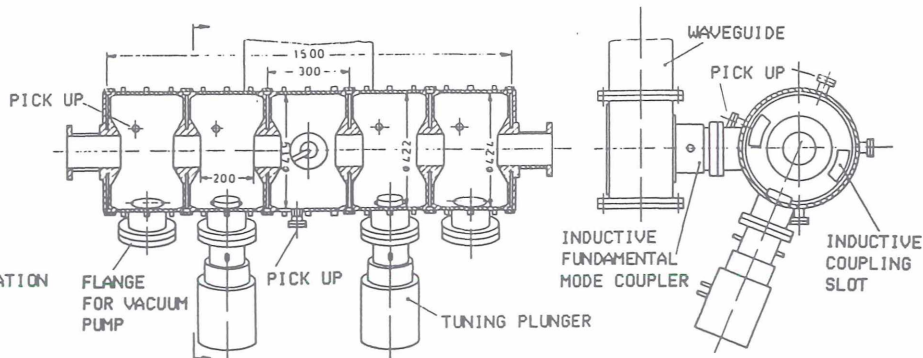

The TM 011 mode is rotation symmetrical. TM 110 and TM 111 are Dipole Modes.

HOM angular positions and energy distributions are very important data obtained from beadpull field measurements. Angle and field amplitude distribution over the cells are deciding factors to determine whether to insert a capacitive or an inductive antenna. TM 110 and TM 111 impedances are defined 5 cm off axis because they have no axial fields in the cavity. Measurements showed too, that cavity tuning with the plungers doesn't change the HOM frequencies more than the fundamental mode frequency. Mode positions and distributions are not influenced.

Design of HOM Couplers

Capacitive and inductive HOM antennas at several cells are required as a consequence of the HOM investigation results. To couple a maximum of mode power to external loads the antennas should be large and they should reach deep into the cavity fields. The fundamental mode coupling has to be prevented as much as possible. An additional fundamental mode power dissipation of 10 W per cm² of antenna surface cannot be avoided at a 200 kW cavity operation power level. This requires sufficient fundamental mode filtering and cooling.

Inductive HOM Coupler

For the inductive antenna shown in Fig. 2 a loop of 5 cm² was chosen. This would lead to a fundamental mode coupling of $\beta = 6$ if no stopband filter was installed. Therefore a $\lambda/4$ filter was integrated as a series circuit in a double coaxial construction. The surface power at the loop was expected to be 150 W. The filter loss was computed to be 500 W of fundamental mode power. The maximum voltage across the capacitive filter gap of 3.5 mm is 7 kV. Filter attenuation should be greater than 40 dB. The loop consists of a 4 mm diameters double tube. A second water circuit cools the inductive parts of the filter. Without water cooling the coupling loop would melt and all parts of the filter would be overheated. The expected temperatures here are lower than 130° C.

Inductive coupling is necessary for the TM 110, which cannot be capacitively coupled. Consequently the total inductive coupler including elements like the ceramic window is designed to form a broadband filter overcoupling especially the 830 MHz band, while still being effective up to 1500 MHz. Fig. 4 shows the inductive coupler design.

Capacitive HOM Coupler

Theoretically a capacitive HOM coupler inserted in the pick ups opening cannot couple fundamental mode, but in practice the antenna of the capacitive coupler shown in Fig. 3 coupled - 27 dB of fundamental

mode power. This high value is reduced by an antenna construction with a nose to compensate assymetries of the fundamental mode field (Fig. 5).

A compensated antenna allows to tune fundamental mode coupling to practically zero without a filter by simply rotating it in the pick up flange. Zero coupling is equivalent to no fundamental mode losses in the coupler. Only surface losses of 100 W have to be cooled away from the end of the capacitive coupler. A coaxial stub was used to cool the inner conductor with water. Capacitive coupling is obvious for the TM 011 and TM 111. These modes have their maximum radial electric surface field in the middle of the cells near pick up position. The coupler was designed to have a flat band filter characteristic with impedance maxima at 730 MHz and 1010 MHz to couple both modes as strongly as possible. The capacitive coupler is shown in Fig. 5.

Measurements and High Power Test

The impedance of each mode of Table 1 can be reduced by a factor of 3 with a single coupler mounted to a cavity.

A successful power test in a DORIS cavity with both coupler types was made with up to 110 kW of fundamental mode power. The fundamental mode coupling to the external loads was - 55 dB for the inductive HOM coupler and - 65 dB for the capacitive HOM coupler.

The calorimetrically measured power losses were: 640 W in the band stop filter and 200 W in the loop of the inductive coupler, 90 W in the antenna of the capacitive filter.

A measurement at 40 kW cavity power in a detuned cavity showed that detuning has no effect on capacitive antenna coupling. The inductive antenna changes the fundamental mode coupling to a value of - 45 dB with 0.3 cavity MHz detuning and to - 35 dB at 1 MHz detuning.

The power test showed also that the center frequency of the stop band filter is power dependent, e.g., a 100 kW change in cavity power lowers the center frequency by more than 1 MHz. An evaluation of this value yields 100 W of filter capacity power loss for the inner conduction cooled conductor. This corresponds to the expected 130° C temperature at the cavity end of that filter component. Because of this power dependence it is reasonable to tune the filter center frequency to 1 MHz over the cavity resonance frequency. This will guarantee a minimum fundamental mode outcoupling at the maximum cavity power.

Conclusions

A theoretical analysis⁴ of the HOM investigation results shows that the TM 110 is especially likely to cause a strong transverse instability. The DORIS beam intensity is expected to increase proportionally to the HOM impedance reduction. An inductive and a capa-

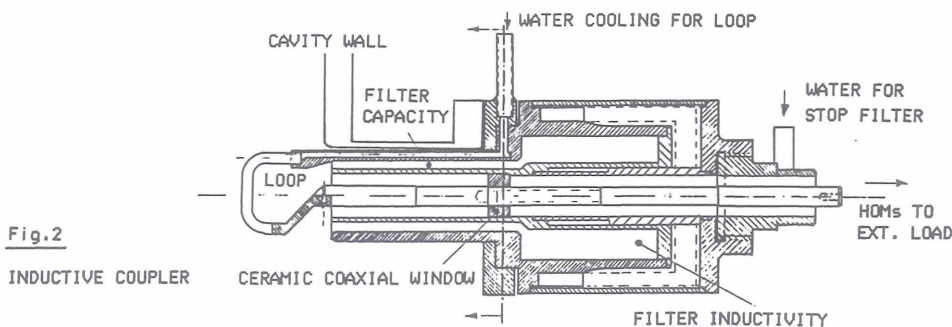

Fig.2
INDUCTIVE COUPLER

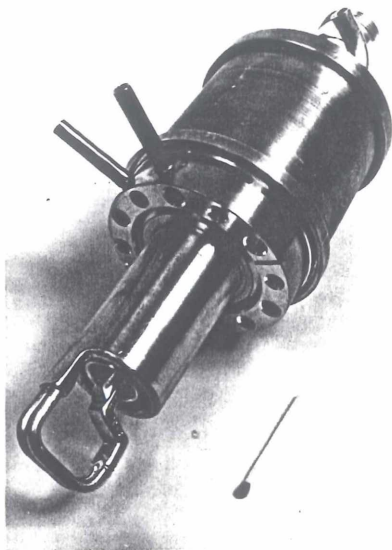
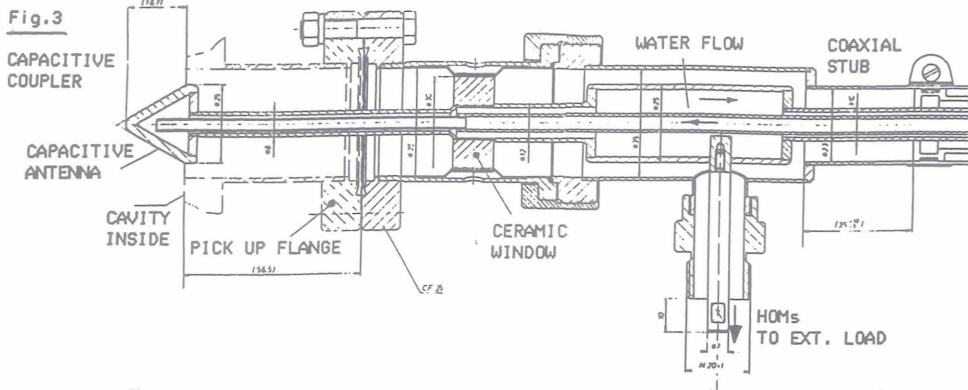

Fig. 4
Inductive coupler

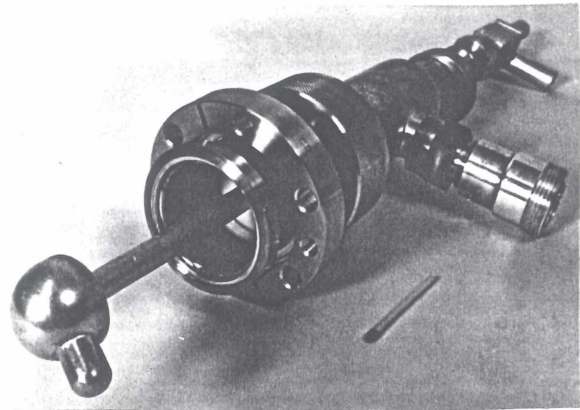

Fig. 5 Capacitive coupler

capacitive coupler have been built to attenuate the modes. They were successfully power tested up to 110 kW fundamental mode power in a DORIS cavity. Measurements with single couplers showed a minimum impedance reduction factor of 3 for the dangerous modes. It is planned to provide every DORIS cavity with 2 capacitive and 2 inductive couplers during the winter shut down 1985/86. The maximum mode power per cavity can be estimated very roughly to be 10 kW for a DORIS beam current of 200 mA. An impedance reduction factor of 5 and full excitement of at least one HOM are assumed.

Experience with superconducting cavities in PETRA showed always less actual mode power than predicted.

Some slight changes concerning filter tuning and cooling, especially of the inductive coupler, will be made before series production of both coupler types.

References

- [1] N. Lehnart and H. Petersen, "Damping Antennas for Spurious RF-Modes in Electron-Positron Storage Rings", in Nuclear Instruments and Methods 153, pp.51-52, 1978
- [2] H. Gerke, H.P. Scholz, M. Sommerfeld, A. Zolfaghari, "Das PETRA Cavity", DESY PET-77/08
- [3] T. Weiland, "URMEL User Guide", DESY M-82-24
- [4] R.D. Kohaupt, DESY, private communication